

**PRELIMINARY STORMWATER POLLUTION
PREVENTION PLAN (SWPPP)**

WATKINS GLEN SOLAR ENERGY CENTER

**TOWN OF DIX
SCHUYLER COUNTY, NEW YORK**

**IN COMPLIANCE WITH THE
NEW YORK STATE DEPARTMENT OF ENVIRONMENTAL
CONSERVATION GENERAL PERMIT GP-0-20-001
FOR
STORMWATER DISCHARGES FROM CONSTRUCTION ACTIVITIES**

Prepared for:

Watkins Glen Solar Energy Center, LLC
700 Universe Boulevard
Juno Beach, FL 33408

Prepared by:

TRC
215 Greenfield Parkway, Suite 102
Liverpool, NY 13090



September 2020

Table of Contents:

1.0	Introduction	1
2.0	Regulatory Requirements	1
3.0	Permit Coverage Information	2
4.0	SWPPP Amendments	2
5.0	Project Information	4
5.1	Soils Classification	4
6.0	Contract Documents	5
7.0	Personnel Contact List	5
8.0	SWPPP Construction Requirements and Sequencing	6
9.0	Stormwater Management and Pollution Controls	8
9.1	Potential Impacts for Stormwater Contamination.....	9
9.2	Protection of Existing Vegetation	10
9.3	Temporary Erosion and Sediment Controls.....	10
9.3.1	Temporary Stockpiling	12
9.3.2	Temporary Spoil Stockpiling	12
9.3.3	Construction Access Systems	13
9.3.4	HDD	13
9.4	Temporary Stabilization for Frozen Conditions.....	14
10.0	Construction Pollution Prevention	15
10.1	Management of Spills and Releases	15
10.2	Construction Housekeeping.....	16
10.2.1	Material Stockpiling.....	16
10.2.2	Staging, Storage, and Marshalling Areas	16
10.2.3	Equipment Cleaning and Maintenance	17
10.2.4	Concrete Washout Areas.....	18
10.3	Waste Management.....	18
11.0	Maintenance Inspections and Reporting Requirements	19
11.1	Pre-Construction Inspection.....	19
11.2	Construction Phase Inspections	19
11.3	Temporary Construction Activity Suspension	20
11.4	Partial Project Completion	20
11.5	Reporting Requirements	21
11.6	Post-Construction Record Archiving	21

List of Tables:

Table 1 - Proposed Erosion and Sediment Control Measures.....	11
---	----

Appendices:

Appendix A – SWPPP Permit Coverage Forms

- Notice of Intent (NOI)
- SWPPP Preparer Certification Form
- Owner/Operator Certification Form
- NYSDEC NOI Acknowledgement Letter for Permit Coverage
- Notice of Termination (NOT) Form

Appendix B – General Permit GP-0-20-001

Appendix C – Construction Personnel Contact List

- Construction Contact List
- Contractor Certification Form

Appendix D – Agency Correspondence and Notifications

- NYSDEC Solar Panel Construction Stormwater Permitting/SWPPP Guidance Memorandum
- Maryland Department of the Environments (MDEP) Stormwater Design Guidance – Solar Panel Installation

Appendix E – Environmental Background Information

- Environmental and Cultural Resource Information
- USDA NRCS Soil Resource Report

Appendix F – Preliminary Design Drawings

Appendix G – Standards and Specifications for Erosion and Sediment Controls

Appendix H – Spill Cleanup and Reporting Guidance

- NYSDEC Technical Field Guidance: Spill Reporting and Initial Notification Requirements
- NYSDEC CP-51: Soil Cleanup Guidance

Appendix I – SWPPP Amendments

Appendix J – SWPPP Inspection Reports

- Blank SWPPP Inspection Form
- Completed SWPPP Inspection Reports

1.0 Introduction

This Preliminary Stormwater Pollution Prevention Plan (SWPPP) has been prepared by TRC for Watkins Glen Solar Energy Center, LLC (the Client) in regard to construction activities associated with the Watkins Glen Solar Energy Center (the Project). The purpose of this SWPPP is to establish requirements and instructions for the management of construction-related stormwater discharges from the Project Area. Erosion and sediment controls have been designed and shall be installed and maintained to minimize the discharge of pollutants and prevent a violation of the water quality standards.

2.0 Regulatory Requirements

This SWPPP has been prepared in accordance with the “New York State Department of Environmental Conservation (NYSDEC) State Pollution Discharge Elimination System (SPDES) General Permit for Stormwater Discharges from Construction Activity” General Permit GP-0-20-001, effective January 29, 2020 through January 28, 2025. The NYSDEC requires coverage under GP-0-20-001 for any “construction activities involving soil disturbances of one or more acres; including disturbances of less than one acre that are part of a larger common plan of development or sale that will ultimately disturb one or more acres of land; excluding routine maintenance activity that is performed to maintain the original line and grade, hydraulic capacity or original purpose of a facility.”

The Project has also been prepared in accordance with the applicable design requirements of the Maryland Department of the Environment (MDEP) Stormwater Design Guidance – Solar Panel Installations and the NYSDEC Solar Panel Construction Stormwater Permitting/SWPPP Guidance Memorandum as required by the stipulations for the Article 10 Application. The Project has been designed to maintain the natural hydrology of the site, to the maximum extent practicable.

The Project is classified as a commercial-scale solar project. The Project involves construction activities that require the preparation of a SWPPP that only includes erosion and sediment control practices designed in conformance with Part III.B.1 of the permit. A copy of the General Permit GP-0-20-001 is provided in Appendix B of this SWPPP.

The Project shall comply with all applicable local, state, and federal regulations to the maximum extent practicable. The Project is subject to Article 10 of the Public Service Law, as Case No. 17-F-0595. This Preliminary SWPPP is included as Appendix 23-3 of the Project's Article 10 Application. The Project also requires a Water Quality Certification Section 401 of the Clean Water Act (CWA).

3.0 Permit Coverage Information

This SWPPP serves as the minimum requirements necessary to address soil exposure and stormwater management during construction activities. This SWPPP is a living document that may be amended for unforeseen circumstances. If unanticipated site conditions warrant changes or additions to existing practices, the Owner/Operator and the Contractor(s), in consultation with the Qualified Inspector or Project Engineer, will be required to implement those measures in accordance with the New York State Standards and Specifications for Erosion and Sediment Control (SSESC) and amendments to the SWPPP shall be made as appropriate. The SWPPP and associated documentation must be kept current to ensure the erosion and sediment control practices are accurately documented.

In accordance with GP-0-20-001, documented site inspections will be performed to ensure the required erosion and sediment control measures have been installed properly and are in good condition. Inspections will occur for the duration of construction, until earth-disturbing construction activities have ceased, and final stabilization has been achieved.

4.0 SWPPP Amendments

This SWPPP has been prepared in accordance with the General Permit and the SSESC. The SWPPP and associated documents must be kept current at all times. Amendments to the SWPPP and associated documents should be made:

- Whenever the current provisions are ineffective in minimizing impacts to the stormwater discharge from the Project Area;
- Whenever there is a change in design or construction activities and sequencing that has or could have an impact to the stormwater discharge; and

- To address deficiencies or issues identified during monitoring and inspection.

This Preliminary SWPPP will be amended to include site-specific post-construction stormwater practices for Final SWPPP. The Final SWPPP will detail the proposed post-construction stormwater practices which will be utilized to treat and control runoff from the Project per the requirements of the General Permit. The post-construction stormwater control practices will provide water quality volume treatment, runoff reduction, and will control the volume and rate of the stormwater runoff. The stormwater design will utilize green infrastructure practices such as reduction in clearing and grading, utilizing open spaces, and locating development in less sensitive areas to the maximum extent practicable. Anticipated stormwater practices may include vegetated swales and level spreaders. The proposed post-construction stormwater practices will be designed in accordance with the requirements of the General Permit, the SDESC, and the New York State Stormwater Management Design Manual.

In addition to the requirements of the General Permit, the Final SWPPP will be designed to include non-rooftop disconnection alternatives in accordance with the MDEP Stormwater Design Guidance – Solar Panel Installation and the NYSDEC Solar Panel Construction Stormwater Permitting/SWPPP Guidance Memorandum. The non-rooftop disconnection for the Project considers the following factors:

- The vegetated area receiving runoff must be equal to or greater in length than the disconnected surface (e.g., width of the row of solar panels);
- Runoff must sheet flow onto and across vegetated areas to maintain the disconnection;
- Disconnections should be located on gradual slopes ($\leq 5\%$) to maintain sheet flow. Level spreaders, terraces, or berms may be used to maintain sheet flow if the average slope is steeper than 5%. For slopes greater than 10%, an engineered plan will be developed to ensure adequate treatment of disconnected runoff and non-erosive runoff conditions;
- Construction vehicles and equipment should avoid areas used for disconnection during installation of the solar panels to avoid soil disturbance and compaction; and
- Groundcover vegetation in areas receiving disconnected runoff must be maintained in good condition.

The Final SWPPP will be amended to include all proposed post-construction stormwater practices and will be included as part of the Compliance Filing. Refer to GP-0-20-001 for additional

information on SWPPP amendment procedures and requirements. Amendments to the SWPPP shall be documented in Appendix I.

5.0 Project Information

The Project Area is located in the Town of Dix, Schulyer County, New York. The Project Area is located within the NYSDEC Region 8 jurisdiction and the Beaver Dams United States Geological Survey (USGS) 7.5 Minute Topographic Quadrangle. Refer to Appendix E for additional Project Area information.

The Project proposes the installation of an approximate 50-megawatt solar array and associated electrical infrastructure, access roads, and security features. The general scope of work for the Project may result in soil disturbance including but not limited to site clearing, grading, horizontal directional drilling (HDD), and installation of the electric utility infrastructure, access roads, and erosion and sediment controls.

The Project Area consists of approximately 771 acres, of which, approximately 392 acres of soil disturbance are anticipated. The existing groundcover of the Project Area is composed primarily of agricultural lands and forested lands surrounded by rural residential areas. The site topography ranges from relatively flat to moderately sloped. Refer to the Preliminary Design Drawings in Appendix F as well as Appendix E for additional Project Area land cover, environmental resource, and topographic information.

The Project Area discharges to Townsend Creek, a NYSDEC Class C stream, and various isolated ponds and wetland areas. The Project Area does not discharge to a 303(d) waterbody segment.

5.1 Soils Classification

Review of the United States Department of Agriculture's (USDA) Natural Resources Conservation Service (NRCS) Web Soil Survey indicated the predominant soil series mapped within the Project Area are Fremont silt loam, Hydrologic Soil Group (HSG) rating D; Lordstown channery silty loam, HSG rating C; Mardin channery silt loam, HSG rating D; Valois

gravelly silt loam, HSG rating B; and Volusia channery silt loam, HSG rating D. The Soil Conservation Service defines the HSGs as follows:

- Type A Soils: Soils having a high infiltration rate (low runoff potential).
- Type B Soils: Soils having a moderate infiltration rate.
- Type C Soils: Soils having a slow infiltration rate.
- Type D Soils: Soils having a very slow infiltration rate (high runoff potential).

For soils assigned to a dual hydrologic group, the first letter refers to drained areas and the second refers to undrained areas. In project areas of unknown soil type or areas not within agricultural land, the more conservative soil classification is assumed.

Refer to Appendix E for the USDA NRCS Soil Resource Report for the Project Area.

6.0 Contract Documents

The Contractor is responsible for the implementation of this SWPPP, as well as the installation, construction, repair, replacement, inspection and maintenance of erosion and sediment control practices. Each Contractor shall sign the Contractor Certification Form provided in Appendix C prior to the commencement of construction activities.

This SWPPP and associated documentation, including but not limited to, a copy of the GP-0-20-001, NOI, NYSDEC NOI Acknowledgement Letter, Contractor Certification Form, Preliminary Design Drawings, inspection reports, and permit eligibility forms, must be maintained in a secure location for the duration of the Project.

7.0 Personnel Contact List

The Construction Personnel Contact List for the Project is provided in Appendix C. The listed personnel are responsible for ensuring compliance with the SWPPP and associated permit conditions. Personnel responsibilities include, but are not limited to, the following:

- Implement the SWPPP;

- Oversee maintenance practices identified in the SWPPP;
- Conduct or provide for inspection and monitoring activities;
- Identify potential erosion, sedimentation, and pollutant sources during construction and ensure issues are addressed appropriately and in a timely manner;
- Identify necessary amendments to the SWPPP and ensure proper implementation; and,
- Document activities associated with the implementation of this SWPPP and supporting documents.

Refer to GP-0-20-001 for information regarding specific personnel responsibilities.

8.0 SWPPP Construction Requirements and Sequencing

This section provides the Owner/Operator and the Contractor with a suggested order of construction that will minimize erosion and the transport of sediments. The individual objectives of the construction techniques described herein shall be considered an integral component of the Project design. The construction sequence is not intended to prescribe definitive construction methods and should not be interpreted as a construction specification document.

The Contractor shall follow the general principles outlined below throughout the construction phase:

- Protect and maintain existing vegetation wherever possible;
- Minimize the area of disturbance;
- To the extent possible, route unpolluted flows around disturbed areas;
- Install approved erosion and sediment control devices as early as possible;
- Minimize the time disturbed areas are left un-stabilized; and,
- Maintain erosion and sediment control devices in proper condition.

The Contractor should use the suggested construction sequence and techniques as a general guide and modify the suggested methods and procedures as required to best suit seasonal and

site-specific physical constraints for the purpose of minimizing the environmental impact due to construction.

The Project is anticipated to involve three stages of work; site preparation, construction, and site restoration. Prior to the commencement of construction activities, temporary erosion and sediment control measures shall be installed per the Preliminary Design Drawings provided in Appendix F. The Project stages are detailed below.

Stage 1: Project Area Preparation

- Establish access to the Project Area including the stabilized construction entrances and access roads;
- Stake/flag construction limits, staging/storage areas, concrete washout locations, environmentally sensitive areas, and other associated work areas;
- Mark existing utilities and infrastructure;
- Conduct tree clearing and vegetation management, if necessary, and grading of work areas, as required; and,
- Install the erosion and sediment controls as detailed on the Erosion and Sediment Control Plans.

Stage 2: Construction

- Perform grading operations as needed;
- Installation of solar array mounting posts;
- Construction of the collection substation;
- Solar panel placement and setting;
- Installation of underground (and, if required, overhead) collection lines for connecting the solar arrays to the Project collection substation; and,
- Installation of any Project Area fencing and security measures.

Stage 3: Project Area Restoration

- Remove and dispose of Project related waste material at an approved disposal facility;
- Prepare soils as needed (restoration of original grade, de-compaction, soil amendments, etc.), and seed and mulching all disturbed areas. Restore disturbed soils per NYSDEC standards and specifications;
- Remove the temporary erosion and sediment controls when 80% of natural vegetative cover has been achieved and erosion issues are no longer present;
- Submit the NOT to the NYSDEC in accordance with the General Permit.

9.0 Stormwater Management and Pollution Controls

Prior to the commencement of construction activities, temporary erosion and sediment controls shall be installed to prevent erosion of the soils and prevent water quality degradation in wetlands and waterbodies. Erosion and sediment controls will be utilized to limit, control, and mitigate construction related impacts. The stormwater management and pollution controls shall include practices that involve runoff control, soil stabilization practices, and sediment control.

The erosion and sediment controls utilized at the Project Area must be installed and maintained in accordance with GP-0-20-001 and the SDESC. Improper installation of practices may result in an increase in water quality impacts to nearby waterbodies or sedimentation impacts to undisturbed lands. Deviations from the SDESC standards should be discussed with the Qualified Inspector/Qualified Professional prior to utilizing the alternative practice. If the alternative practice is acceptable, documentation is required to detail the reasoning for the alternative practice and provide evidence that the alternative design is equivalent to the technical standard. The SWPPP shall be amended as appropriate to incorporate the alternative practice. In the event that an alternative practice fails and a standard SDESC practice is required, the Contractor shall install the required practice upon approval from the Qualified Inspector/ Qualified Professional and Owner/Operator. The SWPPP shall be amended as appropriate to document changes to the practice.

The following sections detail potential stormwater contamination sources due to construction related activities and the temporary and permanent erosion and sediment controls to be utilized

throughout the construction of the Project to mitigate impacts. Refer to the SSESC for additional guidance on installation, maintenance and removal.

9.1 Potential Impacts for Stormwater Contamination

Construction activities and processes that result in either increased stormwater runoff or the potential to add pollutants to runoff are subject to the requirements of this SWPPP. These activities may include areas of land disturbed by grading, excavation, construction, or material storage. Water that comes in contact with the surface of the Project Area as a result of precipitation (snow, hail, rain, etc.) is classified as stormwater associated with the Project and is subject to the requirements of this SWPPP.

Construction activities that may negatively impact stormwater include but are not limited to the following:

- Tree Clearing and Vegetation Removal: Removal of vegetation can expose and weaken soils and may result in erosion.
- Construction Site Entrance: Vehicles leaving the Project Area can track soils onto public roadways.
- Grading Operations: Exposed soils have the potential for erosion and sedimentation when not stabilized.
- Fugitive Dust: Dust generated by vehicles or from strong winds during a drought period can be deposited in wetlands, waterways, and other environmentally sensitive areas, or may negatively impact the air quality.
- General Site Construction Activities: Maintenance and heavy use of access roads can expose soils, creating significant erosion potential. Soil stockpiling from site excavations and grading may promote erosion and sedimentation. Dewatering activities may result in concentrated flows and has the potential to increase erosion.
- Construction Vehicles and Equipment: Refueling of vehicles may result in spilling or dripping gasoline and diesel fuel onto the ground. On-site maintenance of excavating equipment may result in hydraulic oil, lubricants, or antifreeze dripping onto the ground. Sediment tracking and the spread of invasive species may occur if

construction vehicles are improperly maintained. Ruts caused by equipment can create paths for concentrated water flows.

- Waste Management Practices: Typical construction projects often generate significant quantities of solid waste, such as wrappings, personnel-generated trash and waste, and construction debris.

Proper utilization of staging and storage areas, stockpiling areas, and erosion and sediment controls will mitigate potential impacts to the stormwater. Refer to Section 10.1 for additional information on spill prevention and waste management procedures for the Project.

9.2 Protection of Existing Vegetation

Natural vegetation shall be preserved to the maximum extent practicable. Preserving natural vegetation will reduce soil erosion and maintain the inherent integrity of the Project Area. Protection practices may include barrier fencing to prevent equipment and vehicle traffic in vegetated and environmentally sensitive areas.

9.3 Temporary Erosion and Sediment Controls

Temporary erosion and sediment controls shall be utilized to reduce erosion, sedimentation, and pollutants in stormwater discharges, and to prevent impacts to undisturbed areas, natural resources, wetlands, waterbodies, and downstream areas. Both stabilization techniques and structural methods will be utilized, as needed, to meet these objectives.

Temporary erosion and sediment control measures shall be applied during construction to:

- Minimize soil erosion and sedimentation through the stabilization of disturbed areas and removal of sediment from construction site discharges.
- Preserve existing vegetation to the maximum extent practicable and establish permanent vegetation on exposed soils following the completion of soil disturbance activities.
- Minimize the area and duration of soil disturbance through site preparation activities and construction sequencing.

Table 1, below, lists the erosion and sediment controls anticipated to be utilized at the Project Area.

Table 1 - Proposed Erosion and Sediment Control Measures

Construction Road Stabilization	Concrete Truck Washout
Dust Control	Protecting Vegetation During Construction
Site Pollution Prevention	Stabilized Construction Access
Temporary Access Waterway Crossing	Winter Stabilization
Check Dam	Construction Ditch
Dewatering Sump Pit	Flow Diffuser
Flow Spreader	Grassed Waterway
Rock Outlet Protection	Water Bar
Anchored Stabilization Matting	Armored Slope and Channel Stabilization
Fertilizer Application	Fiber Roll
Land Grading	Loose Stabilization Blankets
Mulching	Permanent Construction Area Planting
Soil Restoration	Surface Roughening
Temporary Construction Area Seeding	Top Soiling
Buffer Filter Strip	Cofferdam Structures
Compost Filter Sock	Geotextile Filter Bag
Rock Dam	Silt Fence
Straw Bale Dike	

The standards and specification for the erosion and sediment control measures listed in Table 1 are provided in Appendix G. Refer to the SDESC for the Standards and Specifications of alternate measures and practices, as needed. The temporary erosion and sediment control measures not detailed in the SDESC are detailed below.

9.3.1 Temporary Stockpiling

Temporary stockpiling of granular material (gravel, excavated spoils, select backfill, topsoils, etc.) is expected on site throughout the construction process. Stockpiling of materials is not permitted in areas where health or safety risks are present or where impacts to water quality may occur. Stockpiling is not permitted in wetland or wetland buffer areas.

Stockpile areas shall be contained and protected with the proper erosion and sediment controls such as silt fencing and mulch. Soil stockpiles shall be stabilized with vegetation, geotextile fabric or plastic covers if not utilized for 7 days.

Stockpile areas should be inspected and maintained as needed or directed by the Project Engineer (or Qualified Inspector/Qualified Professional).

9.3.2 Temporary Spoil Stockpiling

Spoil material shall be segregated, conserving topsoil for revegetation and disposing the inorganic sub-soils. Spoils shall be free of construction debris including foreign chunks of concrete, and other construction-related materials.

A spoil disposal plan shall be developed prior to excavation, including the proposed quantities of spoil and the proposed location(s) and procedures for disposal. Spoils shall not be disposed within wetlands, waterbodies, agricultural areas, or other environmentally sensitive areas. Excess topsoil is encouraged to be spread within the immediately disturbed areas, including agricultural areas, if the material is free of rocks. Inorganic spoils shall be buried and capped with the previously stripped, native topsoil to ensure revegetation. Additional topsoil may be required to adequately cover the spoil area. If additional space is needed for on-site disposal, the SWPPP shall be amended as appropriate. For spoils needing to be disposed off-site, the disposal plan shall detail the location of the spoil disposal at an authorized facility off-site.

If the disposal plan does not detail the spoil stockpiling or disposal information, the SWPPP shall be amended as appropriate to document the necessary procedures. The amendment

shall include the anticipated amount of spoils, the spoil stockpiling location, and the disposal method and location.

9.3.3 Construction Access Systems

Temporary construction access systems may be utilized to prevent or reduce impacts to sensitive areas, such as soft soil or wetlands. The construction access systems may include but are not limited to the use of portable mats, plastic roads, or access during frozen weather conditions.

Portable mats are reusable mats typically composed of fiberglass or high-density polyethylene (HDPE). The mats may be used in wetland areas or in areas of soft soils to prevent rutting and soil disturbance impacts.

Plastic road mats are composed of linking HDPE mats using a 1-inch polyvinyl chloride stringer. The mats are utilized to protect wetlands and prevent rutting by distributing the vehicle load across the roadway surface.

Access during frozen conditions may occur once the ground freezes. Snow cover may be packed down or removed for access. The frozen ground conditions will not experience rutting or sediment tracking. Periodic inspection of ground conditions is recommended to ensure frozen ground conditions are present.

Alternative construction access systems shall be approved by the Owner/Operator and the Qualified Professional prior to use. The alternate system shall be documented in the SWPPP amendments.

9.3.4 HDD

To avoid unnecessary disturbance or impact to the bed, banks, and aquatic habitat of the streams, HDD will be utilized for the construction of the pipeline at the stream crossings. The HDD process involves drilling boreholes with a fluid mixture, primarily composed of water and bentonite, a naturally occurring clay. The drilling fluid aids in the removal of cuttings from the borehole, stabilizes the borehole, and acts as a coolant and lubricant

throughout the drilling process. The bentonite-water mixture is not classified as a toxic or hazardous substance, however, if released into waterbodies, bentonite has the potential to temporarily reduce water quality, and therefore, adversely impact fish and other aquatic species.

To protect public health and safety and natural resources, the Contractor shall establish operational procedures and responsibilities for the prevention, containment, and cleanup of inadvertent releases associated with the proposed HDD. The operational procedures should:

1. Minimize the potential for an inadvertent release of drilling fluids associated with HDD activities;
2. Provide for the timely detection of inadvertent returns;
3. Protect environmentally sensitive areas (streams, wetlands, etc.) while responding to an inadvertent release;
4. Ensure an organized, timely and “minimum-impact” response in the event of an inadvertent return and release of drilling fluids; and
5. Ensure that all appropriate notifications are made immediately.

The Contractor shall comply with the Owner’s/Operator’s operational procedures for HDD.

9.4 Temporary Stabilization for Frozen Conditions

Winter stabilization standards apply to construction activities with ongoing soil disturbance and exposure between November 15 and April 1. Temporary winter stabilization measures shall be employed prior to frozen conditions, as detailed in the SSESC.

Erosion and sediment control measures shall be inspected to ensure proper performance and winter stabilization function. Repairs should be made as necessary to prevent erosion and sedimentation during thawing or rain events.

10.0 Construction Pollution Prevention

Proper material storage, handling, and disposal practices shall be implemented during construction to reduce the risk of exposure of materials and hazardous substances to stormwater and environmental resources. The storage, handling, and disposal procedures to be enforced by the Owner/Operator, Contractor(s) and the Qualified Inspector are described below.

10.1 Management of Spills and Releases

The Owner/Operator must be notified in the event of a non-stormwater (fuel, oil, chemical, etc.) spill or release to ensure proper reporting and clean up. The Owner/Operator shall proceed as appropriate in accordance with the Owner/Operator's, local, state, and federal environmental policies and procedures.

A spill or release shall be reported to the NYSDEC Spill Hotline (1-800-457-7362), as applicable, within 2 hours of the release. The Contractor is responsible for retaining documentation containing the NYS spill number and spill information to provide to the Owner/Operator and the Qualified Inspector. The Contractor is responsible for the cleanup and response actions, in accordance with the on-site spill prevention procedures manual. Contaminated soil shall be removed from the Project Area and disposed in accordance with the product specific Safety Data Sheets (SDS) and environmental guidance.

Potential pollutant sources are likely to be stored on the construction site. Bulk petroleum storage (1,100-gallon aboveground tank and/or underground tank) and chemical storage (185-gallon aboveground tank and/or any below ground tank) shall not be present on site. Construction materials typically present on construction sites, as noted in the National Pollutant Discharge Elimination System Construction General Permit, include but are not limited to the following:

- Building Products: Asphalt sealants, copper flashing, roofing materials, adhesives, concrete admixtures, and gravel and/or mulch stockpiles;
- Chemicals: Pesticides, herbicides, insecticides, fertilizers, and landscape materials;
- Petroleum Products: Diesel fuel, oil, hydraulic fluids, gasoline, etc.;

- Hazardous or Toxic Waste: Paints, caulks, sealants, fluorescent light ballasts, solvents, petroleum-based products, wood preservatives, additives, curing compounds, and acids;
- Sanitary Facilities: Portable toilets; and
- Construction Debris: Fill, vegetative debris, stumps, and construction waste.

Specific quantities cannot be estimated until construction methodology and contractor(s) are secured for construction. Spill cleanup and response guidance is provided in Appendix H of this SWPPP.

10.2 Construction Housekeeping

The Owner/Operator or the Contractor shall coordinate with local fire officials regarding on-site fire safety and emergency response. The Contractor shall keep the Construction Supervisor and the Qualified Inspector/Qualified Professional aware of chemicals and waste present on site. The Contractor shall periodically conduct safety inspections at the Project Area to identify housekeeping issues and employ spill prevention procedures.

10.2.1 Material Stockpiling

Material resulting from clearing and grubbing, grading, and other construction activities, or new material delivered to the Project Area, shall be stockpiled upslope of disturbed areas. The stockpile areas shall have the proper erosion and sediment controls installed to prevent the migration of sediments and materials.

10.2.2 Staging, Storage, and Marshalling Areas

Construction materials and equipment should be stored in designated staging areas as indicated on the Preliminary Design Drawings or as directed by the Project Engineer (or Qualified Inspector). The staging, storage, and marshalling areas should be located in an area that minimizes impacts to stormwater quality. Materials shall be properly stored and kept away from water resources and environmentally sensitive areas, including but not limited to wetlands, streams, storm drains, and ditches. or subject to groundwater.

Chemicals, solvents, fertilizers, and other toxic materials must be stored in waterproof containers and must be kept in the proper storage facilities, except during use or application. Runoff containing such materials must be collected and disposed at an approved solid waste or chemical disposal facility.

Bulk storage of materials will be staged at the Project marshalling yard per SDS specification and Environmental Health and Safety Standards, whichever is more restrictive. Contractor marshalling yards may be associated with other projects not covered under this SWPPP and General Permit. If the marshalling area is associated with this SWPPP, the yard shall be inspected by the Qualified Inspector until Project related activities have ceased. A Qualified Inspector shall inspect the marshalling yard to assess for environmental impacts prior to and throughout its use. If additional marshalling yards are required, they must abide by this SWPPP and GP-0-20-001. Amendments shall be made to the SWPPP, as necessary, for the additional marshalling areas.

10.2.3 Equipment Cleaning and Maintenance

All on-site construction vehicles, including employee vehicles, shall be monitored for leaks and shall receive regular preventative maintenance to reduce the risk of leakage. Any equipment leaking oil, fuel, or hydraulic fluid shall be repaired immediately or removed from the Project Area. Construction equipment and Contractor personal vehicles shall be parked, refueled and serviced at least 100 feet from a wetland, waterbody, or other ecologically sensitive area, at an upland location away from conveyance channels, unless approved by the Qualified Inspector/Qualified Professional.

Where there is no reasonable alternative, refueling may occur within these setbacks, but only under the observation of the Qualified Inspector or Trained Contractor and after proper precautions are taken to prevent an accidental spill. The Contractor shall take precautions to ensure that drips, spills, or seeps do not enter the ground. The use of absorbent towels and/or a portable basin beneath the fuel tank is recommended. Refueling activities shall be performed under continual surveillance with extreme care. In the event of a release, the spill shall be promptly cleaned up in accordance with the spill response and clean up procedures.

Petroleum products and hydraulic fluids that are not in vehicles shall be stored in tightly sealed containers that are clearly labeled. All gasoline and fuel storage vessels with greater than a 25-gallon capacity must have secondary containment constructed of an impervious material and be capable of holding 110% of the vessel capacity.

10.2.4 Concrete Washout Areas

Designated concrete washout areas should be provided as needed to allow concrete trucks to wash out or discharge surplus concrete and wash water on site. The concrete washout areas shall be a diked impervious area, located a minimum of 100 feet from a drainage way, waterbody, or wetland area. The concrete washout areas should be designed to prevent contact between the concrete wash and stormwater. The concrete washout areas shall have the proper signage to indicate the location of the facility. The Contractor is responsible for the maintenance of the concrete washout areas. Waste collected at the concrete washout areas shall be disposed as non-hazardous construction waste material.

The washout facility should have sufficient volume to contain the concrete waste resulting from washout and a minimum freeboard of 12 inches. The washout areas should not be filled beyond 95% capacity and shall be cleaned out once 75% capacity has been met unless a new facility has been constructed. Refer to the SSESC for guidance on the construction and use of concrete washout areas.

10.3 Waste Management

The Contractor shall comply with all required regulations governing the on-site management and off-site disposal of solid and hazardous waste generated during construction of the Project. Substances and materials with the potential to pollute surface and groundwaters must be handled, controlled and contained as appropriate to ensure they do not discharge from the Project Area.

A solid waste management program will be implemented to support proper solid waste disposal and recycling practices. Solid waste and debris that cannot be recycled, reused, or salvaged shall be stored in on-site containers for off-site disposal. The containers shall be

emptied periodically by a licensed waste transport service and hauled away from the site for proper disposal. No loose materials shall be allowed at the Project Area and all waste material shall be disposed promptly and properly. The burning of crates, waste, and other refuse is not permitted.

If a hazardous material spill occurs, it must be contained and disposed immediately. Contaminated soil shall be removed from the Project Area and disposed in accordance with product specific SDS and associated guidelines. Reporting spills to the NYSDEC may be required per 17 New York Code, Rules and Regulations 32.3 and 32.4, and the Environmental Conservation Law 17-1734.

11.0 Maintenance Inspections and Reporting Requirements

11.1 Pre-Construction Inspection

A site assessment shall be conducted by the Qualified Inspector prior to commencement of construction activities to ensure erosion and sediment controls have been adequately and appropriately installed. The Contractor is responsible for contacting the Qualified Inspector for the pre-construction inspection following the installation of the erosion and sediment control measures.

11.2 Construction Phase Inspections

A Qualified Inspector shall conduct regular site inspections for the implementation of this SWPPP through final stabilization of the Project Area. Inspections shall occur at an interval of once every seven calendar days unless greater than 5 acres of soil is disturbed at any one time or if the Project Area directly discharges to a 303(d) waterbody segment or is located in one of the watersheds listed in Appendix C of GP-0-20-001, in which inspections shall occur at least twice per every seven calendar days. The two inspections shall be separated by a minimum of 2 full calendar days. Written authorization from the NYSDEC is required prior to disturbance of greater than 5 acres. If a portion of the Project Area is permanently stabilized, inspections can cease in that area as long as the condition has been documented by amending the SWPPP.

The Qualified Inspector shall conduct site inspections to assess the performance of the erosion and sediment controls and identify areas requiring modification or repair. The Qualified Inspector shall complete an inspection report following each inspection.

The Owner/Operator and the Contractor(s) must ensure the erosion and sediment control practices implemented at the Project Area have been maintained in accordance with GP-0-20-001 and the SDESC. The trained Contractor shall regularly inspect the erosion and sediment control practices and pollution prevention measures to ensure they are being maintained in effective operating condition at all times. Corrective actions to the identified deficiencies shall be made within a reasonable time frame.

The Qualified Inspector/Qualified Professional shall inspect the debris removal on a continual basis during construction to ensure proper management and disposal. When construction and restoration are complete, the Contractor is responsible for ensuring the Project Area is free of all construction debris and materials.

11.3 Temporary Construction Activity Suspension

The Contractor must temporarily stabilize all disturbed areas prior to temporary suspension of construction activities. For construction sites where soil disturbance activities have been temporarily suspended and the appropriate temporary stabilization measures have been installed and applied to all disturbed areas, the Qualified Inspector shall begin conducting site inspections in accordance with Part IV.C.2 of GP-0-20-001. The trained Contractor may cease the regular maintenance inspections until soil disturbance activities resume.

The Owner/Operator must notify the NYSDEC Division of Water (DOW) Program contact at the Regional Office in writing prior to reducing the frequency of inspections. Correspondence with the NYSDEC DOW shall be included in Appendix D of this SWPPP.

11.4 Partial Project Completion

Construction sites where soil disturbance activities have been shut down with partial Project completion, the Qualified Inspector can stop conducting inspections once all disturbed areas have achieved final stabilization in conformance with this SWPPP.

The Owner/Operator must notify the NYSDEC DOW Program contact at the Regional Office in writing prior to shut down. Correspondence with the NYSDEC DOW shall be included in Appendix D of this SWPPP.

If soil disturbance activities have ceased for 2 years from the date of shutdown, the Owner/Operator shall have the Qualified Inspector complete a final inspection to certify final stabilization has been achieved and all temporary erosion and sediment control measures have been removed. The Owner/Operator shall complete the NOT form and submit the form to the NYSDEC. A copy of the completed NOT shall be included in Appendix A of this SWPPP.

11.5 Reporting Requirements

Inspection and maintenance reports shall be prepared in accordance with GP-0-20-001 from the commencement of construction activities until the NOT has been submitted to the NYSDEC. The Qualified Inspector shall provide a copy of the completed inspection report to the Owner/Operator and the Contractor(s) within one business day of inspection. A copy of the inspection report shall be included Appendix J of the on-site SWPPP. A blank SWPPP Inspection Form is provided in Appendix J.

11.6 Post-Construction Record Archiving

The Owner/Operator shall retain a copy of the SWPPP, permit coverage forms and associated documentation that were prepared in conjunction with GP-0-20-001 for a period of at least 5 years from the date that the NYSDEC received the completed NOT.

Appendix A – SWPPP Permit Coverage Forms

- Notice of Intent (NOI) -
- SWPPP Preparer Certification Form -
- Owner/Operator Certification Form -
- NYSDEC NOI Acknowledgement Letter for Permit Coverage -
- Notice of Termination (NOT) Form -

Appendix A – Notice of Intent (NOI)

The completed NOI will be included with the Final SWPPP.

NOTICE OF INTENT

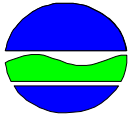

New York State Department of Environmental Conservation
Division of Water
625 Broadway, 4th Floor
Albany, New York 12233-3505

NYR
(For DEC use only)

Stormwater Discharges Associated with Construction Activity Under State Pollutant Discharge Elimination System (SPDES) General Permit # GP-0-15-002
All sections must be completed unless otherwise noted. Failure to complete all items may result in this form being returned to you, thereby delaying your coverage under this General Permit. Applicants must read and understand the conditions of the permit and prepare a Stormwater Pollution Prevention Plan prior to submitting this NOI. Applicants are responsible for identifying and obtaining other DEC permits that may be required.

- IMPORTANT -
RETURN THIS FORM TO THE ADDRESS ABOVE
OWNER/OPERATOR MUST SIGN FORM

Owner/Operator Information

Owner/Operator (Company Name/Private Owner Name/Municipality Name)

Owner/Operator Contact Person Last Name (NOT CONSULTANT)

Owner/Operator Contact Person First Name

Owner/Operator Mailing Address

City

State Zip -

Phone (Owner/Operator) - - Fax (Owner/Operator) - -

Email (Owner/Operator)

FED TAX ID - (not required for individuals)

3. Select the predominant land use for both pre and post development conditions.
SELECT ONLY ONE CHOICE FOR EACH

**Pre-Development
Existing Land Use**

- FOREST
- PASTURE/OPEN LAND
- CULTIVATED LAND
- SINGLE FAMILY HOME
- SINGLE FAMILY SUBDIVISION
- TOWN HOME RESIDENTIAL
- MULTIFAMILY RESIDENTIAL
- INSTITUTIONAL/SCHOOL
- INDUSTRIAL
- COMMERCIAL
- ROAD/HIGHWAY
- RECREATIONAL/SPORTS FIELD
- BIKE PATH/TRAIL
- LINEAR UTILITY
- PARKING LOT
- OTHER

--	--	--	--	--	--	--	--	--	--	--	--	--	--	--	--	--	--	--	--	--

**Post-Development
Future Land Use**

- SINGLE FAMILY HOME
- SINGLE FAMILY SUBDIVISION
- TOWN HOME RESIDENTIAL
- MULTIFAMILY RESIDENTIAL
- INSTITUTIONAL/SCHOOL
- INDUSTRIAL
- COMMERCIAL
- MUNICIPAL
- ROAD/HIGHWAY
- RECREATIONAL/SPORTS FIELD
- BIKE PATH/TRAIL
- LINEAR UTILITY (water, sewer, gas, etc.)
- PARKING LOT
- CLEARING/GRADING ONLY
- DEMOLITION, NO REDEVELOPMENT
- WELL DRILLING ACTIVITY *(Oil, Gas, etc.)
- OTHER

Number of Lots

--	--	--

--	--	--	--	--	--	--	--	--	--	--	--	--	--	--	--	--	--	--	--	--

***Note:** for gas well drilling, non-high volume hydraulic fractured wells only

4. In accordance with the larger common plan of development or sale, enter the total project site area; the total area to be disturbed; existing impervious area to be disturbed (for redevelopment activities); and the future impervious area constructed within the disturbed area. (Round to the nearest tenth of an acre.)

Total Site Area	Total Area To Be Disturbed	Existing Impervious Area To Be Disturbed	Future Impervious Area Within Disturbed Area																				
<table border="1" style="display: inline-table; width: 40px; height: 20px;"> <tr><td></td><td></td><td></td><td></td></tr> </table> . <table border="1" style="display: inline-table; width: 20px; height: 20px;"> <tr><td></td></tr> </table>						<table border="1" style="display: inline-table; width: 40px; height: 20px;"> <tr><td></td><td></td><td></td><td></td></tr> </table> . <table border="1" style="display: inline-table; width: 20px; height: 20px;"> <tr><td></td></tr> </table>						<table border="1" style="display: inline-table; width: 40px; height: 20px;"> <tr><td></td><td></td><td></td><td></td></tr> </table> . <table border="1" style="display: inline-table; width: 20px; height: 20px;"> <tr><td></td></tr> </table>						<table border="1" style="display: inline-table; width: 40px; height: 20px;"> <tr><td></td><td></td><td></td><td></td></tr> </table> . <table border="1" style="display: inline-table; width: 20px; height: 20px;"> <tr><td></td></tr> </table>					

5. Do you plan to disturb more than 5 acres of soil at any one time? Yes No

6. Indicate the percentage of each Hydrologic Soil Group(HSG) at the site.

<table border="1" style="display: inline-table; width: 30px; height: 20px;"> <tr><td></td><td></td><td></td></tr> </table> A				<table border="1" style="display: inline-table; width: 30px; height: 20px;"> <tr><td></td><td></td><td></td></tr> </table> B				<table border="1" style="display: inline-table; width: 30px; height: 20px;"> <tr><td></td><td></td><td></td></tr> </table> C				<table border="1" style="display: inline-table; width: 30px; height: 20px;"> <tr><td></td><td></td><td></td></tr> </table> D			
%	%	%	%												

7. Is this a phased project? Yes No

8. Enter the planned start and end dates of the disturbance activities.

Start Date	End Date																
<table border="1" style="display: inline-table; width: 30px; height: 20px;"> <tr><td></td><td></td></tr> </table> / <table border="1" style="display: inline-table; width: 30px; height: 20px;"> <tr><td></td><td></td></tr> </table> / <table border="1" style="display: inline-table; width: 40px; height: 20px;"> <tr><td></td><td></td><td></td><td></td></tr> </table>									- <table border="1" style="display: inline-table; width: 30px; height: 20px;"> <tr><td></td><td></td></tr> </table> / <table border="1" style="display: inline-table; width: 30px; height: 20px;"> <tr><td></td><td></td></tr> </table> / <table border="1" style="display: inline-table; width: 40px; height: 20px;"> <tr><td></td><td></td><td></td><td></td></tr> </table>								

15. Does the site runoff enter a separate storm sewer system (including roadside drains, swales, ditches, culverts, etc)? Yes No Unknown

16. What is the name of the municipality/entity that owns the separate storm sewer system?

Two rows of empty grid boxes for text entry.

17. Does any runoff from the site enter a sewer classified as a Combined Sewer? Yes No Unknown

18. Will future use of this site be an agricultural property as defined by the NYS Agriculture and Markets Law? Yes No

19. Is this property owned by a state authority, state agency, federal government or local government? Yes No

20. Is this a remediation project being done under a Department approved work plan? (i.e. CERCLA, RCRA, Voluntary Cleanup Agreement, etc.) Yes No

21. Has the required Erosion and Sediment Control component of the SWPPP been developed in conformance with the current NYS Standards and Specifications for Erosion and Sediment Control (aka Blue Book)? Yes No

22. Does this construction activity require the development of a SWPPP that includes the post-construction stormwater management practice component (i.e. Runoff Reduction, Water Quality and Quantity Control practices/techniques)? Yes No
If No, skip questions 23 and 27-39.

23. Has the post-construction stormwater management practice component of the SWPPP been developed in conformance with the current NYS Stormwater Management Design Manual? Yes No

Post-construction Stormwater Management Practice (SMP) Requirements

Important: Completion of Questions 27-39 is not required if response to Question 22 is No.

27. Identify all site planning practices that were used to prepare the final site plan/layout for the project.

- Preservation of Undisturbed Areas
- Preservation of Buffers
- Reduction of Clearing and Grading
- Locating Development in Less Sensitive Areas
- Roadway Reduction
- Sidewalk Reduction
- Driveway Reduction
- Cul-de-sac Reduction
- Building Footprint Reduction
- Parking Reduction

27a. Indicate which of the following soil restoration criteria was used to address the requirements in Section 5.1.6("Soil Restoration") of the Design Manual (2010 version).

- All disturbed areas will be restored in accordance with the Soil Restoration requirements in Table 5.3 of the Design Manual (see page 5-22).
- Compacted areas were considered as impervious cover when calculating the **WQv Required**, and the compacted areas were assigned a post-construction Hydrologic Soil Group (HSG) designation that is one level less permeable than existing conditions for the hydrology analysis.

28. Provide the total Water Quality Volume (WQv) required for this project (based on final site plan/layout).

Total WQv Required

. acre-feet

29. Identify the RR techniques (Area Reduction), RR techniques (Volume Reduction) and Standard SMPs with RRv Capacity in Table 1 (See Page 9) that were used to reduce the Total WQv Required (#28).

Also, provide in Table 1 the total impervious area that contributes runoff to each technique/practice selected. For the Area Reduction Techniques, provide the total contributing area (includes pervious area) and, if applicable, the total impervious area that contributes runoff to the technique/practice.

Note: Redevelopment projects shall use Tables 1 and 2 to identify the SMPs used to treat and/or reduce the WQv required. If runoff reduction techniques will not be used to reduce the required WQv, skip to question 33a after identifying the SMPs.

Table 1 - Runoff Reduction (RR) Techniques and Standard Stormwater Management Practices (SMPs)

<u>RR Techniques (Area Reduction)</u>	<u>Total Contributing Area (acres)</u>		and/or	<u>Total Contributing Impervious Area(acres)</u>	
<input type="radio"/> Conservation of Natural Areas (RR-1) ...	<input type="text"/>	<input type="text"/>		<input type="text"/>	<input type="text"/>
<input type="radio"/> Sheetflow to Riparian Buffers/Filters Strips (RR-2)	<input type="text"/>	<input type="text"/>		<input type="text"/>	<input type="text"/>
<input type="radio"/> Tree Planting/Tree Pit (RR-3)	<input type="text"/>	<input type="text"/>		<input type="text"/>	<input type="text"/>
<input type="radio"/> Disconnection of Rooftop Runoff (RR-4) ..	<input type="text"/>	<input type="text"/>		<input type="text"/>	<input type="text"/>
 <u>RR Techniques (Volume Reduction)</u>					
<input type="radio"/> Vegetated Swale (RR-5)	<input type="text"/>	<input type="text"/>		<input type="text"/>	<input type="text"/>
<input type="radio"/> Rain Garden (RR-6)	<input type="text"/>	<input type="text"/>		<input type="text"/>	<input type="text"/>
<input type="radio"/> Stormwater Planter (RR-7)	<input type="text"/>	<input type="text"/>		<input type="text"/>	<input type="text"/>
<input type="radio"/> Rain Barrel/Cistern (RR-8)	<input type="text"/>	<input type="text"/>		<input type="text"/>	<input type="text"/>
<input type="radio"/> Porous Pavement (RR-9)	<input type="text"/>	<input type="text"/>		<input type="text"/>	<input type="text"/>
<input type="radio"/> Green Roof (RR-10)	<input type="text"/>	<input type="text"/>		<input type="text"/>	<input type="text"/>
 <u>Standard SMPs with RRv Capacity</u>					
<input type="radio"/> Infiltration Trench (I-1)	<input type="text"/>	<input type="text"/>		<input type="text"/>	<input type="text"/>
<input type="radio"/> Infiltration Basin (I-2)	<input type="text"/>	<input type="text"/>		<input type="text"/>	<input type="text"/>
<input type="radio"/> Dry Well (I-3)	<input type="text"/>	<input type="text"/>		<input type="text"/>	<input type="text"/>
<input type="radio"/> Underground Infiltration System (I-4)	<input type="text"/>	<input type="text"/>		<input type="text"/>	<input type="text"/>
<input type="radio"/> Bioretention (F-5)	<input type="text"/>	<input type="text"/>		<input type="text"/>	<input type="text"/>
<input type="radio"/> Dry Swale (O-1)	<input type="text"/>	<input type="text"/>		<input type="text"/>	<input type="text"/>
 <u>Standard SMPs</u>					
<input type="radio"/> Micropool Extended Detention (P-1)	<input type="text"/>	<input type="text"/>		<input type="text"/>	<input type="text"/>
<input type="radio"/> Wet Pond (P-2)	<input type="text"/>	<input type="text"/>		<input type="text"/>	<input type="text"/>
<input type="radio"/> Wet Extended Detention (P-3)	<input type="text"/>	<input type="text"/>		<input type="text"/>	<input type="text"/>
<input type="radio"/> Multiple Pond System (P-4)	<input type="text"/>	<input type="text"/>		<input type="text"/>	<input type="text"/>
<input type="radio"/> Pocket Pond (P-5)	<input type="text"/>	<input type="text"/>		<input type="text"/>	<input type="text"/>
<input type="radio"/> Surface Sand Filter (F-1)	<input type="text"/>	<input type="text"/>		<input type="text"/>	<input type="text"/>
<input type="radio"/> Underground Sand Filter (F-2)	<input type="text"/>	<input type="text"/>		<input type="text"/>	<input type="text"/>
<input type="radio"/> Perimeter Sand Filter (F-3)	<input type="text"/>	<input type="text"/>		<input type="text"/>	<input type="text"/>
<input type="radio"/> Organic Filter (F-4)	<input type="text"/>	<input type="text"/>		<input type="text"/>	<input type="text"/>
<input type="radio"/> Shallow Wetland (W-1)	<input type="text"/>	<input type="text"/>		<input type="text"/>	<input type="text"/>
<input type="radio"/> Extended Detention Wetland (W-2)	<input type="text"/>	<input type="text"/>		<input type="text"/>	<input type="text"/>
<input type="radio"/> Pond/Wetland System (W-3)	<input type="text"/>	<input type="text"/>		<input type="text"/>	<input type="text"/>
<input type="radio"/> Pocket Wetland (W-4)	<input type="text"/>	<input type="text"/>		<input type="text"/>	<input type="text"/>
<input type="radio"/> Wet Swale (O-2)	<input type="text"/>	<input type="text"/>		<input type="text"/>	<input type="text"/>

33. Identify the Standard SMPs in Table 1 and, if applicable, the Alternative SMPs in Table 2 that were used to treat the remaining total WQv(=Total WQv Required in 28 - Total RRv Provided in 30).

Also, provide in Table 1 and 2 the total impervious area that contributes runoff to each practice selected.

Note: Use Tables 1 and 2 to identify the SMPs used on Redevelopment projects.

33a. Indicate the Total WQv provided (i.e. WQv treated) by the SMPs identified in question #33 and Standard SMPs with RRv Capacity identified in question 29.

WQv Provided

						
--	--	--	--	---	--	--	--	--	---	--	--	--	--	---	--	--	--	--	---	--	--	--	--	---	--	--	--	--	---	--	--	--	--	---	--	--	--	--	---	--	--	--	--	---	--	--	--	--	---	--	--	--	--	---	--	--	--	--	---	--	--	--	--	---	--	--	--	--	---	--	--	--	--	---	--	--	--	--	---	--	--	--	--	---	--	--	--	--	---	--	--	--	--	---	--	--	--	--	---	--	--	--	--	---	--	--	--	--	---	--	--	--	--	---	--	--	--	--	---	--	--	--	--	---	--	--	--	--	---	--	--	--	--	---	--	--	--	--	---	--	--	--	--	---	--	--	--	--	---	--	--	--	--	---	--	--	--	--	---	--	--	--	--	---	--	--	--	--	---	--	--	--	--	---	--	--	--	--	---	--	--	--	--	---	--	--	--	--	---	--	--	--	--	---	--	--	--	--	---	--	--	--	--	---	--	--	--	--	---	--	--	--	--	---	--	--	--	--	---	--	--	--	--	---	--	--	--	--	---	--	--	--	--	---	--	--	--	--	---	--	--	--	--	---	--	--	--	--	---	--	--	--	--	---	--	--	--	--	---	--	--	--	--	---	--	--	--	--	---	--	--	--	--	---	--	--	--	--	---	--	--	--	--	---	--	--	--	--	---	--	--	--	--	---	--	--	--	--	---	--	--	--	--	---	--	--	--	--	---	--	--	--	--	---	--	--	--	--	---	--	--	--	--	---	--	--	--	--	---	--	--	--	--	---	--	--	--	--	---	--	--	--	--	---	--	--	--	--	---	--	--	--	--	---	--	--	--	--	---	--	--	--	--	---	--	--	--	--	---	--	--	--	--	---	--	--	--	--	---	--	--	--	--	---	--	--	--	--	---	--	--	--	--	---	--	--	--	--	---	--	--	--	--	---	--	--	--	--	---	--	--	--	--	---	--	--	--	--	---	--	--	--	--	---	--	--	--	--	---	--	--	--	--	---	--	--	--	--	---	--	--	--	--	---	--	--	--	--	---	--	--	--

Appendix A – SWPPP Preparer Certification Form

The signed SWPPP Preparer Certification Form will be included with the Final SWPPP.



SWPPP Preparer Certification Form

*SPDES General Permit for Stormwater
Discharges From Construction Activity
(GP-0-20-001)*

Project Site Information Project/Site Name

Owner/Operator Information Owner/Operator (Company Name/Private Owner/Municipality Name)

Certification Statement – SWPPP Preparer

I hereby certify that the Stormwater Pollution Prevention Plan (SWPPP) for this project has been prepared in accordance with the terms and conditions of the GP-0-20-001. Furthermore, I understand that certifying false, incorrect or inaccurate information is a violation of this permit and the laws of the State of New York and could subject me to criminal, civil and/or administrative proceedings.

First name

MI

Last Name

Signature

Date

Appendix A – Owner/Operator Certification Form

The signed Owner/Operator Certification Form will be included with the Final SWPPP.



Owner/Operator Certification Form

SPDES General Permit For Stormwater Discharges From Construction Activity (GP-0-20-001)

Project/Site Name: _____

eNOI Submission Number: _____

eNOI Submitted by: Owner/Operator SWPPP Preparer Other

Certification Statement - Owner/Operator

I have read or been advised of the permit conditions and believe that I understand them. I also understand that, under the terms of the permit, there may be reporting requirements. I hereby certify that this document and the corresponding documents were prepared under my direction or supervision. I am aware that there are significant penalties for submitting false information, including the possibility of fine and imprisonment for knowing violations. I further understand that coverage under the general permit will be identified in the acknowledgment that I will receive as a result of submitting this NOI and can be as long as sixty (60) business days as provided for in the general permit. I also understand that, by submitting this NOI, I am acknowledging that the SWPPP has been developed and will be implemented as the first element of construction, and agreeing to comply with all the terms and conditions of the general permit for which this NOI is being submitted.

Owner/Operator First Name

M.I. Last Name

Signature

Date

Appendix A – NYSDEC NOI Acknowledgement Letter for Permit Coverage

The NOI Acknowledgement Letter will be included with the Final SWPPP.

Appendix A – Notice of Termination (NOT) Form

**New York State Department of Environmental Conservation
 Division of Water
 625 Broadway, 4th Floor
 Albany, New York 12233-3505
 *(NOTE: Submit completed form to address above)***

**NOTICE OF TERMINATION for Storm Water Discharges Authorized
 under the SPDES General Permit for Construction Activity**

Please indicate your permit identification number: NYR _____

I. Owner or Operator Information

1. Owner/Operator Name:

2. Street Address:

3. City/State/Zip:

4. Contact Person:

4a. Telephone:

4b. Contact Person E-Mail:

II. Project Site Information

5. Project/Site Name:

6. Street Address:

7. City/Zip:

8. County:

III. Reason for Termination

9a. All disturbed areas have achieved final stabilization in accordance with the general permit and SWPPP. ***Date final stabilization completed** (month/year): _____

9b. Permit coverage has been transferred to new owner/operator. Indicate new owner/operator's permit identification number: NYR _____
 (Note: Permit coverage can not be terminated by owner identified in I.1. above until new owner/operator obtains coverage under the general permit)

9c. Other (Explain on Page 2)

IV. Final Site Information:

10a. Did this construction activity require the development of a SWPPP that includes post-construction stormwater management practices? yes no (If no, go to question 10f.)

10b. Have all post-construction stormwater management practices included in the final SWPPP been constructed? yes no (If no, explain on Page 2)

10c. Identify the entity responsible for long-term operation and maintenance of practice(s)?

**NOTICE OF TERMINATION for Storm Water Discharges Authorized under the
SPDES General Permit for Construction Activity - continued**

10d. Has the entity responsible for long-term operation and maintenance been given a copy of the operation and maintenance plan required by the general permit? yes no

10e. Indicate the method used to ensure long-term operation and maintenance of the post-construction stormwater management practice(s):

- Post-construction stormwater management practice(s) and any right-of-way(s) needed to maintain practice(s) have been deeded to the municipality.
- Executed maintenance agreement is in place with the municipality that will maintain the post-construction stormwater management practice(s).
- For post-construction stormwater management practices that are privately owned, a mechanism is in place that requires operation and maintenance of the practice(s) in accordance with the operation and maintenance plan, such as a deed covenant in the owner or operator's deed of record.
- For post-construction stormwater management practices that are owned by a public or private institution (e.g. school, university or hospital), government agency or authority, or public utility; policy and procedures are in place that ensures operation and maintenance of the practice(s) in accordance with the operation and maintenance plan.

10f. Provide the total area of impervious surface (i.e. roof, pavement, concrete, gravel, etc.) constructed within the disturbance area? _____
(acres)

11. Is this project subject to the requirements of a regulated, traditional land use control MS4? yes
 no
(If Yes, complete section VI - "MS4 Acceptance" statement

V. Additional Information/Explanation:
(Use this section to answer questions 9c. and 10b., if applicable)

VI. MS4 Acceptance - MS4 Official (principal executive officer or ranking elected official) or Duly Authorized Representative (Note: Not required when 9b. is checked -transfer of coverage)

I have determined that it is acceptable for the owner or operator of the construction project identified in question 5 to submit the Notice of Termination at this time.

Printed Name:

Title/Position:

Signature:

Date:

**NOTICE OF TERMINATION for Storm Water Discharges Authorized under the
SPDES General Permit for Construction Activity - continued**

VII. Qualified Inspector Certification - Final Stabilization:

I hereby certify that all disturbed areas have achieved final stabilization as defined in the current version of the general permit, and that all temporary, structural erosion and sediment control measures have been removed. Furthermore, I understand that certifying false, incorrect or inaccurate information is a violation of the referenced permit and the laws of the State of New York and could subject me to criminal, civil and/or administrative proceedings.

Printed Name:

Title/Position:

Signature:

Date:

VIII. Qualified Inspector Certification - Post-construction Stormwater Management Practice(s):

I hereby certify that all post-construction stormwater management practices have been constructed in conformance with the SWPPP. Furthermore, I understand that certifying false, incorrect or inaccurate information is a violation of the referenced permit and the laws of the State of New York and could subject me to criminal, civil and/or administrative proceedings.

Printed Name:

Title/Position:

Signature:

Date:

IX. Owner or Operator Certification

I hereby certify that this document was prepared by me or under my direction or supervision. My determination, based upon my inquiry of the person(s) who managed the construction activity, or those persons directly responsible for gathering the information, is that the information provided in this document is true, accurate and complete. Furthermore, I understand that certifying false, incorrect or inaccurate information is a violation of the referenced permit and the laws of the State of New York and could subject me to criminal, civil and/or administrative proceedings.

Printed Name:

Title/Position:

Signature:

Date:

Appendix B – General Permit GP-0-20-001



Department of
Environmental
Conservation

NEW YORK STATE
DEPARTMENT OF ENVIRONMENTAL CONSERVATION

SPDES GENERAL PERMIT
FOR STORMWATER DISCHARGES

From

CONSTRUCTION ACTIVITY

Permit No. GP- 0-20-001

Issued Pursuant to Article 17, Titles 7, 8 and Article 70
of the Environmental Conservation Law

Effective Date: January 29, 2020

Expiration Date: January 28, 2025

John J. Ferguson

Chief Permit Administrator

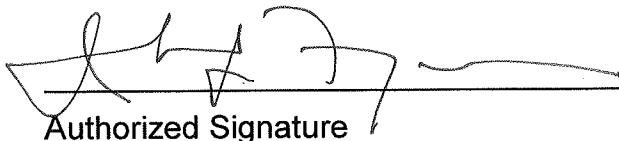

Authorized Signature

1-23-20

Date

Address: NYS DEC
Division of Environmental Permits
625 Broadway, 4th Floor
Albany, N.Y. 12233-1750

PREFACE

Pursuant to Section 402 of the Clean Water Act (“CWA”), stormwater *discharges* from certain *construction activities* are unlawful unless they are authorized by a *National Pollutant Discharge Elimination System (“NPDES”)* permit or by a state permit program. New York administers the approved State Pollutant Discharge Elimination System (SPDES) program with permits issued in accordance with the New York State Environmental Conservation Law (ECL) Article 17, Titles 7, 8 and Article 70.

An *owner or operator* of a *construction activity* that is eligible for coverage under this permit must obtain coverage prior to the *commencement of construction activity*. Activities that fit the definition of “*construction activity*”, as defined under 40 CFR 122.26(b)(14)(x), (15)(i), and (15)(ii), constitute construction of a *point source* and therefore, pursuant to ECL section 17-0505 and 17-0701, the *owner or operator* must have coverage under a SPDES permit prior to *commencing construction activity*. The *owner or operator* cannot wait until there is an actual *discharge* from the *construction site* to obtain permit coverage.

***Note: The italicized words/phrases within this permit are defined in Appendix A.**

**NEW YORK STATE DEPARTMENT OF ENVIRONMENTAL CONSERVATION
SPDES GENERAL PERMIT FOR STORMWATER DISCHARGES FROM
CONSTRUCTION ACTIVITIES**

Table of Contents

Part 1. PERMIT COVERAGE AND LIMITATIONS	1
A. Permit Application	1
B. Effluent Limitations Applicable to Discharges from Construction Activities	1
C. Post-construction Stormwater Management Practice Requirements	4
D. Maintaining Water Quality	8
E. Eligibility Under This General Permit.....	9
F. Activities Which Are Ineligible for Coverage Under This General Permit	9
Part II. PERMIT COVERAGE	12
A. How to Obtain Coverage	12
B. Notice of Intent (NOI) Submittal	13
C. Permit Authorization	13
D. General Requirements For Owners or Operators With Permit Coverage	15
E. Permit Coverage for Discharges Authorized Under GP-0-15-002.....	17
F. Change of Owner or Operator	17
Part III. STORMWATER POLLUTION PREVENTION PLAN (SWPPP).....	18
A. General SWPPP Requirements	18
B. Required SWPPP Contents	20
C. Required SWPPP Components by Project Type.....	24
Part IV. INSPECTION AND MAINTENANCE REQUIREMENTS	24
A. General Construction Site Inspection and Maintenance Requirements	24
B. Contractor Maintenance Inspection Requirements	24
C. Qualified Inspector Inspection Requirements	25
Part V. TERMINATION OF PERMIT COVERAGE	29
A. Termination of Permit Coverage	29
Part VI. REPORTING AND RETENTION RECORDS	31
A. Record Retention	31
B. Addresses	31
Part VII. STANDARD PERMIT CONDITIONS.....	31
A. Duty to Comply.....	31
B. Continuation of the Expired General Permit.....	32
C. Enforcement.....	32
D. Need to Halt or Reduce Activity Not a Defense.....	32
E. Duty to Mitigate	33
F. Duty to Provide Information.....	33
G. Other Information	33
H. Signatory Requirements.....	33
I. Property Rights	35
J. Severability.....	35

K.	Requirement to Obtain Coverage Under an Alternative Permit.....	35
L.	Proper Operation and Maintenance	36
M.	Inspection and Entry	36
N.	Permit Actions	37
O.	Definitions	37
P.	Re-Opener Clause	37
Q.	Penalties for Falsification of Forms and Reports.....	37
R.	Other Permits	38
APPENDIX A – Acronyms and Definitions		39
	Acronyms.....	39
	Definitions.....	40
APPENDIX B – Required SWPPP Components by Project Type		48
	Table 1.....	48
	Table 2.....	50
APPENDIX C – Watersheds Requiring Enhanced Phosphorus Removal.....		52
APPENDIX D – Watersheds with Lower Disturbance Threshold		58
APPENDIX E – 303(d) Segments Impaired by Construction Related Pollutant(s)		59
APPENDIX F – List of NYS DEC Regional Offices		65

Part 1. PERMIT COVERAGE AND LIMITATIONS

A. Permit Application

This permit authorizes stormwater *discharges to surface waters of the State* from the following *construction activities* identified within 40 CFR Parts 122.26(b)(14)(x), 122.26(b)(15)(i) and 122.26(b)(15)(ii), provided all of the eligibility provisions of this permit are met:

1. *Construction activities* involving soil disturbances of one (1) or more acres; including disturbances of less than one acre that are part of a *larger common plan of development or sale* that will ultimately disturb one or more acres of land; excluding *routine maintenance activity* that is performed to maintain the original line and grade, hydraulic capacity or original purpose of a facility;
2. *Construction activities* involving soil disturbances of less than one (1) acre where the Department has determined that a *SPDES* permit is required for stormwater *discharges* based on the potential for contribution to a violation of a *water quality standard* or for significant contribution of *pollutants to surface waters of the State*.
3. *Construction activities* located in the watershed(s) identified in Appendix D that involve soil disturbances between five thousand (5,000) square feet and one (1) acre of land.

B. Effluent Limitations Applicable to Discharges from Construction Activities

Discharges authorized by this permit must achieve, at a minimum, the effluent limitations in Part I.B.1. (a) – (f) of this permit. These limitations represent the degree of effluent reduction attainable by the application of best practicable technology currently available.

1. Erosion and Sediment Control Requirements - The *owner or operator* must select, design, install, implement and maintain control measures to *minimize the discharge of pollutants* and prevent a violation of the *water quality standards*. The selection, design, installation, implementation, and maintenance of these control measures must meet the non-numeric effluent limitations in Part I.B.1.(a) – (f) of this permit and be in accordance with the New York State Standards and Specifications for Erosion and Sediment Control, dated November 2016, using sound engineering judgment. Where control measures are not designed in conformance with the design criteria included in the technical standard, the *owner or operator* must include in the *Stormwater Pollution Prevention Plan* (“SWPPP”) the reason(s) for the

deviation or alternative design and provide information which demonstrates that the deviation or alternative design is *equivalent* to the technical standard.

- a. **Erosion and Sediment Controls.** Design, install and maintain effective erosion and sediment controls to *minimize* the *discharge of pollutants* and prevent a violation of the *water quality standards*. At a minimum, such controls must be designed, installed and maintained to:
- (i) *Minimize* soil erosion through application of runoff control and soil stabilization control measure to *minimize pollutant discharges*;
 - (ii) Control stormwater *discharges*, including both peak flowrates and total stormwater volume, to *minimize* channel and *streambank* erosion and scour in the immediate vicinity of the *discharge* points;
 - (iii) *Minimize* the amount of soil exposed during *construction activity*;
 - (iv) *Minimize* the disturbance of *steep slopes*;
 - (v) *Minimize* sediment *discharges* from the site;
 - (vi) Provide and maintain *natural buffers* around surface waters, direct stormwater to vegetated areas and maximize stormwater infiltration to reduce *pollutant discharges*, unless *infeasible*;
 - (vii) *Minimize* soil compaction. Minimizing soil compaction is not required where the intended function of a specific area of the site dictates that it be compacted;
 - (viii) Unless *infeasible*, preserve a sufficient amount of topsoil to complete soil restoration and establish a uniform, dense vegetative cover; and
 - (ix) *Minimize* dust. On areas of exposed soil, *minimize* dust through the appropriate application of water or other dust suppression techniques to control the generation of pollutants that could be discharged from the site.
- b. **Soil Stabilization.** In areas where soil disturbance activity has temporarily or permanently ceased, the application of soil stabilization measures must be initiated by the end of the next business day and completed within fourteen (14) days from the date the current soil disturbance activity ceased. For construction sites that *directly discharge* to one of the 303(d) segments

listed in Appendix E or is located in one of the watersheds listed in Appendix C, the application of soil stabilization measures must be initiated by the end of the next business day and completed within seven (7) days from the date the current soil disturbance activity ceased. See Appendix A for definition of *Temporarily Ceased*.

- c. **Dewatering.** *Discharges* from *dewatering* activities, including *discharges* from *dewatering* of trenches and excavations, must be managed by appropriate control measures.

- d. **Pollution Prevention Measures.** Design, install, implement, and maintain effective pollution prevention measures to *minimize* the *discharge* of *pollutants* and prevent a violation of the *water quality standards*. At a minimum, such measures must be designed, installed, implemented and maintained to:
 - (i) *Minimize* the *discharge* of *pollutants* from equipment and vehicle washing, wheel wash water, and other wash waters. This applies to washing operations that use clean water only. Soaps, detergents and solvents cannot be used;

 - (ii) *Minimize* the exposure of building materials, building products, construction wastes, trash, landscape materials, fertilizers, pesticides, herbicides, detergents, sanitary waste, hazardous and toxic waste, and other materials present on the site to precipitation and to stormwater. Minimization of exposure is not required in cases where the exposure to precipitation and to stormwater will not result in a *discharge* of *pollutants*, or where exposure of a specific material or product poses little risk of stormwater contamination (such as final products and materials intended for outdoor use) ; and

 - (iii) Prevent the *discharge* of *pollutants* from spills and leaks and implement chemical spill and leak prevention and response procedures.

- e. **Prohibited Discharges.** The following *discharges* are prohibited:
 - (i) Wastewater from washout of concrete;

 - (ii) Wastewater from washout and cleanout of stucco, paint, form release oils, curing compounds and other construction materials;

- (iii) Fuels, oils, or other *pollutants* used in vehicle and equipment operation and maintenance;
 - (iv) Soaps or solvents used in vehicle and equipment washing; and
 - (v) Toxic or hazardous substances from a spill or other release.
- f. Surface Outlets. When discharging from basins and impoundments, the outlets shall be designed, constructed and maintained in such a manner that sediment does not leave the basin or impoundment and that erosion at or below the outlet does not occur.

C. Post-construction Stormwater Management Practice Requirements

1. The *owner or operator of a construction activity* that requires post-construction stormwater management practices pursuant to Part III.C. of this permit must select, design, install, and maintain the practices to meet the *performance criteria* in the New York State Stormwater Management Design Manual (“Design Manual”), dated January 2015, using sound engineering judgment. Where post-construction stormwater management practices (“SMPs”) are not designed in conformance with the *performance criteria* in the Design Manual, the *owner or operator* must include in the SWPPP the reason(s) for the deviation or alternative design and provide information which demonstrates that the deviation or alternative design is *equivalent* to the technical standard.
2. The *owner or operator of a construction activity* that requires post-construction stormwater management practices pursuant to Part III.C. of this permit must design the practices to meet the applicable *sizing criteria* in Part I.C.2.a., b., c. or d. of this permit.

a. Sizing Criteria for New Development

- (i) Runoff Reduction Volume (“RRv”): Reduce the total Water Quality Volume (“WQv”) by application of RR techniques and standard SMPs with RRv capacity. The total WQv shall be calculated in accordance with the criteria in Section 4.2 of the Design Manual.
- (ii) Minimum RRv and Treatment of Remaining Total WQv: Construction activities that cannot meet the criteria in Part I.C.2.a.(i) of this permit due to site limitations shall direct runoff from all newly constructed impervious areas to a RR technique or standard SMP with RRv capacity unless infeasible. The specific site limitations that prevent the reduction of 100% of the WQv shall be documented in the SWPPP.

For each impervious area that is not directed to a RR technique or standard SMP with RRv capacity, the SWPPP must include documentation which demonstrates that all options were considered and for each option explains why it is considered infeasible.

In no case shall the runoff reduction achieved from the newly constructed impervious areas be less than the Minimum RRv as calculated using the criteria in Section 4.3 of the Design Manual.

The remaining portion of the total WQv that cannot be reduced shall be treated by application of standard SMPs.

- (iii) Channel Protection Volume (“Cpv”): Provide 24 hour extended detention of the post-developed 1-year, 24-hour storm event; remaining after runoff reduction. The Cpv requirement does not apply when:
 - (1) Reduction of the entire Cpv is achieved by application of runoff reduction techniques or infiltration systems, or
 - (2) The site discharges directly to tidal waters, or fifth order or larger streams.

- (iv) *Overbank* Flood Control Criteria (“Qp”): Requires storage to attenuate the post-development 10-year, 24-hour peak discharge rate (Qp) to predevelopment rates. The Qp requirement does not apply when:
 - (1) the site discharges directly to tidal waters or fifth order or larger streams, or
 - (2) A downstream analysis reveals that *overbank* control is not required.

- (v) Extreme Flood Control Criteria (“Qf”): Requires storage to attenuate the post-development 100-year, 24-hour peak discharge rate (Qf) to predevelopment rates. The Qf requirement does not apply when:
 - (1) the site discharges directly to tidal waters or fifth order or larger streams, or
 - (2) A downstream analysis reveals that *overbank* control is not required.

b. Sizing Criteria for New Development in Enhanced Phosphorus Removal Watershed

- (i) Runoff Reduction Volume (RRv): Reduce the total Water Quality Volume (WQv) by application of RR techniques and standard SMPs with RRv capacity. The total WQv is the runoff volume from the 1-year, 24 hour design storm over the post-developed watershed and shall be

calculated in accordance with the criteria in Section 10.3 of the Design Manual.

- (ii) Minimum RRv and Treatment of Remaining Total WQv: *Construction activities* that cannot meet the criteria in Part I.C.2.b.(i) of this permit due to *site limitations* shall direct runoff from all newly constructed *impervious areas* to a RR technique or standard SMP with RRv capacity unless *infeasible*. The specific *site limitations* that prevent the reduction of 100% of the WQv shall be documented in the SWPPP. For each *impervious area* that is not directed to a RR technique or standard SMP with RRv capacity, the SWPPP must include documentation which demonstrates that all options were considered and for each option explains why it is considered *infeasible*.

In no case shall the runoff reduction achieved from the newly constructed *impervious areas* be less than the Minimum RRv as calculated using the criteria in Section 10.3 of the Design Manual. The remaining portion of the total WQv that cannot be reduced shall be treated by application of standard SMPs.

- (iii) Channel Protection Volume (Cpv): Provide 24 hour extended detention of the post-developed 1-year, 24-hour storm event; remaining after runoff reduction. The Cpv requirement does not apply when:
 - (1) Reduction of the entire Cpv is achieved by application of runoff reduction techniques or infiltration systems, or
 - (2) The site *discharges* directly to tidal waters, or fifth order or larger streams.
- (iv) *Overbank* Flood Control Criteria (Qp): Requires storage to attenuate the post-development 10-year, 24-hour peak *discharge* rate (Qp) to predevelopment rates. The Qp requirement does not apply when:
 - (1) the site *discharges* directly to tidal waters or fifth order or larger streams, or
 - (2) A downstream analysis reveals that *overbank* control is not required.
- (v) Extreme Flood Control Criteria (Qf): Requires storage to attenuate the post-development 100-year, 24-hour peak *discharge* rate (Qf) to predevelopment rates. The Qf requirement does not apply when:
 - (1) the site *discharges* directly to tidal waters or fifth order or larger streams, or
 - (2) A downstream analysis reveals that *overbank* control is not required.

c. Sizing Criteria for Redevelopment Activity

- (i) Water Quality Volume (WQv): The WQv treatment objective for *redevelopment activity* shall be addressed by one of the following options. *Redevelopment activities* located in an Enhanced Phosphorus Removal Watershed (see Part III.B.3. and Appendix C of this permit) shall calculate the WQv in accordance with Section 10.3 of the Design Manual. All other *redevelopment activities* shall calculate the WQv in accordance with Section 4.2 of the Design Manual.
- (1) Reduce the existing *impervious cover* by a minimum of 25% of the total disturbed, *impervious area*. The Soil Restoration criteria in Section 5.1.6 of the Design Manual must be applied to all newly created pervious areas, or
 - (2) Capture and treat a minimum of 25% of the WQv from the disturbed, *impervious area* by the application of standard SMPs; or reduce 25% of the WQv from the disturbed, *impervious area* by the application of RR techniques or standard SMPs with RRv capacity., or
 - (3) Capture and treat a minimum of 75% of the WQv from the disturbed, *impervious area* as well as any additional runoff from tributary areas by application of the alternative practices discussed in Sections 9.3 and 9.4 of the Design Manual., or
 - (4) Application of a combination of 1, 2 and 3 above that provide a weighted average of at least two of the above methods. Application of this method shall be in accordance with the criteria in Section 9.2.1(B) (IV) of the Design Manual.

If there is an existing post-construction stormwater management practice located on the site that captures and treats runoff from the *impervious area* that is being disturbed, the WQv treatment option selected must, at a minimum, provide treatment equal to the treatment that was being provided by the existing practice(s) if that treatment is greater than the treatment required by options 1 – 4 above.

- (ii) Channel Protection Volume (Cpv): Not required if there are no changes to hydrology that increase the *discharge* rate from the project site.
- (iii) *Overbank* Flood Control Criteria (Qp): Not required if there are no changes to hydrology that increase the *discharge* rate from the project site.
- (iv) Extreme Flood Control Criteria (Qf): Not required if there are no changes to hydrology that increase the *discharge* rate from the project site

d. Sizing Criteria for Combination of Redevelopment Activity and New Development

Construction projects that include both New Development and Redevelopment Activity shall provide post-construction stormwater management controls that meet the sizing criteria calculated as an aggregate of the Sizing Criteria in Part I.C.2.a. or b. of this permit for the New Development portion of the project and Part I.C.2.c of this permit for Redevelopment Activity portion of the project.

D. Maintaining Water Quality

The Department expects that compliance with the conditions of this permit will control *discharges* necessary to meet applicable *water quality standards*. It shall be a violation of the *ECL* for any discharge to either cause or contribute to a violation of *water quality standards* as contained in Parts 700 through 705 of Title 6 of the Official Compilation of Codes, Rules and Regulations of the State of New York, such as:

1. There shall be no increase in turbidity that will cause a substantial visible contrast to natural conditions;
2. There shall be no increase in suspended, colloidal or settleable solids that will cause deposition or impair the waters for their best usages; and
3. There shall be no residue from oil and floating substances, nor visible oil film, nor globules of grease.

If there is evidence indicating that the stormwater *discharges* authorized by this permit are causing, have the reasonable potential to cause, or are contributing to a violation of the *water quality standards*; the *owner or operator* must take appropriate corrective action in accordance with Part IV.C.5. of this general permit and document in accordance with Part IV.C.4. of this general permit. To address the *water quality standard* violation the *owner or operator* may need to provide additional information, include and implement appropriate controls in the SWPPP to correct the problem, or obtain an individual SPDES permit.

If there is evidence indicating that despite compliance with the terms and conditions of this general permit it is demonstrated that the stormwater *discharges* authorized by this permit are causing or contributing to a violation of *water quality standards*, or if the Department determines that a modification of the permit is necessary to prevent a violation of *water quality standards*, the authorized *discharges* will no longer be eligible for coverage under this permit. The Department may require the *owner or operator* to obtain an individual SPDES permit to continue discharging.

E. Eligibility Under This General Permit

1. This permit may authorize all *discharges* of stormwater from *construction activity* to *surface waters of the State* and *groundwaters* except for ineligible *discharges* identified under subparagraph F. of this Part.
2. Except for non-stormwater *discharges* explicitly listed in the next paragraph, this permit only authorizes stormwater *discharges*; including stormwater runoff, snowmelt runoff, and surface runoff and drainage, from *construction activities*.
3. Notwithstanding paragraphs E.1 and E.2 above, the following non-stormwater discharges are authorized by this permit: those listed in 6 NYCRR 750-1.2(a)(29)(vi), with the following exception: “Discharges from firefighting activities are authorized only when the firefighting activities are emergencies/unplanned”; waters to which other components have not been added that are used to control dust in accordance with the SWPPP; and uncontaminated *discharges* from *construction site* de-watering operations. All non-stormwater discharges must be identified in the SWPPP. Under all circumstances, the *owner or operator* must still comply with *water quality standards* in Part I.D of this permit.
4. The *owner or operator* must maintain permit eligibility to *discharge* under this permit. Any *discharges* that are not compliant with the eligibility conditions of this permit are not authorized by the permit and the *owner or operator* must either apply for a separate permit to cover those ineligible *discharges* or take steps necessary to make the *discharge* eligible for coverage.

F. Activities Which Are Ineligible for Coverage Under This General Permit

All of the following are **not** authorized by this permit:

1. *Discharges* after *construction activities* have been completed and the site has undergone *final stabilization*;
2. *Discharges* that are mixed with sources of non-stormwater other than those expressly authorized under subsection E.3. of this Part and identified in the SWPPP required by this permit;
3. *Discharges* that are required to obtain an individual SPDES permit or another SPDES general permit pursuant to Part VII.K. of this permit;
4. *Construction activities* or *discharges* from *construction activities* that may adversely affect an *endangered or threatened species* unless the *owner or*

operator has obtained a permit issued pursuant to 6 NYCRR Part 182 for the project or the Department has issued a letter of non-jurisdiction for the project. All documentation necessary to demonstrate eligibility shall be maintained on site in accordance with Part II.D.2 of this permit;

5. *Discharges* which either cause or contribute to a violation of *water quality standards* adopted pursuant to the *ECL* and its accompanying regulations;
6. *Construction activities* for residential, commercial and institutional projects:
 - a. Where the *discharges* from the *construction activities* are tributary to waters of the state classified as AA or AA-s; and
 - b. Which are undertaken on land with no existing *impervious cover*; and
 - c. Which disturb one (1) or more acres of land designated on the current United States Department of Agriculture (“USDA”) Soil Survey as Soil Slope Phase “D”, (provided the map unit name is inclusive of slopes greater than 25%), or Soil Slope Phase “E” or “F” (regardless of the map unit name), or a combination of the three designations.
7. *Construction activities* for linear transportation projects and linear utility projects:
 - a. Where the *discharges* from the *construction activities* are tributary to waters of the state classified as AA or AA-s; and
 - b. Which are undertaken on land with no existing *impervious cover*; and
 - c. Which disturb two (2) or more acres of land designated on the current USDA Soil Survey as Soil Slope Phase “D” (provided the map unit name is inclusive of slopes greater than 25%), or Soil Slope Phase “E” or “F” (regardless of the map unit name), or a combination of the three designations.

8. *Construction activities* that have the potential to affect an *historic property*, unless there is documentation that such impacts have been resolved. The following documentation necessary to demonstrate eligibility with this requirement shall be maintained on site in accordance with Part II.D.2 of this permit and made available to the Department in accordance with Part VII.F of this permit:
- a. Documentation that the *construction activity* is not within an archeologically sensitive area indicated on the sensitivity map, and that the *construction activity* is not located on or immediately adjacent to a property listed or determined to be eligible for listing on the National or State Registers of Historic Places, and that there is no new permanent building on the *construction site* within the following distances from a building, structure, or object that is more than 50 years old, or if there is such a new permanent building on the *construction site* within those parameters that NYS Office of Parks, Recreation and Historic Preservation (OPRHP), a Historic Preservation Commission of a Certified Local Government, or a qualified preservation professional has determined that the building, structure, or object more than 50 years old is not historically/archeologically significant.
 - 1-5 acres of disturbance - 20 feet
 - 5-20 acres of disturbance - 50 feet
 - 20+ acres of disturbance - 100 feet, or
 - b. DEC consultation form sent to OPRHP, and copied to the NYS DEC Agency Historic Preservation Officer (APO), and
 - (i) the State Environmental Quality Review (SEQR) Environmental Assessment Form (EAF) with a negative declaration or the Findings Statement, with documentation of OPRHP's agreement with the resolution; or
 - (ii) documentation from OPRHP that the *construction activity* will result in No Impact; or
 - (iii) documentation from OPRHP providing a determination of No Adverse Impact; or
 - (iv) a Letter of Resolution signed by the owner/operator, OPRHP and the DEC APO which allows for this *construction activity* to be eligible for coverage under the general permit in terms of the State Historic Preservation Act (SHPA); or
 - c. Documentation of satisfactory compliance with Section 106 of the National Historic Preservation Act for a coterminous project area:

- (i) No Affect
- (ii) No Adverse Affect
- (iii) Executed Memorandum of Agreement, or

d. Documentation that:

- (i) SHPA Section 14.09 has been completed by NYS DEC or another state agency.
9. *Discharges from construction activities* that are subject to an existing SPDES individual or general permit where a SPDES permit for *construction activity* has been terminated or denied; or where the *owner or operator* has failed to renew an expired individual permit.

Part II. PERMIT COVERAGE

A. How to Obtain Coverage

1. An *owner or operator* of a *construction activity* that is not subject to the requirements of a regulated, traditional land use control MS4 must first prepare a SWPPP in accordance with all applicable requirements of this permit and then submit a completed Notice of Intent (NOI) to the Department to be authorized to discharge under this permit.
2. An *owner or operator* of a *construction activity* that is subject to the requirements of a *regulated, traditional land use control MS4* must first prepare a SWPPP in accordance with all applicable requirements of this permit and then have the SWPPP reviewed and accepted by the *regulated, traditional land use control MS4* prior to submitting the NOI to the Department. The *owner or operator* shall have the “MS4 SWPPP Acceptance” form signed in accordance with Part VII.H., and then submit that form along with a completed NOI to the Department.
3. The requirement for an *owner or operator* to have its SWPPP reviewed and accepted by the *regulated, traditional land use control MS4* prior to submitting the NOI to the Department does not apply to an *owner or operator* that is obtaining permit coverage in accordance with the requirements in Part II.F. (Change of *Owner or Operator*) or where the *owner or operator* of the *construction activity* is the *regulated, traditional land use control MS4* . This exemption does not apply to *construction activities* subject to the New York City Administrative Code.

B. Notice of Intent (NOI) Submittal

1. Prior to December 21, 2020, an owner or operator shall use either the electronic (eNOI) or paper version of the NOI that the Department prepared. Both versions of the NOI are located on the Department's website (<http://www.dec.ny.gov/>). The paper version of the NOI shall be signed in accordance with Part VII.H. of this permit and submitted to the following address:

**NOTICE OF INTENT
NYS DEC, Bureau of Water Permits
625 Broadway, 4th Floor
Albany, New York 12233-3505**

2. Beginning December 21, 2020 and in accordance with EPA's 2015 NPDES Electronic Reporting Rule (40 CFR Part 127), the *owner or operator* must submit the NOI electronically using the *Department's* online NOI.
3. The *owner or operator* shall have the SWPPP preparer sign the "SWPPP Preparer Certification" statement on the NOI prior to submitting the form to the Department.
4. As of the date the NOI is submitted to the Department, the *owner or operator* shall make the NOI and SWPPP available for review and copying in accordance with the requirements in Part VII.F. of this permit.

C. Permit Authorization

1. An *owner or operator* shall not *commence construction activity* until their authorization to *discharge* under this permit goes into effect.
2. Authorization to *discharge* under this permit will be effective when the *owner or operator* has satisfied all of the following criteria:
 - a. project review pursuant to the State Environmental Quality Review Act ("SEQRA") have been satisfied, when SEQRA is applicable. See the Department's website (<http://www.dec.ny.gov/>) for more information,
 - b. where required, all necessary Department permits subject to the *Uniform Procedures Act ("UPA")* (see 6 NYCRR Part 621), or the equivalent from another New York State agency, have been obtained, unless otherwise notified by the Department pursuant to 6 NYCRR 621.3(a)(4). *Owners or operators of construction activities* that are required to obtain *UPA* permits

must submit a preliminary SWPPP to the appropriate DEC Permit Administrator at the Regional Office listed in Appendix F at the time all other necessary *UPA* permit applications are submitted. The preliminary SWPPP must include sufficient information to demonstrate that the *construction activity* qualifies for authorization under this permit,

- c. the final SWPPP has been prepared, and
 - d. a complete NOI has been submitted to the Department in accordance with the requirements of this permit.
3. An *owner or operator* that has satisfied the requirements of Part II.C.2 above will be authorized to *discharge* stormwater from their *construction activity* in accordance with the following schedule:
- a. For *construction activities* that are not subject to the requirements of a *regulated, traditional land use control MS4*:
 - (i) Five (5) business days from the date the Department receives a complete electronic version of the NOI (eNOI) for *construction activities* with a SWPPP that has been prepared in conformance with the design criteria in the technical standard referenced in Part III.B.1 and the *performance criteria* in the technical standard referenced in Parts III.B., 2 or 3, for *construction activities* that require post-construction stormwater management practices pursuant to Part III.C.; or
 - (ii) Sixty (60) business days from the date the Department receives a complete NOI (electronic or paper version) for *construction activities* with a SWPPP that has not been prepared in conformance with the design criteria in technical standard referenced in Part III.B.1. or, for *construction activities* that require post-construction stormwater management practices pursuant to Part III.C., the *performance criteria* in the technical standard referenced in Parts III.B., 2 or 3, or;
 - (iii) Ten (10) business days from the date the Department receives a complete paper version of the NOI for *construction activities* with a SWPPP that has been prepared in conformance with the design criteria in the technical standard referenced in Part III.B.1 and the *performance criteria* in the technical standard referenced in Parts III.B., 2 or 3, for *construction activities* that require post-construction stormwater management practices pursuant to Part III.C.

- b. For *construction activities* that are subject to the requirements of a *regulated, traditional land use control MS4*:
 - (i) Five (5) business days from the date the Department receives both a complete electronic version of the NOI (eNOI) and signed “MS4 SWPPP Acceptance” form, or
 - (ii) Ten (10) business days from the date the Department receives both a complete paper version of the NOI and signed “MS4 SWPPP Acceptance” form.
4. Coverage under this permit authorizes stormwater *discharges* from only those areas of disturbance that are identified in the NOI. If an *owner or operator* wishes to have stormwater *discharges* from future or additional areas of disturbance authorized, they must submit a new NOI that addresses that phase of the development, unless otherwise notified by the Department. The *owner or operator* shall not *commence construction activity* on the future or additional areas until their authorization to *discharge* under this permit goes into effect in accordance with Part II.C. of this permit.

D. General Requirements For Owners or Operators With Permit Coverage

1. The *owner or operator* shall ensure that the provisions of the SWPPP are implemented from the *commencement of construction activity* until all areas of disturbance have achieved *final stabilization* and the Notice of Termination (“NOT”) has been submitted to the Department in accordance with Part V. of this permit. This includes any changes made to the SWPPP pursuant to Part III.A.4. of this permit.
2. The *owner or operator* shall maintain a copy of the General Permit (GP-0-20-001), NOI, *NOI Acknowledgment Letter*, SWPPP, MS4 SWPPP Acceptance form, inspection reports, responsible contractor’s or subcontractor’s certification statement (see Part III.A.6.), and all documentation necessary to demonstrate eligibility with this permit at the *construction site* until all disturbed areas have achieved *final stabilization* and the NOT has been submitted to the Department. The documents must be maintained in a secure location, such as a job trailer, on-site construction office, or mailbox with lock. The secure location must be accessible during normal business hours to an individual performing a compliance inspection.
3. The *owner or operator of a construction activity* shall not disturb greater than five (5) acres of soil at any one time without prior written authorization from the Department or, in areas under the jurisdiction of a *regulated, traditional land*

- use control MS4, the regulated, traditional land use control MS4 (provided the regulated, traditional land use control MS4 is not the owner or operator of the construction activity). At a minimum, the owner or operator must comply with the following requirements in order to be authorized to disturb greater than five (5) acres of soil at any one time:*
- a. The *owner or operator* shall have a *qualified inspector* conduct **at least two** (2) site inspections in accordance with Part IV.C. of this permit every seven (7) calendar days, for as long as greater than five (5) acres of soil remain disturbed. The two (2) inspections shall be separated by a minimum of two (2) full calendar days.
 - b. In areas where soil disturbance activity has temporarily or permanently ceased, the application of soil stabilization measures must be initiated by the end of the next business day and completed within seven (7) days from the date the current soil disturbance activity ceased. The soil stabilization measures selected shall be in conformance with the technical standard, New York State Standards and Specifications for Erosion and Sediment Control, dated November 2016.
 - c. The *owner or operator* shall prepare a phasing plan that defines maximum disturbed area per phase and shows required cuts and fills.
 - d. The *owner or operator* shall install any additional site-specific practices needed to protect water quality.
 - e. The *owner or operator* shall include the requirements above in their SWPPP.
4. In accordance with statute, regulations, and the terms and conditions of this permit, the Department may suspend or revoke an *owner's or operator's* coverage under this permit at any time if the Department determines that the SWPPP does not meet the permit requirements or consistent with Part VII.K..
 5. Upon a finding of significant non-compliance with the practices described in the SWPPP or violation of this permit, the Department may order an immediate stop to all activity at the site until the non-compliance is remedied. The stop work order shall be in writing, describe the non-compliance in detail, and be sent to the *owner or operator*.
 6. For *construction activities* that are subject to the requirements of a *regulated, traditional land use control MS4*, the *owner or operator* shall notify the

regulated, traditional land use control MS4 in writing of any planned amendments or modifications to the post-construction stormwater management practice component of the SWPPP required by Part III.A. 4. and 5. of this permit. Unless otherwise notified by the *regulated, traditional land use control MS4*, the *owner or operator* shall have the SWPPP amendments or modifications reviewed and accepted by the *regulated, traditional land use control MS4* prior to commencing construction of the post-construction stormwater management practice.

E. Permit Coverage for Discharges Authorized Under GP-0-15-002

1. Upon renewal of SPDES General Permit for Stormwater Discharges from *Construction Activity* (Permit No. GP-0-15-002), an *owner or operator* of a *construction activity* with coverage under GP-0-15-002, as of the effective date of GP- 0-20-001, shall be authorized to *discharge* in accordance with GP- 0-20-001, unless otherwise notified by the Department.

An *owner or operator* may continue to implement the technical/design components of the post-construction stormwater management controls provided that such design was done in conformance with the technical standards in place at the time of initial project authorization. However, they must comply with the other, non-design provisions of GP-0-20-001.

F. Change of Owner or Operator

1. When property ownership changes or when there is a change in operational control over the construction plans and specifications, the original *owner or operator* must notify the new *owner or operator*, in writing, of the requirement to obtain permit coverage by submitting a NOI with the Department. For *construction activities* subject to the requirements of a *regulated, traditional land use control MS4*, the original *owner or operator* must also notify the MS4, in writing, of the change in ownership at least 30 calendar days prior to the change in ownership.
2. Once the new *owner or operator* obtains permit coverage, the original *owner or operator* shall then submit a completed NOT with the name and permit identification number of the new *owner or operator* to the Department at the address in Part II.B.1. of this permit. If the original *owner or operator* maintains ownership of a portion of the *construction activity* and will disturb soil, they must maintain their coverage under the permit.
3. Permit coverage for the new *owner or operator* will be effective as of the date the Department receives a complete NOI, provided the original *owner or*

operator was not subject to a sixty (60) business day authorization period that has not expired as of the date the Department receives the NOI from the new *owner or operator*.

Part III. STORMWATER POLLUTION PREVENTION PLAN (SWPPP)

A. General SWPPP Requirements

1. A SWPPP shall be prepared and implemented by the *owner or operator* of each *construction activity* covered by this permit. The SWPPP must document the selection, design, installation, implementation and maintenance of the control measures and practices that will be used to meet the effluent limitations in Part I.B. of this permit and where applicable, the post-construction stormwater management practice requirements in Part I.C. of this permit. The SWPPP shall be prepared prior to the submittal of the NOI. The NOI shall be submitted to the Department prior to the *commencement of construction activity*. A copy of the completed, final NOI shall be included in the SWPPP.
2. The SWPPP shall describe the erosion and sediment control practices and where required, post-construction stormwater management practices that will be used and/or constructed to reduce the *pollutants* in stormwater *discharges* and to assure compliance with the terms and conditions of this permit. In addition, the SWPPP shall identify potential sources of pollution which may reasonably be expected to affect the quality of stormwater *discharges*.
3. All SWPPPs that require the post-construction stormwater management practice component shall be prepared by a *qualified professional* that is knowledgeable in the principles and practices of stormwater management and treatment.
4. The *owner or operator* must keep the SWPPP current so that it at all times accurately documents the erosion and sediment controls practices that are being used or will be used during construction, and all post-construction stormwater management practices that will be constructed on the site. At a minimum, the *owner or operator* shall amend the SWPPP, including construction drawings:
 - a. whenever the current provisions prove to be ineffective in minimizing *pollutants* in stormwater *discharges* from the site;

- b. whenever there is a change in design, construction, or operation at the *construction site* that has or could have an effect on the *discharge* of *pollutants*;
 - c. to address issues or deficiencies identified during an inspection by the *qualified inspector*, the Department or other regulatory authority; and
 - d. to document the final construction conditions.
5. The Department may notify the *owner or operator* at any time that the SWPPP does not meet one or more of the minimum requirements of this permit. The notification shall be in writing and identify the provisions of the SWPPP that require modification. Within fourteen (14) calendar days of such notification, or as otherwise indicated by the Department, the *owner or operator* shall make the required changes to the SWPPP and submit written notification to the Department that the changes have been made. If the *owner or operator* does not respond to the Department's comments in the specified time frame, the Department may suspend the *owner's or operator's* coverage under this permit or require the *owner or operator* to obtain coverage under an individual SPDES permit in accordance with Part II.D.4. of this permit.
6. Prior to the *commencement of construction activity*, the *owner or operator* must identify the contractor(s) and subcontractor(s) that will be responsible for installing, constructing, repairing, replacing, inspecting and maintaining the erosion and sediment control practices included in the SWPPP; and the contractor(s) and subcontractor(s) that will be responsible for constructing the post-construction stormwater management practices included in the SWPPP. The *owner or operator* shall have each of the contractors and subcontractors identify at least one person from their company that will be responsible for implementation of the SWPPP. This person shall be known as the *trained contractor*. The *owner or operator* shall ensure that at least one *trained contractor* is on site on a daily basis when soil disturbance activities are being performed.

The *owner or operator* shall have each of the contractors and subcontractors identified above sign a copy of the following certification statement below before they commence any *construction activity*:

"I hereby certify under penalty of law that I understand and agree to comply with the terms and conditions of the SWPPP and agree to implement any corrective actions identified by the *qualified inspector* during a site inspection. I also understand that the *owner or operator* must comply with

the terms and conditions of the most current version of the New York State Pollutant Discharge Elimination System ("SPDES") general permit for stormwater *discharges* from *construction activities* and that it is unlawful for any person to cause or contribute to a violation of *water quality standards*. Furthermore, I am aware that there are significant penalties for submitting false information, that I do not believe to be true, including the possibility of fine and imprisonment for knowing violations"

In addition to providing the certification statement above, the certification page must also identify the specific elements of the SWPPP that each contractor and subcontractor will be responsible for and include the name and title of the person providing the signature; the name and title of the *trained contractor* responsible for SWPPP implementation; the name, address and telephone number of the contracting firm; the address (or other identifying description) of the site; and the date the certification statement is signed. The *owner or operator* shall attach the certification statement(s) to the copy of the SWPPP that is maintained at the *construction site*. If new or additional contractors are hired to implement measures identified in the SWPPP after construction has commenced, they must also sign the certification statement and provide the information listed above.

7. For projects where the Department requests a copy of the SWPPP or inspection reports, the *owner or operator* shall submit the documents in both electronic (PDF only) and paper format within five (5) business days, unless otherwise notified by the Department.

B. Required SWPPP Contents

1. Erosion and sediment control component - All SWPPPs prepared pursuant to this permit shall include erosion and sediment control practices designed in conformance with the technical standard, New York State Standards and Specifications for Erosion and Sediment Control, dated November 2016. Where erosion and sediment control practices are not designed in conformance with the design criteria included in the technical standard, the *owner or operator* must demonstrate *equivalence* to the technical standard. At a minimum, the erosion and sediment control component of the SWPPP shall include the following:
 - a. Background information about the scope of the project, including the location, type and size of project

- b. A site map/construction drawing(s) for the project, including a general location map. At a minimum, the site map shall show the total site area; all improvements; areas of disturbance; areas that will not be disturbed; existing vegetation; on-site and adjacent off-site surface water(s); floodplain/floodway boundaries; wetlands and drainage patterns that could be affected by the *construction activity*; existing and final contours ; locations of different soil types with boundaries; material, waste, borrow or equipment storage areas located on adjacent properties; and location(s) of the stormwater *discharge(s)*;
- c. A description of the soil(s) present at the site, including an identification of the Hydrologic Soil Group (HSG);
- d. A construction phasing plan and sequence of operations describing the intended order of *construction activities*, including clearing and grubbing, excavation and grading, utility and infrastructure installation and any other activity at the site that results in soil disturbance;
- e. A description of the minimum erosion and sediment control practices to be installed or implemented for each *construction activity* that will result in soil disturbance. Include a schedule that identifies the timing of initial placement or implementation of each erosion and sediment control practice and the minimum time frames that each practice should remain in place or be implemented;
- f. A temporary and permanent soil stabilization plan that meets the requirements of this general permit and the technical standard, New York State Standards and Specifications for Erosion and Sediment Control, dated November 2016, for each stage of the project, including initial land clearing and grubbing to project completion and achievement of *final stabilization*;
- g. A site map/construction drawing(s) showing the specific location(s), size(s), and length(s) of each erosion and sediment control practice;
- h. The dimensions, material specifications, installation details, and operation and maintenance requirements for all erosion and sediment control practices. Include the location and sizing of any temporary sediment basins and structural practices that will be used to divert flows from exposed soils;
- i. A maintenance inspection schedule for the contractor(s) identified in Part III.A.6. of this permit, to ensure continuous and effective operation of the erosion and sediment control practices. The maintenance inspection

schedule shall be in accordance with the requirements in the technical standard, New York State Standards and Specifications for Erosion and Sediment Control, dated November 2016;

- j. A description of the pollution prevention measures that will be used to control litter, construction chemicals and construction debris from becoming a *pollutant* source in the stormwater *discharges*;
 - k. A description and location of any stormwater *discharges* associated with industrial activity other than construction at the site, including, but not limited to, stormwater *discharges* from asphalt plants and concrete plants located on the *construction site*; and
 - l. Identification of any elements of the design that are not in conformance with the design criteria in the technical standard, New York State Standards and Specifications for Erosion and Sediment Control, dated November 2016. Include the reason for the deviation or alternative design and provide information which demonstrates that the deviation or alternative design is *equivalent* to the technical standard.
2. Post-construction stormwater management practice component – The *owner or operator* of any construction project identified in Table 2 of Appendix B as needing post-construction stormwater management practices shall prepare a SWPPP that includes practices designed in conformance with the applicable *sizing criteria* in Part I.C.2.a., c. or d. of this permit and the *performance criteria* in the technical standard, New York State Stormwater Management Design Manual dated January 2015

Where post-construction stormwater management practices are not designed in conformance with the *performance criteria* in the technical standard, the *owner or operator* must include in the SWPPP the reason(s) for the deviation or alternative design and provide information which demonstrates that the deviation or alternative design is *equivalent* to the technical standard.

The post-construction stormwater management practice component of the SWPPP shall include the following:

- a. Identification of all post-construction stormwater management practices to be constructed as part of the project. Include the dimensions, material specifications and installation details for each post-construction stormwater management practice;

- b. A site map/construction drawing(s) showing the specific location and size of each post-construction stormwater management practice;
- c. A Stormwater Modeling and Analysis Report that includes:
 - (i) Map(s) showing pre-development conditions, including watershed/subcatchments boundaries, flow paths/routing, and design points;
 - (ii) Map(s) showing post-development conditions, including watershed/subcatchments boundaries, flow paths/routing, design points and post-construction stormwater management practices;
 - (iii) Results of stormwater modeling (i.e. hydrology and hydraulic analysis) for the required storm events. Include supporting calculations (model runs), methodology, and a summary table that compares pre and post-development runoff rates and volumes for the different storm events;
 - (iv) Summary table, with supporting calculations, which demonstrates that each post-construction stormwater management practice has been designed in conformance with the *sizing criteria* included in the Design Manual;
 - (v) Identification of any *sizing criteria* that is not required based on the requirements included in Part I.C. of this permit; and
 - (vi) Identification of any elements of the design that are not in conformance with the *performance criteria* in the Design Manual. Include the reason(s) for the deviation or alternative design and provide information which demonstrates that the deviation or alternative design is *equivalent* to the Design Manual;
- d. Soil testing results and locations (test pits, borings);
- e. Infiltration test results, when required; and
- f. An operations and maintenance plan that includes inspection and maintenance schedules and actions to ensure continuous and effective operation of each post-construction stormwater management practice. The plan shall identify the entity that will be responsible for the long term operation and maintenance of each practice.

3. Enhanced Phosphorus Removal Standards - All construction projects identified in Table 2 of Appendix B that are located in the watersheds identified in Appendix C shall prepare a SWPPP that includes post-construction stormwater management practices designed in conformance with the applicable *sizing criteria* in Part I.C.2. b., c. or d. of this permit and the *performance criteria*, Enhanced Phosphorus Removal Standards included in the Design Manual. At a minimum, the post-construction stormwater management practice component of the SWPPP shall include items 2.a - 2.f. above.

C. Required SWPPP Components by Project Type

Unless otherwise notified by the Department, *owners or operators of construction activities* identified in Table 1 of Appendix B are required to prepare a SWPPP that only includes erosion and sediment control practices designed in conformance with Part III.B.1 of this permit. *Owners or operators of the construction activities* identified in Table 2 of Appendix B shall prepare a SWPPP that also includes post-construction stormwater management practices designed in conformance with Part III.B.2 or 3 of this permit.

Part IV. INSPECTION AND MAINTENANCE REQUIREMENTS

A. General Construction Site Inspection and Maintenance Requirements

1. The *owner or operator* must ensure that all erosion and sediment control practices (including pollution prevention measures) and all post-construction stormwater management practices identified in the SWPPP are inspected and maintained in accordance with Part IV.B. and C. of this permit.
2. The terms of this permit shall not be construed to prohibit the State of New York from exercising any authority pursuant to the ECL, common law or federal law, or prohibit New York State from taking any measures, whether civil or criminal, to prevent violations of the laws of the State of New York or protect the public health and safety and/or the environment.

B. Contractor Maintenance Inspection Requirements

1. The *owner or operator* of each *construction activity* identified in Tables 1 and 2 of Appendix B shall have a *trained contractor* inspect the erosion and sediment control practices and pollution prevention measures being implemented within the active work area daily to ensure that they are being maintained in effective operating condition at all times. If deficiencies are identified, the contractor shall

begin implementing corrective actions within one business day and shall complete the corrective actions in a reasonable time frame.

2. For construction sites where soil disturbance activities have been temporarily suspended (e.g. winter shutdown) and *temporary stabilization* measures have been applied to all disturbed areas, the *trained contractor* can stop conducting the maintenance inspections. The *trained contractor* shall begin conducting the maintenance inspections in accordance with Part IV.B.1. of this permit as soon as soil disturbance activities resume.
3. For construction sites where soil disturbance activities have been shut down with partial project completion, the *trained contractor* can stop conducting the maintenance inspections if all areas disturbed as of the project shutdown date have achieved *final stabilization* and all post-construction stormwater management practices required for the completed portion of the project have been constructed in conformance with the SWPPP and are operational.

C. Qualified Inspector Inspection Requirements

The *owner or operator* shall have a *qualified inspector* conduct site inspections in conformance with the following requirements:

[Note: The *trained contractor* identified in Part III.A.6. and IV.B. of this permit **cannot** conduct the *qualified inspector* site inspections unless they meet the *qualified inspector* qualifications included in Appendix A. In order to perform these inspections, the *trained contractor* would have to be a:

- licensed Professional Engineer,
 - Certified Professional in Erosion and Sediment Control (CPESC),
 - New York State Erosion and Sediment Control Certificate Program holder
 - Registered Landscape Architect, or
 - someone working under the direct supervision of, and at the same company as, the licensed Professional Engineer or Registered Landscape Architect, provided they have received four (4) hours of Department endorsed training in proper erosion and sediment control principles from a Soil and Water Conservation District, or other Department endorsed entity].
1. A *qualified inspector* shall conduct site inspections for all *construction activities* identified in Tables 1 and 2 of Appendix B, with the exception of:
 - a. the construction of a single family residential subdivision with 25% or less *impervious cover* at total site build-out that involves a soil disturbance of one (1) or more acres of land but less than five (5) acres and is not located

in one of the watersheds listed in Appendix C and not directly discharging to one of the 303(d) segments listed in Appendix E;

- b. the construction of a single family home that involves a soil disturbance of one (1) or more acres of land but less than five (5) acres and is not located in one of the watersheds listed in Appendix C and not directly discharging to one of the 303(d) segments listed in Appendix E;
 - c. construction on agricultural property that involves a soil disturbance of one (1) or more acres of land but less than five (5) acres; and
 - d. *construction activities* located in the watersheds identified in Appendix D that involve soil disturbances between five thousand (5,000) square feet and one (1) acre of land.
2. Unless otherwise notified by the Department, the *qualified inspector* shall conduct site inspections in accordance with the following timetable:
- a. For construction sites where soil disturbance activities are on-going, the *qualified inspector* shall conduct a site inspection at least once every seven (7) calendar days.
 - b. For construction sites where soil disturbance activities are on-going and the *owner or operator* has received authorization in accordance with Part II.D.3 to disturb greater than five (5) acres of soil at any one time, the *qualified inspector* shall conduct at least two (2) site inspections every seven (7) calendar days. The two (2) inspections shall be separated by a minimum of two (2) full calendar days.
 - c. For construction sites where soil disturbance activities have been temporarily suspended (e.g. winter shutdown) and *temporary stabilization* measures have been applied to all disturbed areas, the *qualified inspector* shall conduct a site inspection at least once every thirty (30) calendar days. The *owner or operator* shall notify the DOW Water (SPDES) Program contact at the Regional Office (see contact information in Appendix F) or, in areas under the jurisdiction of a *regulated, traditional land use control MS4*, the *regulated, traditional land use control MS4* (provided the *regulated, traditional land use control MS4* is not the *owner or operator* of the *construction activity*) in writing prior to reducing the frequency of inspections.

- d. For construction sites where soil disturbance activities have been shut down with partial project completion, the *qualified inspector* can stop conducting inspections if all areas disturbed as of the project shutdown date have achieved *final stabilization* and all post-construction stormwater management practices required for the completed portion of the project have been constructed in conformance with the SWPPP and are operational. The *owner or operator* shall notify the DOW Water (SPDES) Program contact at the Regional Office (see contact information in Appendix F) or, in areas under the jurisdiction of a *regulated, traditional land use control MS4*, the *regulated, traditional land use control MS4* (provided the *regulated, traditional land use control MS4* is not the *owner or operator* of the *construction activity*) in writing prior to the shutdown. If soil disturbance activities are not resumed within 2 years from the date of shutdown, the *owner or operator* shall have the *qualified inspector* perform a final inspection and certify that all disturbed areas have achieved *final stabilization*, and all temporary, structural erosion and sediment control measures have been removed; and that all post-construction stormwater management practices have been constructed in conformance with the SWPPP by signing the “*Final Stabilization*” and “*Post-Construction Stormwater Management Practice*” certification statements on the NOT. The *owner or operator* shall then submit the completed NOT form to the address in Part II.B.1 of this permit.
 - e. For construction sites that directly *discharge* to one of the 303(d) segments listed in Appendix E or is located in one of the watersheds listed in Appendix C, the *qualified inspector* shall conduct at least two (2) site inspections every seven (7) calendar days. The two (2) inspections shall be separated by a minimum of two (2) full calendar days.
3. At a minimum, the *qualified inspector* shall inspect all erosion and sediment control practices and pollution prevention measures to ensure integrity and effectiveness, all post-construction stormwater management practices under construction to ensure that they are constructed in conformance with the SWPPP, all areas of disturbance that have not achieved *final stabilization*, all points of *discharge* to natural surface waterbodies located within, or immediately adjacent to, the property boundaries of the *construction site*, and all points of *discharge* from the *construction site*.
 4. The *qualified inspector* shall prepare an inspection report subsequent to each and every inspection. At a minimum, the inspection report shall include and/or address the following:

- a. Date and time of inspection;
- b. Name and title of person(s) performing inspection;
- c. A description of the weather and soil conditions (e.g. dry, wet, saturated) at the time of the inspection;
- d. A description of the condition of the runoff at all points of *discharge* from the *construction site*. This shall include identification of any *discharges* of sediment from the *construction site*. Include *discharges* from conveyance systems (i.e. pipes, culverts, ditches, etc.) and overland flow;
- e. A description of the condition of all natural surface waterbodies located within, or immediately adjacent to, the property boundaries of the *construction site* which receive runoff from disturbed areas. This shall include identification of any *discharges* of sediment to the surface waterbody;
- f. Identification of all erosion and sediment control practices and pollution prevention measures that need repair or maintenance;
- g. Identification of all erosion and sediment control practices and pollution prevention measures that were not installed properly or are not functioning as designed and need to be reinstalled or replaced;
- h. Description and sketch of areas with active soil disturbance activity, areas that have been disturbed but are inactive at the time of the inspection, and areas that have been stabilized (temporary and/or final) since the last inspection;
- i. Current phase of construction of all post-construction stormwater management practices and identification of all construction that is not in conformance with the SWPPP and technical standards;
- j. Corrective action(s) that must be taken to install, repair, replace or maintain erosion and sediment control practices and pollution prevention measures; and to correct deficiencies identified with the construction of the post-construction stormwater management practice(s);
- k. Identification and status of all corrective actions that were required by previous inspection; and

- I. Digital photographs, with date stamp, that clearly show the condition of all practices that have been identified as needing corrective actions. The *qualified inspector* shall attach paper color copies of the digital photographs to the inspection report being maintained onsite within seven (7) calendar days of the date of the inspection. The *qualified inspector* shall also take digital photographs, with date stamp, that clearly show the condition of the practice(s) after the corrective action has been completed. The *qualified inspector* shall attach paper color copies of the digital photographs to the inspection report that documents the completion of the corrective action work within seven (7) calendar days of that inspection.
5. Within one business day of the completion of an inspection, the *qualified inspector* shall notify the *owner or operator* and appropriate contractor or subcontractor identified in Part III.A.6. of this permit of any corrective actions that need to be taken. The contractor or subcontractor shall begin implementing the corrective actions within one business day of this notification and shall complete the corrective actions in a reasonable time frame.
6. All inspection reports shall be signed by the *qualified inspector*. Pursuant to Part II.D.2. of this permit, the inspection reports shall be maintained on site with the SWPPP.

Part V. TERMINATION OF PERMIT COVERAGE

A. Termination of Permit Coverage

1. An *owner or operator* that is eligible to terminate coverage under this permit must submit a completed NOT form to the address in Part II.B.1 of this permit. The NOT form shall be one which is associated with this permit, signed in accordance with Part VII.H of this permit.
2. An *owner or operator* may terminate coverage when one or more the following conditions have been met:
 - a. Total project completion - All *construction activity* identified in the SWPPP has been completed; and all areas of disturbance have achieved *final stabilization*; and all temporary, structural erosion and sediment control measures have been removed; and all post-construction stormwater management practices have been constructed in conformance with the SWPPP and are operational;

- b. Planned shutdown with partial project completion - All soil disturbance activities have ceased; and all areas disturbed as of the project shutdown date have achieved *final stabilization*; and all temporary, structural erosion and sediment control measures have been removed; and all post-construction stormwater management practices required for the completed portion of the project have been constructed in conformance with the SWPPP and are operational;
 - c. A new *owner or operator* has obtained coverage under this permit in accordance with Part II.F. of this permit.
 - d. The *owner or operator* obtains coverage under an alternative SPDES general permit or an individual SPDES permit.
3. For *construction activities* meeting subdivision 2a. or 2b. of this Part, the *owner or operator* shall have the *qualified inspector* perform a final site inspection prior to submitting the NOT. The *qualified inspector* shall, by signing the “*Final Stabilization*” and “*Post-Construction Stormwater Management Practice certification statements*” on the NOT, certify that all the requirements in Part V.A.2.a. or b. of this permit have been achieved.
4. For *construction activities* that are subject to the requirements of a *regulated, traditional land use control MS4* and meet subdivision 2a. or 2b. of this Part, the *owner or operator* shall have the *regulated, traditional land use control MS4* sign the “*MS4 Acceptance*” statement on the NOT in accordance with the requirements in Part VII.H. of this permit. The *regulated, traditional land use control MS4* official, by signing this statement, has determined that it is acceptable for the *owner or operator* to submit the NOT in accordance with the requirements of this Part. The *regulated, traditional land use control MS4* can make this determination by performing a final site inspection themselves or by accepting the *qualified inspector’s* final site inspection certification(s) required in Part V.A.3. of this permit.
5. For *construction activities* that require post-construction stormwater management practices and meet subdivision 2a. of this Part, the *owner or operator* must, prior to submitting the NOT, ensure one of the following:
 - a. the post-construction stormwater management practice(s) and any right-of-way(s) needed to maintain such practice(s) have been deeded to the municipality in which the practice(s) is located,

- b. an executed maintenance agreement is in place with the municipality that will maintain the post-construction stormwater management practice(s),
- c. for post-construction stormwater management practices that are privately owned, the *owner or operator* has a mechanism in place that requires operation and maintenance of the practice(s) in accordance with the operation and maintenance plan, such as a deed covenant in the *owner or operator's* deed of record,
- d. for post-construction stormwater management practices that are owned by a public or private institution (e.g. school, university, hospital), government agency or authority, or public utility; the *owner or operator* has policy and procedures in place that ensures operation and maintenance of the practices in accordance with the operation and maintenance plan.

Part VI. REPORTING AND RETENTION RECORDS

A. Record Retention

The *owner or operator* shall retain a copy of the NOI, NOI Acknowledgment Letter, SWPPP, MS4 SWPPP Acceptance form and any inspection reports that were prepared in conjunction with this permit for a period of at least five (5) years from the date that the Department receives a complete NOT submitted in accordance with Part V. of this general permit.

B. Addresses

With the exception of the NOI, NOT, and MS4 SWPPP Acceptance form (which must be submitted to the address referenced in Part II.B.1 of this permit), all written correspondence requested by the Department, including individual permit applications, shall be sent to the address of the appropriate DOW Water (SPDES) Program contact at the Regional Office listed in Appendix F.

Part VII. STANDARD PERMIT CONDITIONS

A. Duty to Comply

The *owner or operator* must comply with all conditions of this permit. All contractors and subcontractors associated with the project must comply with the terms of the SWPPP. Any non-compliance with this permit constitutes a violation of the Clean Water

Act (CWA) and the ECL and is grounds for an enforcement action against the *owner or operator* and/or the contractor/subcontractor; permit revocation, suspension or modification; or denial of a permit renewal application. Upon a finding of significant non-compliance with this permit or the applicable SWPPP, the Department may order an immediate stop to all *construction activity* at the site until the non-compliance is remedied. The stop work order shall be in writing, shall describe the non-compliance in detail, and shall be sent to the *owner or operator*.

If any human remains or archaeological remains are encountered during excavation, the *owner or operator* must immediately cease, or cause to cease, all *construction activity* in the area of the remains and notify the appropriate Regional Water Engineer (RWE). *Construction activity* shall not resume until written permission to do so has been received from the RWE.

B. Continuation of the Expired General Permit

This permit expires five (5) years from the effective date. If a new general permit is not issued prior to the expiration of this general permit, an *owner or operator* with coverage under this permit may continue to operate and *discharge* in accordance with the terms and conditions of this general permit, if it is extended pursuant to the State Administrative Procedure Act and 6 NYCRR Part 621, until a new general permit is issued.

C. Enforcement

Failure of the *owner or operator*, its contractors, subcontractors, agents and/or assigns to strictly adhere to any of the permit requirements contained herein shall constitute a violation of this permit. There are substantial criminal, civil, and administrative penalties associated with violating the provisions of this permit. Fines of up to \$37,500 per day for each violation and imprisonment for up to fifteen (15) years may be assessed depending upon the nature and degree of the offense.

D. Need to Halt or Reduce Activity Not a Defense

It shall not be a defense for an *owner or operator* in an enforcement action that it would have been necessary to halt or reduce the *construction activity* in order to maintain compliance with the conditions of this permit.

E. Duty to Mitigate

The *owner or operator* and its contractors and subcontractors shall take all reasonable steps to *minimize* or prevent any *discharge* in violation of this permit which has a reasonable likelihood of adversely affecting human health or the environment.

F. Duty to Provide Information

The *owner or operator* shall furnish to the Department, within a reasonable specified time period of a written request, all documentation necessary to demonstrate eligibility and any information to determine compliance with this permit or to determine whether cause exists for modifying or revoking this permit, or suspending or denying coverage under this permit, in accordance with the terms and conditions of this permit. The NOI, SWPPP and inspection reports required by this permit are public documents that the *owner or operator* must make available for review and copying by any person within five (5) business days of the *owner or operator* receiving a written request by any such person to review these documents. Copying of documents will be done at the requester's expense.

G. Other Information

When the *owner or operator* becomes aware that they failed to submit any relevant facts, or submitted incorrect information in the NOI or in any of the documents required by this permit, or have made substantive revisions to the SWPPP (e.g. the scope of the project changes significantly, the type of post-construction stormwater management practice(s) changes, there is a reduction in the sizing of the post-construction stormwater management practice, or there is an increase in the disturbance area or *impervious area*), which were not reflected in the original NOI submitted to the Department, they shall promptly submit such facts or information to the Department using the contact information in Part II.A. of this permit. Failure of the *owner or operator* to correct or supplement any relevant facts within five (5) business days of becoming aware of the deficiency shall constitute a violation of this permit.

H. Signatory Requirements

1. All NOIs and NOTs shall be signed as follows:
 - a. For a corporation these forms shall be signed by a responsible corporate officer. For the purpose of this section, a responsible corporate officer means:

- (i) a president, secretary, treasurer, or vice-president of the corporation in charge of a principal business function, or any other person who performs similar policy or decision-making functions for the corporation; or
 - (ii) the manager of one or more manufacturing, production or operating facilities, provided the manager is authorized to make management decisions which govern the operation of the regulated facility including having the explicit or implicit duty of making major capital investment recommendations, and initiating and directing other comprehensive measures to assure long term environmental compliance with environmental laws and regulations; the manager can ensure that the necessary systems are established or actions taken to gather complete and accurate information for permit application requirements; and where authority to sign documents has been assigned or delegated to the manager in accordance with corporate procedures;
 - b. For a partnership or sole proprietorship these forms shall be signed by a general partner or the proprietor, respectively; or
 - c. For a municipality, State, Federal, or other public agency these forms shall be signed by either a principal executive officer or ranking elected official. For purposes of this section, a principal executive officer of a Federal agency includes:
 - (i) the chief executive officer of the agency, or
 - (ii) a senior executive officer having responsibility for the overall operations of a principal geographic unit of the agency (e.g., Regional Administrators of EPA).
2. The SWPPP and other information requested by the Department shall be signed by a person described in Part VII.H.1. of this permit or by a duly authorized representative of that person. A person is a duly authorized representative only if:
- a. The authorization is made in writing by a person described in Part VII.H.1. of this permit;
 - b. The authorization specifies either an individual or a position having responsibility for the overall operation of the regulated facility or activity, such as the position of plant manager, operator of a well or a well field,

superintendent, position of *equivalent* responsibility, or an individual or position having overall responsibility for environmental matters for the company. (A duly authorized representative may thus be either a named individual or any individual occupying a named position) and,

- c. The written authorization shall include the name, title and signature of the authorized representative and be attached to the SWPPP.
3. All inspection reports shall be signed by the *qualified inspector* that performs the inspection.
4. The MS4 SWPPP Acceptance form shall be signed by the principal executive officer or ranking elected official from the *regulated, traditional land use control MS4*, or by a duly authorized representative of that person.

It shall constitute a permit violation if an incorrect and/or improper signatory authorizes any required forms, SWPPP and/or inspection reports.

I. Property Rights

The issuance of this permit does not convey any property rights of any sort, nor any exclusive privileges, nor does it authorize any injury to private property nor any invasion of personal rights, nor any infringement of Federal, State or local laws or regulations. *Owners or operators* must obtain any applicable conveyances, easements, licenses and/or access to real property prior to *commencing construction activity*.

J. Severability

The provisions of this permit are severable, and if any provision of this permit, or the application of any provision of this permit to any circumstance, is held invalid, the application of such provision to other circumstances, and the remainder of this permit shall not be affected thereby.

K. Requirement to Obtain Coverage Under an Alternative Permit

1. The Department may require any owner or operator authorized by this permit to apply for and/or obtain either an individual SPDES permit or another SPDES general permit. When the Department requires any discharger authorized by a general permit to apply for an individual SPDES permit, it shall notify the discharger in writing that a permit application is required. This notice shall

include a brief statement of the reasons for this decision, an application form, a statement setting a time frame for the owner or operator to file the application for an individual SPDES permit, and a deadline, not sooner than 180 days from owner or operator receipt of the notification letter, whereby the authorization to discharge under this general permit shall be terminated. Applications must be submitted to the appropriate Permit Administrator at the Regional Office. The Department may grant additional time upon demonstration, to the satisfaction of the Department, that additional time to apply for an alternative authorization is necessary or where the Department has not provided a permit determination in accordance with Part 621 of this Title.

2. When an individual SPDES permit is issued to a discharger authorized to *discharge* under a general SPDES permit for the same *discharge(s)*, the general permit authorization for outfalls authorized under the individual SPDES permit is automatically terminated on the effective date of the individual permit unless termination is earlier in accordance with 6 NYCRR Part 750.

L. Proper Operation and Maintenance

The *owner or operator* shall at all times properly operate and maintain all facilities and systems of treatment and control (and related appurtenances) which are installed or used by the *owner or operator* to achieve compliance with the conditions of this permit and with the requirements of the SWPPP.

M. Inspection and Entry

The *owner or operator* shall allow an authorized representative of the Department, EPA, applicable county health department, or, in the case of a *construction site* which *discharges* through an *MS4*, an authorized representative of the *MS4* receiving the discharge, upon the presentation of credentials and other documents as may be required by law, to:

1. Enter upon the owner's or operator's premises where a regulated facility or activity is located or conducted or where records must be kept under the conditions of this permit;
2. Have access to and copy at reasonable times, any records that must be kept under the conditions of this permit; and

3. Inspect at reasonable times any facilities or equipment (including monitoring and control equipment), practices or operations regulated or required by this permit.
4. Sample or monitor at reasonable times, for purposes of assuring permit compliance or as otherwise authorized by the Act or ECL, any substances or parameters at any location.

N. Permit Actions

This permit may, at any time, be modified, suspended, revoked, or renewed by the Department in accordance with 6 NYCRR Part 621. The filing of a request by the *owner or operator* for a permit modification, revocation and reissuance, termination, a notification of planned changes or anticipated noncompliance does not limit, diminish and/or stay compliance with any terms of this permit.

O. Definitions

Definitions of key terms are included in Appendix A of this permit.

P. Re-Opener Clause

1. If there is evidence indicating potential or realized impacts on water quality due to any stormwater discharge associated with construction activity covered by this permit, the owner or operator of such discharge may be required to obtain an individual permit or alternative general permit in accordance with Part VII.K. of this permit or the permit may be modified to include different limitations and/or requirements.
2. Any Department initiated permit modification, suspension or revocation will be conducted in accordance with 6 NYCRR Part 621, 6 NYCRR 750-1.18, and 6 NYCRR 750-1.20.

Q. Penalties for Falsification of Forms and Reports

In accordance with 6NYCRR Part 750-2.4 and 750-2.5, any person who knowingly makes any false material statement, representation, or certification in any application, record, report or other document filed or required to be maintained under this permit, including reports of compliance or noncompliance shall, upon conviction, be punished in accordance with ECL §71-1933 and or Articles 175 and 210 of the New York State Penal Law.

R. Other Permits

Nothing in this permit relieves the *owner or operator* from a requirement to obtain any other permits required by law.

APPENDIX A – Acronyms and Definitions

Acronyms

APO – Agency Preservation Officer

BMP – Best Management Practice

CPESC – Certified Professional in Erosion and Sediment Control

Cpv – Channel Protection Volume

CWA – Clean Water Act (or the Federal Water Pollution Control Act, 33 U.S.C. §1251 et seq)

DOW – Division of Water

EAF – Environmental Assessment Form

ECL - Environmental Conservation Law

EPA – U. S. Environmental Protection Agency

HSG – Hydrologic Soil Group

MS4 – Municipal Separate Storm Sewer System

NOI – Notice of Intent

NOT – Notice of Termination

NPDES – National Pollutant Discharge Elimination System

OPRHP – Office of Parks, Recreation and Historic Places

Qf – Extreme Flood

Qp – Overbank Flood

RRv – Runoff Reduction Volume

RWE – Regional Water Engineer

SEQR – State Environmental Quality Review

SEQRA - State Environmental Quality Review Act

SHPA – State Historic Preservation Act

SPDES – State Pollutant Discharge Elimination System

SWPPP – Stormwater Pollution Prevention Plan

TMDL – Total Maximum Daily Load

UPA – Uniform Procedures Act

USDA – United States Department of Agriculture

WQv – Water Quality Volume

Definitions

All definitions in this section are solely for the purposes of this permit.

Agricultural Building – a structure designed and constructed to house farm implements, hay, grain, poultry, livestock or other horticultural products; excluding any structure designed, constructed or used, in whole or in part, for human habitation, as a place of employment where agricultural products are processed, treated or packaged, or as a place used by the public.

Agricultural Property – means the land for construction of a barn, *agricultural building*, silo, stockyard, pen or other structural practices identified in Table II in the “Agricultural Management Practices Catalog for Nonpoint Source Pollution in New York State” prepared by the Department in cooperation with agencies of New York Nonpoint Source Coordinating Committee (dated June 2007).

Alter Hydrology from Pre to Post-Development Conditions - means the post-development peak flow rate(s) has increased by more than 5% of the pre-developed condition for the design storm of interest (e.g. 10 yr and 100 yr).

Combined Sewer - means a sewer that is designed to collect and convey both “sewage” and “stormwater”.

Commence (Commencement of) Construction Activities - means the initial disturbance of soils associated with clearing, grading or excavation activities; or other construction related activities that disturb or expose soils such as demolition, stockpiling of fill material, and the initial installation of erosion and sediment control practices required in the SWPPP. See definition for “*Construction Activity(ies)*” also.

Construction Activity(ies) - means any clearing, grading, excavation, filling, demolition or stockpiling activities that result in soil disturbance. Clearing activities can include, but are not limited to, logging equipment operation, the cutting and skidding of trees, stump removal and/or brush root removal. Construction activity does not include routine maintenance that is performed to maintain the original line and grade, hydraulic capacity, or original purpose of a facility.

Construction Site – means the land area where *construction activity(ies)* will occur. See definition for “*Commence (Commencement of) Construction Activities*” and “*Larger Common Plan of Development or Sale*” also.

Dewatering – means the act of draining rainwater and/or groundwater from building foundations, vaults or excavations/trenches.

Direct Discharge (to a specific surface waterbody) - means that runoff flows from a *construction site* by overland flow and the first point of discharge is the specific surface waterbody, or runoff flows from a *construction site* to a separate storm sewer system

and the first point of discharge from the separate storm sewer system is the specific surface waterbody.

Discharge(s) - means any addition of any pollutant to waters of the State through an outlet or *point source*.

Embankment –means an earthen or rock slope that supports a road/highway.

Endangered or Threatened Species – see 6 NYCRR Part 182 of the Department’s rules and regulations for definition of terms and requirements.

Environmental Conservation Law (ECL) - means chapter 43-B of the Consolidated Laws of the State of New York, entitled the Environmental Conservation Law.

Equivalent (Equivalence) – means that the practice or measure meets all the performance, longevity, maintenance, and safety objectives of the technical standard and will provide an equal or greater degree of water quality protection.

Final Stabilization - means that all soil disturbance activities have ceased and a uniform, perennial vegetative cover with a density of eighty (80) percent over the entire pervious surface has been established; or other equivalent stabilization measures, such as permanent landscape mulches, rock rip-rap or washed/crushed stone have been applied on all disturbed areas that are not covered by permanent structures, concrete or pavement.

General SPDES permit - means a SPDES permit issued pursuant to 6 NYCRR Part 750-1.21 and Section 70-0117 of the ECL authorizing a category of discharges.

Groundwater(s) - means waters in the saturated zone. The saturated zone is a subsurface zone in which all the interstices are filled with water under pressure greater than that of the atmosphere. Although the zone may contain gas-filled interstices or interstices filled with fluids other than water, it is still considered saturated.

Historic Property – means any building, structure, site, object or district that is listed on the State or National Registers of Historic Places or is determined to be eligible for listing on the State or National Registers of Historic Places.

Impervious Area (Cover) - means all impermeable surfaces that cannot effectively infiltrate rainfall. This includes paved, concrete and gravel surfaces (i.e. parking lots, driveways, roads, runways and sidewalks); building rooftops and miscellaneous impermeable structures such as patios, pools, and sheds.

Infeasible – means not technologically possible, or not economically practicable and achievable in light of best industry practices.

Larger Common Plan of Development or Sale - means a contiguous area where multiple separate and distinct *construction activities* are occurring, or will occur, under one plan. The term “plan” in “larger common plan of development or sale” is broadly defined as any announcement or piece of documentation (including a sign, public notice or hearing, marketing plan, advertisement, drawing, permit application, State Environmental Quality Review Act (SEQRA) environmental assessment form or other documents, zoning request, computer design, etc.) or physical demarcation (including boundary signs, lot stakes, surveyor markings, etc.) indicating that *construction activities* may occur on a specific plot.

For discrete construction projects that are located within a larger common plan of development or sale that are at least 1/4 mile apart, each project can be treated as a separate plan of development or sale provided any interconnecting road, pipeline or utility project that is part of the same “common plan” is not concurrently being disturbed.

Minimize – means reduce and/or eliminate to the extent achievable using control measures (including best management practices) that are technologically available and economically practicable and achievable in light of best industry practices.

Municipal Separate Storm Sewer (MS4) - a conveyance or system of conveyances (including roads with drainage systems, municipal streets, catch basins, curbs, gutters, ditches, man-made channels, or storm drains):

- (i) Owned or operated by a State, city, town, borough, county, parish, district, association, or other public body (created by or pursuant to State law) having jurisdiction over disposal of sewage, industrial wastes, stormwater, or other wastes, including special districts under State law such as a sewer district, flood control district or drainage district, or similar entity, or an Indian tribe or an authorized Indian tribal organization, or a designated and approved management agency under section 208 of the CWA that discharges to surface waters of the State;
- (ii) Designed or used for collecting or conveying stormwater;
- (iii) Which is not a *combined sewer*, and
- (iv) Which is not part of a Publicly Owned Treatment Works (POTW) as defined at 40 CFR 122.2.

National Pollutant Discharge Elimination System (NPDES) - means the national system for the issuance of wastewater and stormwater permits under the Federal Water Pollution Control Act (Clean Water Act).

Natural Buffer –means an undisturbed area with natural cover running along a surface water (e.g. wetland, stream, river, lake, etc.).

New Development – means any land disturbance that does not meet the definition of Redevelopment Activity included in this appendix.

New York State Erosion and Sediment Control Certificate Program – a certificate program that establishes and maintains a process to identify and recognize individuals who are capable of developing, designing, inspecting and maintaining erosion and sediment control plans on projects that disturb soils in New York State. The certificate program is administered by the New York State Conservation District Employees Association.

NOI Acknowledgment Letter - means the letter that the Department sends to an owner or operator to acknowledge the Department's receipt and acceptance of a complete Notice of Intent. This letter documents the owner's or operator's authorization to discharge in accordance with the general permit for stormwater discharges from *construction activity*.

Nonpoint Source - means any source of water pollution or pollutants which is not a discrete conveyance or *point source* permitted pursuant to Title 7 or 8 of Article 17 of the Environmental Conservation Law (see ECL Section 17-1403).

Overbank –means flow events that exceed the capacity of the stream channel and spill out into the adjacent floodplain.

Owner or Operator - means the person, persons or legal entity which owns or leases the property on which the *construction activity* is occurring; an entity that has operational control over the construction plans and specifications, including the ability to make modifications to the plans and specifications; and/or an entity that has day-to-day operational control of those activities at a project that are necessary to ensure compliance with the permit conditions.

Performance Criteria – means the design criteria listed under the “Required Elements” sections in Chapters 5, 6 and 10 of the technical standard, New York State Stormwater Management Design Manual, dated January 2015. It does not include the Sizing Criteria (i.e. WQv, RRv, Cpv, Qp and Qf) in Part I.C.2. of the permit.

Point Source - means any discernible, confined and discrete conveyance, including but not limited to any pipe, ditch, channel, tunnel, conduit, well, discrete fissure, container, rolling stock, concentrated animal feeding operation, vessel or other floating craft, or landfill leachate collection system from which *pollutants* are or may be discharged.

Pollutant - means dredged spoil, filter backwash, solid waste, incinerator residue, sewage, garbage, sewage sludge, munitions, chemical wastes, biological materials, radioactive materials, heat, wrecked or discarded equipment, rock, sand and industrial, municipal, agricultural waste and ballast discharged into water; which may cause or might reasonably be expected to cause pollution of the waters of the state in contravention of the standards or guidance values adopted as provided in 6 NYCRR Parts 700 et seq .

Qualified Inspector - means a person that is knowledgeable in the principles and practices of erosion and sediment control, such as a licensed Professional Engineer, Certified Professional in Erosion and Sediment Control (CPESC), Registered Landscape Architect, New York State Erosion and Sediment Control Certificate Program holder or other Department endorsed individual(s).

It can also mean someone working under the direct supervision of, and at the same company as, the licensed Professional Engineer or Registered Landscape Architect, provided that person has training in the principles and practices of erosion and sediment control. Training in the principles and practices of erosion and sediment control means that the individual working under the direct supervision of the licensed Professional Engineer or Registered Landscape Architect has received four (4) hours of Department endorsed training in proper erosion and sediment control principles from a Soil and Water Conservation District, or other Department endorsed entity. After receiving the initial training, the individual working under the direct supervision of the licensed Professional Engineer or Registered Landscape Architect shall receive four (4) hours of training every three (3) years.

It can also mean a person that meets the *Qualified Professional* qualifications in addition to the *Qualified Inspector* qualifications.

Note: Inspections of any post-construction stormwater management practices that include structural components, such as a dam for an impoundment, shall be performed by a licensed Professional Engineer.

Qualified Professional - means a person that is knowledgeable in the principles and practices of stormwater management and treatment, such as a licensed Professional Engineer, Registered Landscape Architect or other Department endorsed individual(s). Individuals preparing SWPPPs that require the post-construction stormwater management practice component must have an understanding of the principles of hydrology, water quality management practice design, water quantity control design, and, in many cases, the principles of hydraulics. All components of the SWPPP that involve the practice of engineering, as defined by the NYS Education Law (see Article 145), shall be prepared by, or under the direct supervision of, a professional engineer licensed to practice in the State of New York.

Redevelopment Activity(ies) – means the disturbance and reconstruction of existing impervious area, including impervious areas that were removed from a project site within five (5) years of preliminary project plan submission to the local government (i.e. site plan, subdivision, etc.).

Regulated, Traditional Land Use Control MS4 - means a city, town or village with land use control authority that is authorized to discharge under New York State DEC's

SPDES General Permit For Stormwater Discharges from Municipal Separate Stormwater Sewer Systems (MS4s) or the City of New York's Individual SPDES Permit for their Municipal Separate Storm Sewer Systems (NY-0287890).

Routine Maintenance Activity - means *construction activity* that is performed to maintain the original line and grade, hydraulic capacity, or original purpose of a facility, including, but not limited to:

- Re-grading of gravel roads or parking lots,
- Cleaning and shaping of existing roadside ditches and culverts that maintains the approximate original line and grade, and hydraulic capacity of the ditch,
- Cleaning and shaping of existing roadside ditches that does not maintain the approximate original grade, hydraulic capacity and purpose of the ditch if the changes to the line and grade, hydraulic capacity or purpose of the ditch are installed to improve water quality and quantity controls (e.g. installing grass lined ditch),
- Placement of aggregate shoulder backing that stabilizes the transition between the road shoulder and the ditch or *embankment*,
- Full depth milling and filling of existing asphalt pavements, replacement of concrete pavement slabs, and similar work that does not expose soil or disturb the bottom six (6) inches of subbase material,
- Long-term use of equipment storage areas at or near highway maintenance facilities,
- Removal of sediment from the edge of the highway to restore a previously existing sheet-flow drainage connection from the highway surface to the highway ditch or *embankment*,
- Existing use of Canal Corp owned upland disposal sites for the canal, and
- Replacement of curbs, gutters, sidewalks and guide rail posts.

Site limitations – means site conditions that prevent the use of an infiltration technique and or infiltration of the total WQv. Typical site limitations include: seasonal high groundwater, shallow depth to bedrock, and soils with an infiltration rate less than 0.5 inches/hour. The existence of site limitations shall be confirmed and documented using actual field testing (i.e. test pits, soil borings, and infiltration test) or using information from the most current United States Department of Agriculture (USDA) Soil Survey for the County where the project is located.

Sizing Criteria – means the criteria included in Part I.C.2 of the permit that are used to size post-construction stormwater management control practices. The criteria include; Water Quality Volume (WQv), Runoff Reduction Volume (RRv), Channel Protection Volume (Cpv), *Overbank Flood* (Qp), and *Extreme Flood* (Qf).

State Pollutant Discharge Elimination System (SPDES) - means the system established pursuant to Article 17 of the ECL and 6 NYCRR Part 750 for issuance of permits authorizing discharges to the waters of the state.

Steep Slope – means land area designated on the current United States Department of Agriculture (“USDA”) Soil Survey as Soil Slope Phase “D”, (provided the map unit name is inclusive of slopes greater than 25%) , or Soil Slope Phase E or F, (regardless of the map unit name), or a combination of the three designations.

Streambank – as used in this permit, means the terrain alongside the bed of a creek or stream. The bank consists of the sides of the channel, between which the flow is confined.

Stormwater Pollution Prevention Plan (SWPPP) – means a project specific report, including construction drawings, that among other things: describes the construction activity(ies), identifies the potential sources of pollution at the *construction site*; describes and shows the stormwater controls that will be used to control the pollutants (i.e. erosion and sediment controls; for many projects, includes post-construction stormwater management controls); and identifies procedures the *owner or operator* will implement to comply with the terms and conditions of the permit. See Part III of the permit for a complete description of the information that must be included in the SWPPP.

Surface Waters of the State - shall be construed to include lakes, bays, sounds, ponds, impounding reservoirs, springs, rivers, streams, creeks, estuaries, marshes, inlets, canals, the Atlantic ocean within the territorial seas of the state of New York and all other bodies of surface water, natural or artificial, inland or coastal, fresh or salt, public or private (except those private waters that do not combine or effect a junction with natural surface waters), which are wholly or partially within or bordering the state or within its jurisdiction. Waters of the state are further defined in 6 NYCRR Parts 800 to 941.

Temporarily Ceased – means that an existing disturbed area will not be disturbed again within 14 calendar days of the previous soil disturbance.

Temporary Stabilization - means that exposed soil has been covered with material(s) as set forth in the technical standard, New York Standards and Specifications for Erosion and Sediment Control, to prevent the exposed soil from eroding. The materials can include, but are not limited to, mulch, seed and mulch, and erosion control mats (e.g. jute twisted yarn, excelsior wood fiber mats).

Total Maximum Daily Loads (TMDLs) - A TMDL is the sum of the allowable loads of a single pollutant from all contributing point and *nonpoint sources*. It is a calculation of the maximum amount of a pollutant that a waterbody can receive on a daily basis and still meet *water quality standards*, and an allocation of that amount to the pollutant's sources. A TMDL stipulates wasteload allocations (WLAs) for *point source* discharges, load allocations (LAs) for *nonpoint sources*, and a margin of safety (MOS).

Trained Contractor - means an employee from the contracting (construction) company, identified in Part III.A.6., that has received four (4) hours of Department endorsed

training in proper erosion and sediment control principles from a Soil and Water Conservation District, or other Department endorsed entity. After receiving the initial training, the *trained contractor* shall receive four (4) hours of training every three (3) years.

It can also mean an employee from the contracting (construction) company, identified in Part III.A.6., that meets the *qualified inspector* qualifications (e.g. licensed Professional Engineer, Certified Professional in Erosion and Sediment Control (CPESC), Registered Landscape Architect, New York State Erosion and Sediment Control Certificate Program holder, or someone working under the direct supervision of, and at the same company as, the licensed Professional Engineer or Registered Landscape Architect, provided they have received four (4) hours of Department endorsed training in proper erosion and sediment control principles from a Soil and Water Conservation District, or other Department endorsed entity).

The *trained contractor* is responsible for the day to day implementation of the SWPPP.

Uniform Procedures Act (UPA) Permit - means a permit required under 6 NYCRR Part 621 of the Environmental Conservation Law (ECL), Article 70.

Water Quality Standard - means such measures of purity or quality for any waters in relation to their reasonable and necessary use as promulgated in 6 NYCRR Part 700 et seq.

APPENDIX B – Required SWPPP Components by Project Type

Table 1
Construction Activities that Require the Preparation of a SWPPP That Only Includes Erosion and Sediment Controls

<p>The following construction activities that involve soil disturbances of one (1) or more acres of land, but less than five (5) acres:</p> <ul style="list-style-type: none">• Single family home <u>not</u> located in one of the watersheds listed in Appendix C or <u>not directly discharging</u> to one of the 303(d) segments listed in Appendix E• Single family residential subdivisions with 25% or less impervious cover at total site build-out and <u>not</u> located in one of the watersheds listed in Appendix C and <u>not</u> directly discharging to one of the 303(d) segments listed in Appendix E• Construction of a barn or other <i>agricultural building</i>, silo, stock yard or pen.
<p>The following construction activities that involve soil disturbances between five thousand (5000) square feet and one (1) acre of land:</p> <p>All construction activities located in the watersheds identified in Appendix D that involve soil disturbances between five thousand (5,000) square feet and one (1) acre of land.</p>
<p>The following construction activities that involve soil disturbances of one (1) or more acres of land:</p> <ul style="list-style-type: none">• Installation of underground, linear utilities; such as gas lines, fiber-optic cable, cable TV, electric, telephone, sewer mains, and water mains• Environmental enhancement projects, such as wetland mitigation projects, stormwater retrofits and stream restoration projects• Pond construction• Linear bike paths running through areas with vegetative cover, including bike paths surfaced with an impervious cover• Cross-country ski trails and walking/hiking trails• Sidewalk, bike path or walking path projects, surfaced with an impervious cover, that are not part of residential, commercial or institutional development;• Sidewalk, bike path or walking path projects, surfaced with an impervious cover, that include incidental shoulder or curb work along an existing highway to support construction of the sidewalk, bike path or walking path.• Slope stabilization projects• Slope flattening that changes the grade of the site, but does not significantly change the runoff characteristics

Table 1 (Continued) CONSTRUCTION ACTIVITIES THAT REQUIRE THE PREPARATION OF A SWPPP THAT ONLY INCLUDES EROSION AND SEDIMENT CONTROLS

The following construction activities that involve soil disturbances of one (1) or more acres of land:

- Spoil areas that will be covered with vegetation
- Vegetated open space projects (i.e. recreational parks, lawns, meadows, fields, downhill ski trails) excluding projects that *alter hydrology from pre to post development* conditions,
- Athletic fields (natural grass) that do not include the construction or reconstruction of *impervious area* and do not *alter hydrology from pre to post development* conditions
- Demolition project where vegetation will be established, and no redevelopment is planned
- Overhead electric transmission line project that does not include the construction of permanent access roads or parking areas surfaced with *impervious cover*
- Structural practices as identified in Table II in the “Agricultural Management Practices Catalog for Nonpoint Source Pollution in New York State”, excluding projects that involve soil disturbances of greater than five acres and construction activities that include the construction or reconstruction of impervious area
- Temporary access roads, median crossovers, detour roads, lanes, or other temporary impervious areas that will be restored to pre-construction conditions once the construction activity is complete

Table 2
CONSTRUCTION ACTIVITIES THAT REQUIRE THE PREPARATION OF A SWPPP THAT INCLUDES
POST-CONSTRUCTION STORMWATER MANAGEMENT PRACTICES

The following construction activities that involve soil disturbances of one (1) or more acres of land:

- Single family home located in one of the watersheds listed in Appendix C or *directly discharging* to one of the 303(d) segments listed in Appendix E
- Single family home that disturbs five (5) or more acres of land
- Single family residential subdivisions located in one of the watersheds listed in Appendix C or *directly discharging* to one of the 303(d) segments listed in Appendix E
- Single family residential subdivisions that involve soil disturbances of between one (1) and five (5) acres of land with greater than 25% impervious cover at total site build-out
- Single family residential subdivisions that involve soil disturbances of five (5) or more acres of land, and single family residential subdivisions that involve soil disturbances of less than five (5) acres that are part of a larger common plan of development or sale that will ultimately disturb five or more acres of land
- Multi-family residential developments; includes duplexes, townhomes, condominiums, senior housing complexes, apartment complexes, and mobile home parks
- Airports
- Amusement parks
- Breweries, cideries, and wineries, including establishments constructed on agricultural land
- Campgrounds
- Cemeteries that include the construction or reconstruction of impervious area (>5% of disturbed area) or *alter the hydrology from pre to post development* conditions
- Commercial developments
- Churches and other places of worship
- Construction of a barn or other *agricultural building* (e.g. silo) and structural practices as identified in Table II in the "Agricultural Management Practices Catalog for Nonpoint Source Pollution in New York State" that include the construction or reconstruction of *impervious area*, excluding projects that involve soil disturbances of less than five acres.
- Golf courses
- Institutional development; includes hospitals, prisons, schools and colleges
- Industrial facilities; includes industrial parks
- Landfills
- Municipal facilities; includes highway garages, transfer stations, office buildings, POTW's, water treatment plants, and water storage tanks
- Office complexes
- Playgrounds that include the construction or reconstruction of impervious area
- Sports complexes
- Racetracks; includes racetracks with earthen (dirt) surface
- Road construction or reconstruction, including roads constructed as part of the construction activities listed in Table 1

Table 2 (Continued)

CONSTRUCTION ACTIVITIES THAT REQUIRE THE PREPARATION OF A SWPPP THAT INCLUDES POST-CONSTRUCTION STORMWATER MANAGEMENT PRACTICES

The following construction activities that involve soil disturbances of one (1) or more acres of land:

- Parking lot construction or reconstruction, including parking lots constructed as part of the construction activities listed in Table 1
- Athletic fields (natural grass) that include the construction or reconstruction of impervious area (>5% of disturbed area) or *alter the hydrology from pre to post development* conditions
- Athletic fields with artificial turf
- Permanent access roads, parking areas, substations, compressor stations and well drilling pads, surfaced with *impervious cover*, and constructed as part of an over-head electric transmission line project, wind-power project, cell tower project, oil or gas well drilling project, sewer or water main project or other linear utility project
- Sidewalk, bike path or walking path projects, surfaced with an impervious cover, that are part of a residential, commercial or institutional development
- Sidewalk, bike path or walking path projects, surfaced with an impervious cover, that are part of a highway construction or reconstruction project
- All other construction activities that include the construction or reconstruction of *impervious area* or *alter the hydrology from pre to post development* conditions, and are not listed in Table 1

APPENDIX C – Watersheds Requiring Enhanced Phosphorus Removal

Watersheds where *owners or operators* of construction activities identified in Table 2 of Appendix B must prepare a SWPPP that includes post-construction stormwater management practices designed in conformance with the Enhanced Phosphorus Removal Standards included in the technical standard, New York State Stormwater Management Design Manual (“Design Manual”).

- Entire New York City Watershed located east of the Hudson River - Figure 1
- Onondaga Lake Watershed - Figure 2
- Greenwood Lake Watershed -Figure 3
- Oscawana Lake Watershed – Figure 4
- Kinderhook Lake Watershed – Figure 5

Figure 1 - New York City Watershed East of the Hudson

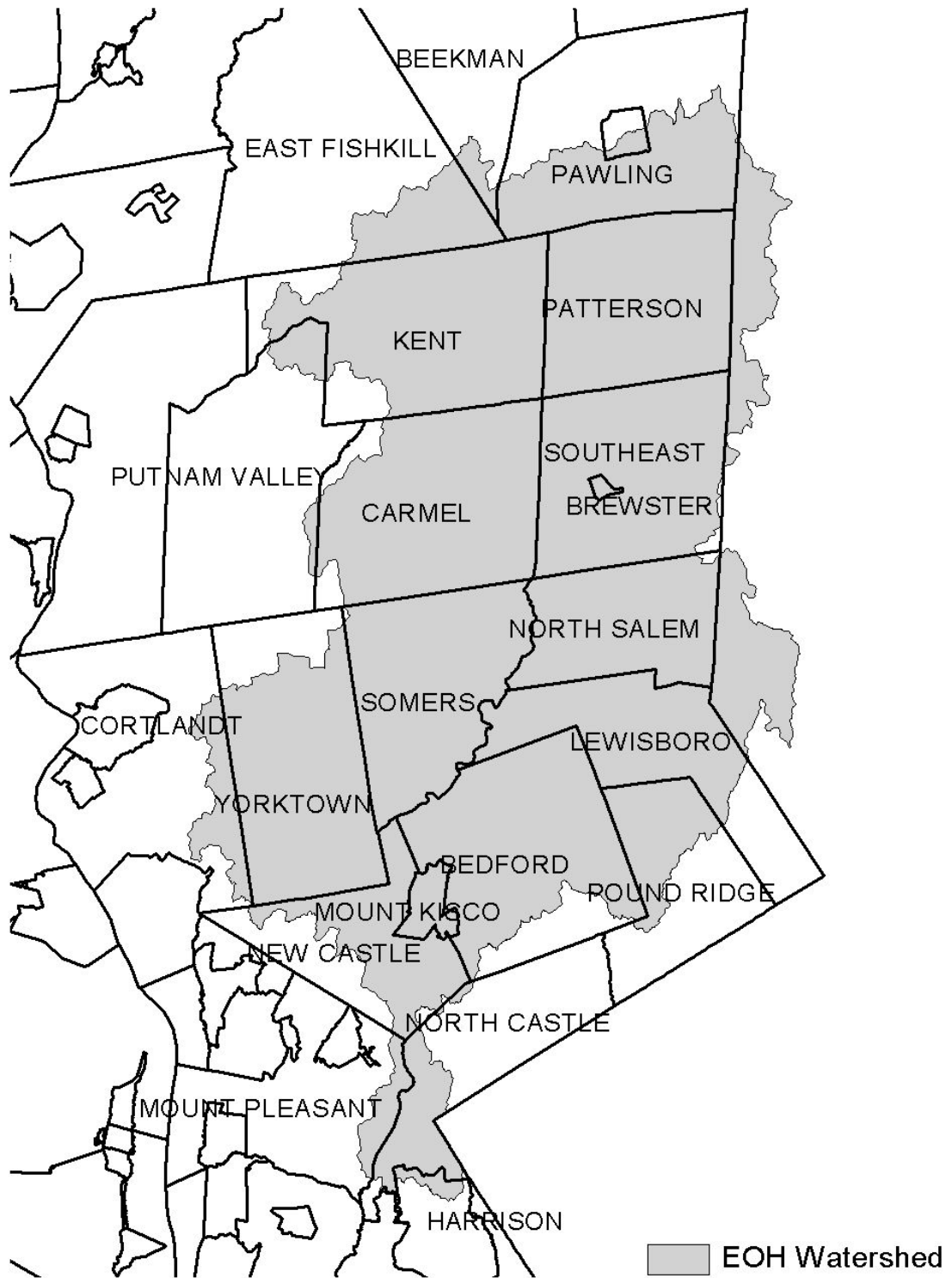

Figure 2 - Onondaga Lake Watershed



Figure 3 - Greenwood Lake Watershed

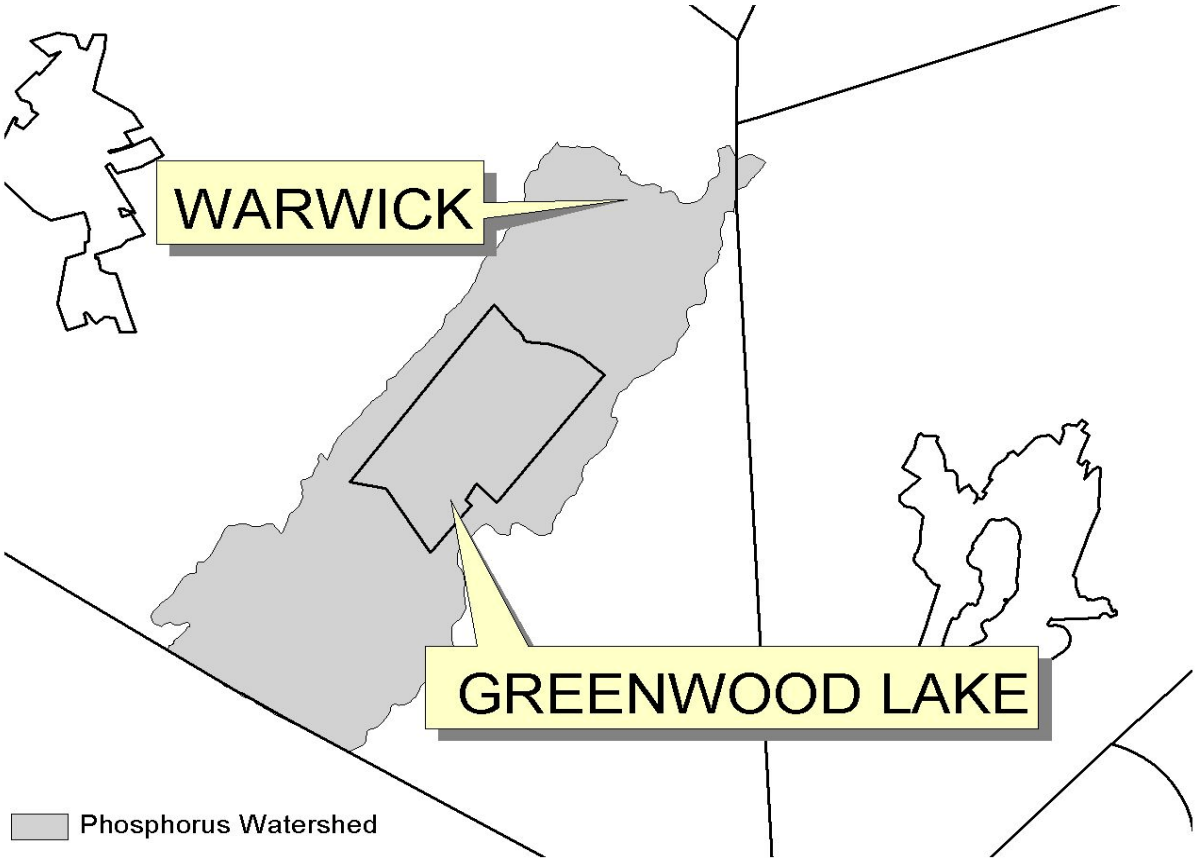

Figure 4 - Oscawana Lake Watershed

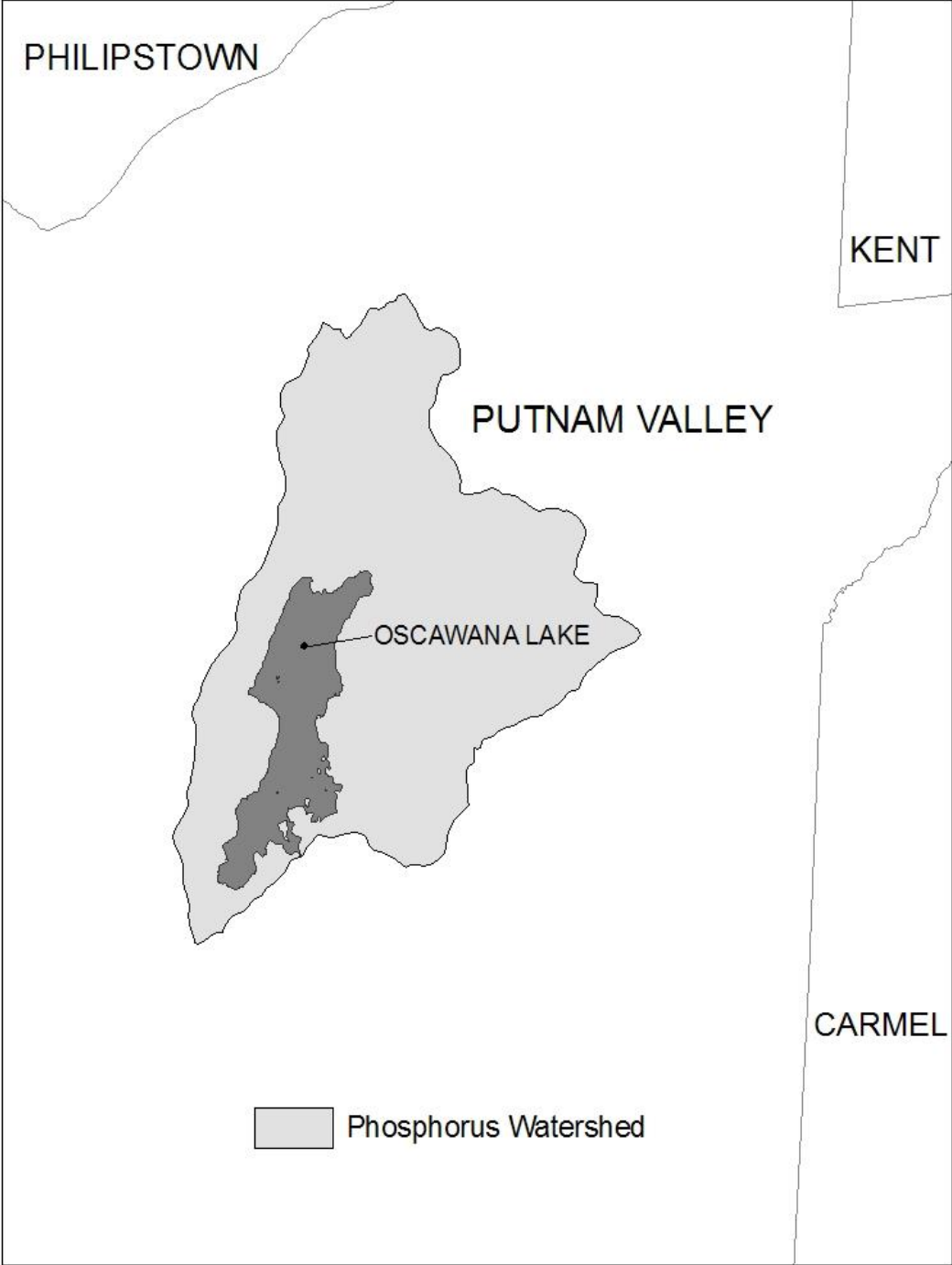
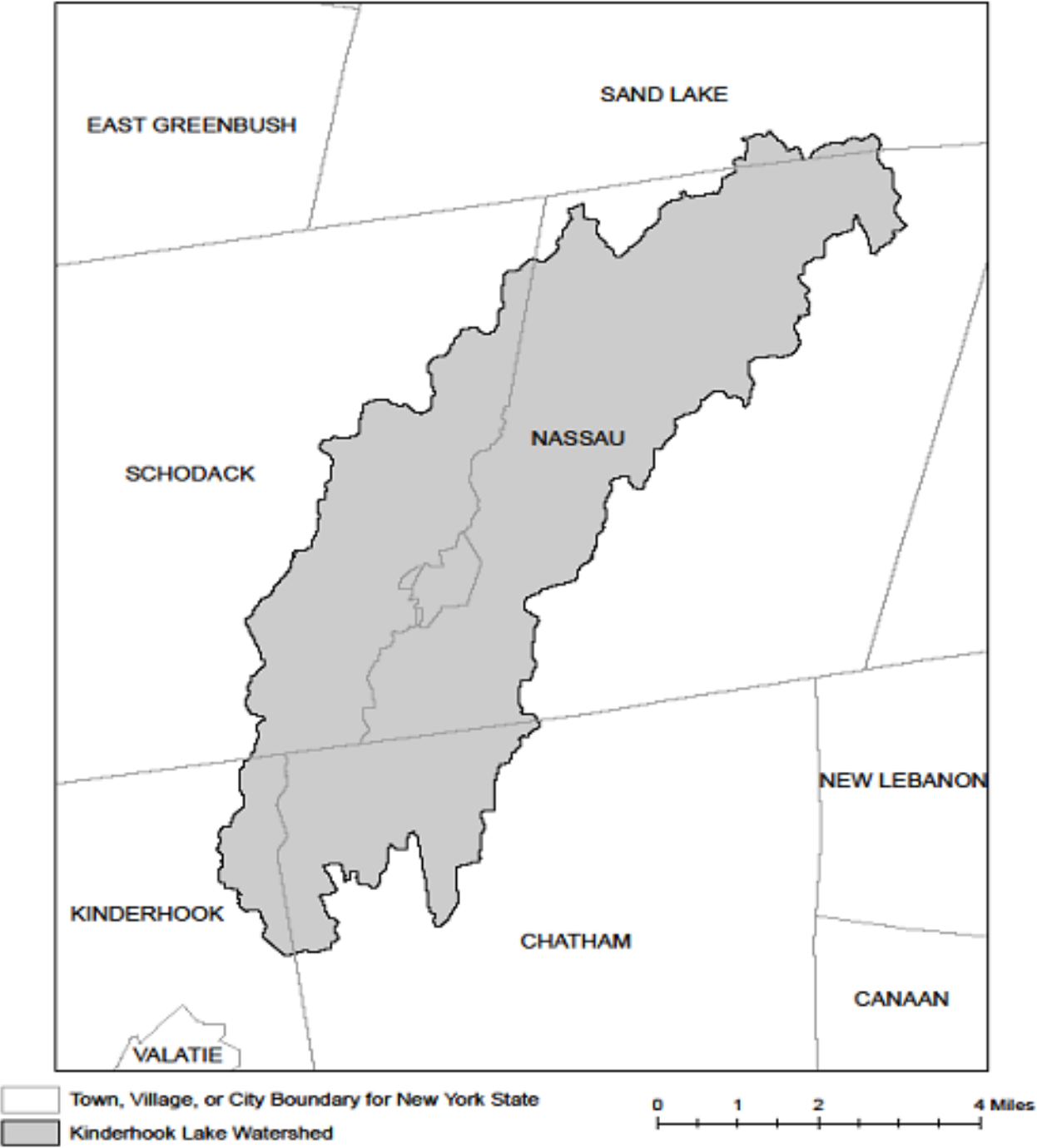

Figure 5 - Kinderhook Lake Watershed



APPENDIX D – Watersheds with Lower Disturbance Threshold

Watersheds where *owners or operators* of construction activities that involve soil disturbances between five thousand (5000) square feet and one (1) acre of land must obtain coverage under this permit.

Entire New York City Watershed that is located east of the Hudson River - See Figure 1 in Appendix C

APPENDIX E – 303(d) Segments Impaired by Construction Related Pollutant(s)

List of 303(d) segments impaired by pollutants related to *construction activity* (e.g. silt, sediment or nutrients). The list was developed using "The Final New York State 2016 Section 303(d) List of Impaired Waters Requiring a TMDL/Other Strategy" dated November 2016. *Owners or operators* of single family home and single family residential subdivisions with 25% or less total impervious cover at total site build-out that involve soil disturbances of one or more acres of land, but less than 5 acres, and *directly discharge* to one of the listed segments below shall prepare a SWPPP that includes post-construction stormwater management practices designed in conformance with the New York State Stormwater Management Design Manual ("Design Manual"), dated January 2015.

COUNTY	WATERBODY	POLLUTANT
Albany	Ann Lee (Shakers) Pond, Stump Pond	Nutrients
Albany	Basic Creek Reservoir	Nutrients
Allegany	Amity Lake, Saunders Pond	Nutrients
Bronx	Long Island Sound, Bronx	Nutrients
Bronx	Van Cortlandt Lake	Nutrients
Broome	Fly Pond, Deer Lake, Sky Lake	Nutrients
Broome	Minor Tribs to Lower Susquehanna (north)	Nutrients
Broome	Whitney Point Lake/Reservoir	Nutrients
Cattaraugus	Allegheny River/Reservoir	Nutrients
Cattaraugus	Beaver (Alma) Lake	Nutrients
Cattaraugus	Case Lake	Nutrients
Cattaraugus	Linlyco/Club Pond	Nutrients
Cayuga	Duck Lake	Nutrients
Cayuga	Little Sodus Bay	Nutrients
Chautauqua	Bear Lake	Nutrients
Chautauqua	Chadakoin River and tribs	Nutrients
Chautauqua	Chautauqua Lake, North	Nutrients
Chautauqua	Chautauqua Lake, South	Nutrients
Chautauqua	Findley Lake	Nutrients
Chautauqua	Hulburt/Clymer Pond	Nutrients
Clinton	Great Chazy River, Lower, Main Stem	Silt/Sediment
Clinton	Lake Champlain, Main Lake, Middle	Nutrients
Clinton	Lake Champlain, Main Lake, North	Nutrients
Columbia	Kinderhook Lake	Nutrients
Columbia	Robinson Pond	Nutrients
Cortland	Dean Pond	Nutrients

303(d) Segments Impaired by Construction Related Pollutant(s)

Dutchess	Fall Kill and tribs	Nutrients
Dutchess	Hillside Lake	Nutrients
Dutchess	Wappingers Lake	Nutrients
Dutchess	Wappingers Lake	Silt/Sediment
Erie	Beeman Creek and tribs	Nutrients
Erie	Ellicott Creek, Lower, and tribs	Silt/Sediment
Erie	Ellicott Creek, Lower, and tribs	Nutrients
Erie	Green Lake	Nutrients
Erie	Little Sister Creek, Lower, and tribs	Nutrients
Erie	Murder Creek, Lower, and tribs	Nutrients
Erie	Rush Creek and tribs	Nutrients
Erie	Scajaquada Creek, Lower, and tribs	Nutrients
Erie	Scajaquada Creek, Middle, and tribs	Nutrients
Erie	Scajaquada Creek, Upper, and tribs	Nutrients
Erie	South Branch Smoke Cr, Lower, and tribs	Silt/Sediment
Erie	South Branch Smoke Cr, Lower, and tribs	Nutrients
Essex	Lake Champlain, Main Lake, South	Nutrients
Essex	Lake Champlain, South Lake	Nutrients
Essex	Willsboro Bay	Nutrients
Genesee	Bigelow Creek and tribs	Nutrients
Genesee	Black Creek, Middle, and minor tribs	Nutrients
Genesee	Black Creek, Upper, and minor tribs	Nutrients
Genesee	Bowen Brook and tribs	Nutrients
Genesee	LeRoy Reservoir	Nutrients
Genesee	Oak Orchard Cr, Upper, and tribs	Nutrients
Genesee	Tonawanda Creek, Middle, Main Stem	Nutrients
Greene	Schoharie Reservoir	Silt/Sediment
Greene	Sleepy Hollow Lake	Silt/Sediment
Herkimer	Steele Creek tribs	Silt/Sediment
Herkimer	Steele Creek tribs	Nutrients
Jefferson	Moon Lake	Nutrients
Kings	Hendrix Creek	Nutrients
Kings	Prospect Park Lake	Nutrients
Lewis	Mill Creek/South Branch, and tribs	Nutrients
Livingston	Christie Creek and tribs	Nutrients
Livingston	Conesus Lake	Nutrients
Livingston	Mill Creek and minor tribs	Silt/Sediment
Monroe	Black Creek, Lower, and minor tribs	Nutrients
Monroe	Buck Pond	Nutrients
Monroe	Cranberry Pond	Nutrients

303(d) Segments Impaired by Construction Related Pollutant(s)

Monroe	Lake Ontario Shoreline, Western	Nutrients
Monroe	Long Pond	Nutrients
Monroe	Mill Creek and tribs	Nutrients
Monroe	Mill Creek/Blue Pond Outlet and tribs	Nutrients
Monroe	Minor Tribs to Irondequoit Bay	Nutrients
Monroe	Rochester Embayment - East	Nutrients
Monroe	Rochester Embayment - West	Nutrients
Monroe	Shipbuilders Creek and tribs	Nutrients
Monroe	Thomas Creek/White Brook and tribs	Nutrients
Nassau	Beaver Lake	Nutrients
Nassau	Camaans Pond	Nutrients
Nassau	East Meadow Brook, Upper, and tribs	Silt/Sediment
Nassau	East Rockaway Channel	Nutrients
Nassau	Grant Park Pond	Nutrients
Nassau	Hempstead Bay	Nutrients
Nassau	Hempstead Lake	Nutrients
Nassau	Hewlett Bay	Nutrients
Nassau	Hog Island Channel	Nutrients
Nassau	Long Island Sound, Nassau County Waters	Nutrients
Nassau	Massapequa Creek and tribs	Nutrients
Nassau	Milburn/Parsonage Creeks, Upp, and tribs	Nutrients
Nassau	Reynolds Channel, west	Nutrients
Nassau	Tidal Tribs to Hempstead Bay	Nutrients
Nassau	Tribs (fresh) to East Bay	Nutrients
Nassau	Tribs (fresh) to East Bay	Silt/Sediment
Nassau	Tribs to Smith/Halls Ponds	Nutrients
Nassau	Woodmere Channel	Nutrients
New York	Harlem Meer	Nutrients
New York	The Lake in Central Park	Nutrients
Niagara	Bergholtz Creek and tribs	Nutrients
Niagara	Hyde Park Lake	Nutrients
Niagara	Lake Ontario Shoreline, Western	Nutrients
Niagara	Lake Ontario Shoreline, Western	Nutrients
Oneida	Ballou, Nail Creeks and tribs	Nutrients
Onondaga	Harbor Brook, Lower, and tribs	Nutrients
Onondaga	Ley Creek and tribs	Nutrients
Onondaga	Minor Tribs to Onondaga Lake	Nutrients
Onondaga	Ninemile Creek, Lower, and tribs	Nutrients
Onondaga	Onondaga Creek, Lower, and tribs	Nutrients
Onondaga	Onondaga Creek, Middle, and tribs	Nutrients

303(d) Segments Impaired by Construction Related Pollutant(s)

Onondaga	Onondaga Lake, northern end	Nutrients
Onondaga	Onondaga Lake, southern end	Nutrients
Ontario	Great Brook and minor tribs	Silt/Sediment
Ontario	Great Brook and minor tribs	Nutrients
Ontario	Hemlock Lake Outlet and minor tribs	Nutrients
Ontario	Honeoye Lake	Nutrients
Orange	Greenwood Lake	Nutrients
Orange	Monhagen Brook and tribs	Nutrients
Orange	Orange Lake	Nutrients
Orleans	Lake Ontario Shoreline, Western	Nutrients
Orleans	Lake Ontario Shoreline, Western	Nutrients
Oswego	Lake Neatahwanta	Nutrients
Oswego	Pleasant Lake	Nutrients
Putnam	Bog Brook Reservoir	Nutrients
Putnam	Boyd Corners Reservoir	Nutrients
Putnam	Croton Falls Reservoir	Nutrients
Putnam	Diverting Reservoir	Nutrients
Putnam	East Branch Reservoir	Nutrients
Putnam	Lake Carmel	Nutrients
Putnam	Middle Branch Reservoir	Nutrients
Putnam	Oscawana Lake	Nutrients
Putnam	Palmer Lake	Nutrients
Putnam	West Branch Reservoir	Nutrients
Queens	Bergen Basin	Nutrients
Queens	Flushing Creek/Bay	Nutrients
Queens	Jamaica Bay, Eastern, and tribs (Queens)	Nutrients
Queens	Kissena Lake	Nutrients
Queens	Meadow Lake	Nutrients
Queens	Willow Lake	Nutrients
Rensselaer	Nassau Lake	Nutrients
Rensselaer	Snyders Lake	Nutrients
Richmond	Grasmere Lake/Bradys Pond	Nutrients
Rockland	Congers Lake, Swartout Lake	Nutrients
Rockland	Rockland Lake	Nutrients
Saratoga	Ballston Lake	Nutrients
Saratoga	Dwaas Kill and tribs	Silt/Sediment
Saratoga	Dwaas Kill and tribs	Nutrients
Saratoga	Lake Lonely	Nutrients
Saratoga	Round Lake	Nutrients
Saratoga	Tribs to Lake Lonely	Nutrients

303(d) Segments Impaired by Construction Related Pollutant(s)

Schenectady	Collins Lake	Nutrients
Schenectady	Duane Lake	Nutrients
Schenectady	Mariaville Lake	Nutrients
Schoharie	Engleville Pond	Nutrients
Schoharie	Summit Lake	Nutrients
Seneca	Reeder Creek and tribs	Nutrients
St.Lawrence	Black Lake Outlet/Black Lake	Nutrients
St.Lawrence	Fish Creek and minor tribs	Nutrients
Steuben	Smith Pond	Nutrients
Suffolk	Agawam Lake	Nutrients
Suffolk	Big/Little Fresh Ponds	Nutrients
Suffolk	Canaan Lake	Silt/Sediment
Suffolk	Canaan Lake	Nutrients
Suffolk	Flanders Bay, West/Lower Sawmill Creek	Nutrients
Suffolk	Fresh Pond	Nutrients
Suffolk	Great South Bay, East	Nutrients
Suffolk	Great South Bay, Middle	Nutrients
Suffolk	Great South Bay, West	Nutrients
Suffolk	Lake Ronkonkoma	Nutrients
Suffolk	Long Island Sound, Suffolk County, West	Nutrients
Suffolk	Mattituck (Marratooka) Pond	Nutrients
Suffolk	Meetinghouse/Terrys Creeks and tribs	Nutrients
Suffolk	Mill and Seven Ponds	Nutrients
Suffolk	Millers Pond	Nutrients
Suffolk	Moriches Bay, East	Nutrients
Suffolk	Moriches Bay, West	Nutrients
Suffolk	Peconic River, Lower, and tidal tribs	Nutrients
Suffolk	Quantuck Bay	Nutrients
Suffolk	Shinnecock Bay and Inlet	Nutrients
Suffolk	Tidal tribs to West Moriches Bay	Nutrients
Sullivan	Bodine, Montgomery Lakes	Nutrients
Sullivan	Davies Lake	Nutrients
Sullivan	Evens Lake	Nutrients
Sullivan	Pleasure Lake	Nutrients
Tompkins	Cayuga Lake, Southern End	Nutrients
Tompkins	Cayuga Lake, Southern End	Silt/Sediment
Tompkins	Owasco Inlet, Upper, and tribs	Nutrients
Ulster	Ashokan Reservoir	Silt/Sediment
Ulster	Esopus Creek, Upper, and minor tribs	Silt/Sediment
Warren	Hague Brook and tribs	Silt/Sediment

303(d) Segments Impaired by Construction Related Pollutant(s)

Warren	Huddle/Finkle Brooks and tribs	Silt/Sediment
Warren	Indian Brook and tribs	Silt/Sediment
Warren	Lake George	Silt/Sediment
Warren	Tribs to L.George, Village of L George	Silt/Sediment
Washington	Cossayuna Lake	Nutrients
Washington	Lake Champlain, South Bay	Nutrients
Washington	Tribs to L.George, East Shore	Silt/Sediment
Washington	Wood Cr/Champlain Canal and minor tribs	Nutrients
Wayne	Port Bay	Nutrients
Westchester	Amawalk Reservoir	Nutrients
Westchester	Blind Brook, Upper, and tribs	Silt/Sediment
Westchester	Cross River Reservoir	Nutrients
Westchester	Lake Katonah	Nutrients
Westchester	Lake Lincolndale	Nutrients
Westchester	Lake Meahagh	Nutrients
Westchester	Lake Mohegan	Nutrients
Westchester	Lake Shenorock	Nutrients
Westchester	Long Island Sound, Westchester (East)	Nutrients
Westchester	Mamaroneck River, Lower	Silt/Sediment
Westchester	Mamaroneck River, Upper, and minor tribs	Silt/Sediment
Westchester	Muscoot/Upper New Croton Reservoir	Nutrients
Westchester	New Croton Reservoir	Nutrients
Westchester	Peach Lake	Nutrients
Westchester	Reservoir No.1 (Lake Isle)	Nutrients
Westchester	Saw Mill River, Lower, and tribs	Nutrients
Westchester	Saw Mill River, Middle, and tribs	Nutrients
Westchester	Sheldrake River and tribs	Silt/Sediment
Westchester	Sheldrake River and tribs	Nutrients
Westchester	Silver Lake	Nutrients
Westchester	Teatown Lake	Nutrients
Westchester	Titicus Reservoir	Nutrients
Westchester	Truesdale Lake	Nutrients
Westchester	Wallace Pond	Nutrients
Wyoming	Java Lake	Nutrients
Wyoming	Silver Lake	Nutrients

APPENDIX F – List of NYS DEC Regional Offices

<u>Region</u>	<u>COVERING THE FOLLOWING COUNTIES:</u>	<u>DIVISION OF ENVIRONMENTAL PERMITS (DEP) PERMIT ADMINISTRATORS</u>	<u>DIVISION OF WATER (DOW) WATER (SPDES) PROGRAM</u>
1	NASSAU AND SUFFOLK	50 CIRCLE ROAD STONY BROOK, NY 11790 TEL. (631) 444-0365	50 CIRCLE ROAD STONY BROOK, NY 11790-3409 TEL. (631) 444-0405
2	BRONX, KINGS, NEW YORK, QUEENS AND RICHMOND	1 HUNTERS POINT PLAZA, 47-40 21ST ST. LONG ISLAND CITY, NY 11101-5407 TEL. (718) 482-4997	1 HUNTERS POINT PLAZA, 47-40 21ST ST. LONG ISLAND CITY, NY 11101-5407 TEL. (718) 482-4933
3	DUTCHESS, ORANGE, PUTNAM, ROCKLAND, SULLIVAN, ULSTER AND WESTCHESTER	21 SOUTH PUTT CORNERS ROAD NEW PALTZ, NY 12561-1696 TEL. (845) 256-3059	100 HILLSIDE AVENUE, SUITE 1W WHITE PLAINS, NY 10603 TEL. (914) 428 - 2505
4	ALBANY, COLUMBIA, DELAWARE, GREENE, MONTGOMERY, OTSEGO, RENSSELAER, SCHENECTADY AND SCHOHARIE	1150 NORTH WESTCOTT ROAD SCHENECTADY, NY 12306-2014 TEL. (518) 357-2069	1130 NORTH WESTCOTT ROAD SCHENECTADY, NY 12306-2014 TEL. (518) 357-2045
5	CLINTON, ESSEX, FRANKLIN, FULTON, HAMILTON, SARATOGA, WARREN AND WASHINGTON	1115 STATE ROUTE 86, Po Box 296 RAY BROOK, NY 12977-0296 TEL. (518) 897-1234	232 GOLF COURSE ROAD WARRENSBURG, NY 12885-1172 TEL. (518) 623-1200
6	HERKIMER, JEFFERSON, LEWIS, ONEIDA AND ST. LAWRENCE	STATE OFFICE BUILDING 317 WASHINGTON STREET WATERTOWN, NY 13601-3787 TEL. (315) 785-2245	STATE OFFICE BUILDING 207 GENESEE STREET UTICA, NY 13501-2885 TEL. (315) 793-2554
7	BROOME, CAYUGA, CHENANGO, CORTLAND, MADISON, ONONDAGA, OSWEGO, TIOGA AND TOMPKINS	615 ERIE BLVD. WEST SYRACUSE, NY 13204-2400 TEL. (315) 426-7438	615 ERIE BLVD. WEST SYRACUSE, NY 13204-2400 TEL. (315) 426-7500
8	CHEMUNG, GENESEE, LIVINGSTON, MONROE, ONTARIO, ORLEANS, SCHUYLER, SENECA, STEUBEN, WAYNE AND YATES	6274 EAST AVON-LIMA ROADAVON, NY 14414-9519 TEL. (585) 226-2466	6274 EAST AVON-LIMA RD. AVON, NY 14414-9519 TEL. (585) 226-2466
9	ALLEGANY, CATTARAUGUS, CHAUTAUQUA, ERIE, NIAGARA AND WYOMING	270 MICHIGAN AVENUE BUFFALO, NY 14203-2999 TEL. (716) 851-7165	270 MICHIGAN AVENUE BUFFALO, NY 14203-2999 TEL. (716) 851-7070

Appendix C – Construction Personnel Contact List

- Construction Contact List -
- Contractor Certification Form -

Appendix C – Construction Contact List

Appendix C – Contractor Certification Form

Contractor Certification Form

**Stormwater Pollution Prevention Plan (SWPPP)
State Pollutant Discharge Elimination System (SPDES) General Permit for
Stormwater Discharges from Construction Activity
GP-0-20-001**

Watkins Glen Solar Energy Center
Town of Dix, Schuyler County, NY

All Contractors and Subcontractors performing construction activities shall sign the following certification before they commence construction activities. A copy of the certification shall be included in Appendix A of the on-site SWPPP. All Contractors and Subcontractors must identify at least one trained person from their company, who has met the requirements of a *Trained Contractor* as defined in GP-0-20-001, that will be responsible for the implementation of the SWPPP.

“I hereby certify under penalty of the law that I understand and agree to comply with the terms and conditions of the SWPPP and agree to implement any corrective actions identified by the Qualified Inspector during a site inspection. I also understand that the Owner or Operator must comply with the terms and conditions of the most current version of the New York State SPDES General Permit for Stormwater Discharges from Construction Activities (GP-0-20-001) and that it is unlawful for any person to cause or contribute to a violation of water quality standards. Furthermore, I am aware that there are significant penalties for submitting false information that I do not believe to be true, including the possibility of fine and imprisonment for knowing violations.”

Name of Construction Company

Address of Construction Company	Telephone Number
---------------------------------	------------------

Printed Name of Authorized Representative	Title
---	-------

Signature of Authorized Representative	Date
--	------

Printed Name of Trained Contractor(s)	Title(s)
---------------------------------------	----------

Type of construction services to be provided:

Appendix D – Agency Correspondence and Notifications

- NYSDEC Solar Panel Construction Stormwater Permitting/SWPPP Guidance
Memorandum -
- Maryland Department of the Environment (MDEP) Stormwater Design Guidance – Solar
Panel Installation -

Agency correspondence and notifications will be included with the Final SWPPP.

**Appendix D – NYSDEC Solar Panel Construction Stormwater
Permitting/SWPPP Guidance Memorandum**

NEW YORK STATE DEPARTMENT OF ENVIRONMENTAL CONSERVATION

Division of Water, Bureau of Water Permits
625 Broadway, Albany, New York 12233-3505
P: (518) 402-8111 | F: (518) 402-9029
www.dec.ny.gov

MEMORANDUM

TO: Regional Water Engineers

FROM: Robert Wither, Chief, South Permit Section 

SUBJECT: Solar Panel Construction Stormwater Permitting/SWPPP Guidance

DATE: April 6, 2018

Issue

The Department is seeing an increase in the number of solar panel construction projects across New York State. This has resulted in an increase in the number of questions on Construction General Permit (CGP) and Stormwater Pollution Prevention Plan (SWPPP) requirements from design professionals because the current CGP (GP-0-15-002) does not include a specific reference to the SWPPP requirements for solar panel projects in Tables 1 and 2 of Appendix B. To address this issue, the Division of Water (DOW) has developed the following guidance on CGP/SWPPP requirements for the different types of solar panel projects.

Scenario 1

The DOW considers solar panel projects designed and constructed in accordance with the following criteria to be a "*Land clearing and grading for the purposes of creating vegetated open space (i.e. recreational parks, lawns, meadows, fields)*" type project as listed in Table 1, Appendix B of the CGP. Therefore, the SWPPP for this type of project will typically just need to address erosion and sediment controls.

1. Solar panels are constructed on post or rack systems and elevated off the ground surface,
2. The panels are spaced apart so that rain water can flow off the down gradient side of the panel and continue as sheet flow across the ground surface*,
3. For solar panels constructed on slopes, the individual rows of solar panels are generally installed along the contour so rain water sheet flows down slope*,
4. The ground surface below the panels consist of a well-established vegetative cover (see "Final Stabilization" definition in Appendix A of the CGP),
5. The project does not include the construction of any traditional impervious areas (i.e. buildings, substation pads, gravel access roads or parking areas, etc.),
6. Construction of the solar panels will not alter the hydrology from pre-to post development conditions (see Appendix A of the CGP, for definition of "Alter the hydrology..."). Note: The design professional shall perform the necessary site assessment/hydrology analysis to make this determination.



*Refer to Maryland's "Stormwater Design Guidance- Solar Panel Installations" attached for guidance on panel installation.

**See notes below for additional criteria.

Scenario 2

If the design and construction of the solar panels meets all the criteria above, except for item 6, the project will fall under the "*All other construction activities that include the construction or reconstruction of impervious area or alter the hydrology from pre-to post development conditions, and are not listed in Table 1*" project type as listed in Table 2, Appendix B of the CGP. Therefore, the SWPPP for this type of project must address post-construction stormwater practices designed in accordance with the sizing criteria in Chapter 4 of the NYS Stormwater Management Design Manual, dated January 2015 (Note: Chapter 10 for projects in NYC EOH Watershed). The Water Quality Volume (WQv)/Runoff Reduction Volume (RRv) sizing criteria can be addressed by designing and constructing the solar panels in accordance with the criteria in items 1 – 4 above, however, the quantity control sizing criteria (Cpv, Qp and Qf) from Chapter 4 (or 10) of the Design Manual must still be addressed, unless one of the waiver criteria from Chapter 4 can be applied. **See notes below for additional criteria.

**** Notes**

- **Item 1:** For solar panel projects where the panels are mounted directly to the ground (i.e. no space below panel to allow for infiltration of runoff), the SWPPP must address post-construction stormwater management controls designed in accordance with the sizing criteria in Chapter 4 of the NYS Stormwater Management Design Manual, dated January 2015 (Note: Chapter 10 for projects in NYC EOH Watershed).

- **Item 5:** For solar panel projects that include the construction of traditional impervious areas (i.e. buildings, substation pads, gravel access roads or parking areas, etc.), the SWPPP must address post-construction stormwater management controls for those areas of the project. This applies to both Scenario 1 and 2 above.

cc: Carol Lamb-Lafay, BWP
Dave Gasper, BWP

**Appendix D – Maryland Department of the Environment (MDEP)
Stormwater Design Guidance – Solar Panel Installation**



Stormwater Design Guidance – Solar Panel Installations

Revisions to Maryland's stormwater management regulations in 2010 require that environmental site design (ESD) be used to the maximum extent practicable (MEP) to mimic natural hydrology, reduce runoff to reflect forested wooded conditions, and minimize the impact of land development on water resources. This applies to any residential, commercial, industrial, or institutional development where more than 5,000 square feet of land area is disturbed. Consequently, stormwater management must be addressed even when permeable features like solar panel installations exceed 5,000 square feet of land disturbance.

Depending on local soil conditions and proposed imperviousness, the amount of rainfall that stormwater requirements are based on varies from 1.0 to 2.6 inches. However, addressing stormwater management does not mean that structural or micro-scale practices must be constructed to capture and treat large volumes of runoff. Using nonstructural techniques like disconnecting impervious cover reduces runoff by promoting overland filtering and infiltration. Commonly used with smaller or narrower impervious areas like driveways or open roads, the Disconnection of Non-Rooftop Runoff technique (see pp. 5.61 to 5.65 of the **2000 Maryland Stormwater Design Manual**¹) is a low cost alternative for treating runoff in situations like rows of solar panels.

When non-rooftop disconnection is used to treat runoff, the following factors should be considered:

- The vegetated area receiving runoff must be equal to or greater in length than the disconnected surface (e.g., width of the row of solar panels)
- Runoff must sheet flow onto and across vegetated areas to maintain the disconnection
- Disconnections should be located on gradual slopes ($\leq 5\%$) to maintain sheetflow. Level spreaders, terraces, or berms may be used to maintain sheetflow conditions if the average slope is steeper than 5%. However, installations on slopes greater than 10% will require an engineered plan that ensures adequate treatment and the safe and non-erosive conveyance of runoff to the property line or downstream stormwater management practice.
- Disconnecting impervious surfaces works best in undisturbed soils. To minimize disturbance and compaction, construction vehicles and equipment should avoid areas used for disconnection during installation of the solar panels.
- Groundcover vegetation must be maintained in good condition in those areas receiving disconnected runoff. Typically this maintenance is no different than other lawn or landscaped areas. However, areas receiving runoff should be protected (e.g., planting shrubs or trees along the perimeter) from future compaction.

Depending on the layout and number of panels installed, the disconnection of non-rooftop runoff technique may address some or all of the stormwater management requirements for an individual project. Where the imperviousness is high or there is other infrastructure (e.g., access roads, transformers), additional runoff may need to be treated. In these situations, other ESD techniques or micro-scale practices may be needed to provide stormwater management for these features.

Example 1 – Using Non-Rooftop Disconnection Where the Average Slope $\leq 5\%$

Several rows of solar panels will be installed in an existing meadow. The soils within the meadow are hydrologic soil group (HSG) B and the average slope does not exceed 5%. Each row of panels is 10 feet wide and the distance between rows is 20 feet. The rows of solar panels will be installed according to Figure 1 below. In this scenario, the disconnection length is the same as the distance between rows (20 feet) and is greater than the width of each row (10 feet). Therefore, each row of panels is adequately disconnected and the runoff from 1.0 inch of rainfall is treated.

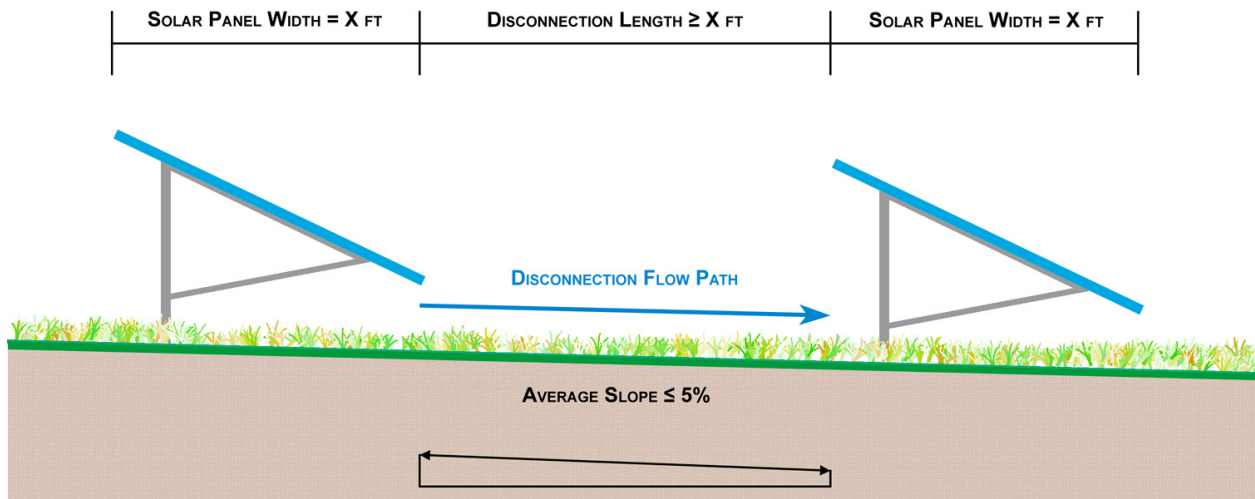

Figure 1. Typical Installation - Slope $\leq 5\%$

Example 2 – Using Non-Rooftop Disconnection Where the Average Slope $\geq 5\%$ but $\leq 10\%$

Several rows of solar panels will be installed in an existing meadow. The soils within the meadow are hydrologic soil group (HSG) B and the average slope is greater than 5% but less than 10%. Each row of panels is 10 feet wide and the distance between rows is 20 feet. The rows of solar panels will be installed as shown in Figure 2 below. The disconnection length is the same as the distance between rows (20 feet) and is greater than the width of each row (10 feet). However, in this example, a level spreader (typically 1 to 2-foot wide and 1 foot deep) has been located at the drip edge of each row of panels to dissipate energy and maintain sheetflow.

Discussion

To meet State and local stormwater management requirements, ESD must be used to the MEP to reduce runoff to reflect forested conditions. While all reasonable options for implementing ESD must be investigated, minimally, the runoff from 1 inch of rainfall must be treated. In each of the examples above, there may be additional opportunities to implement ESD techniques or practices and reduce runoff that should be explored. However, simply disconnecting the runoff from the solar panel arrays captures and treats the runoff from 1.0 inch of rainfall. Where imperviousness is low and soil conditions less optimal (e.g., HSG C or D), this may be sufficient to completely address stormwater management requirements. In more dense applications or in sandy soils, additional stormwater management may be required.

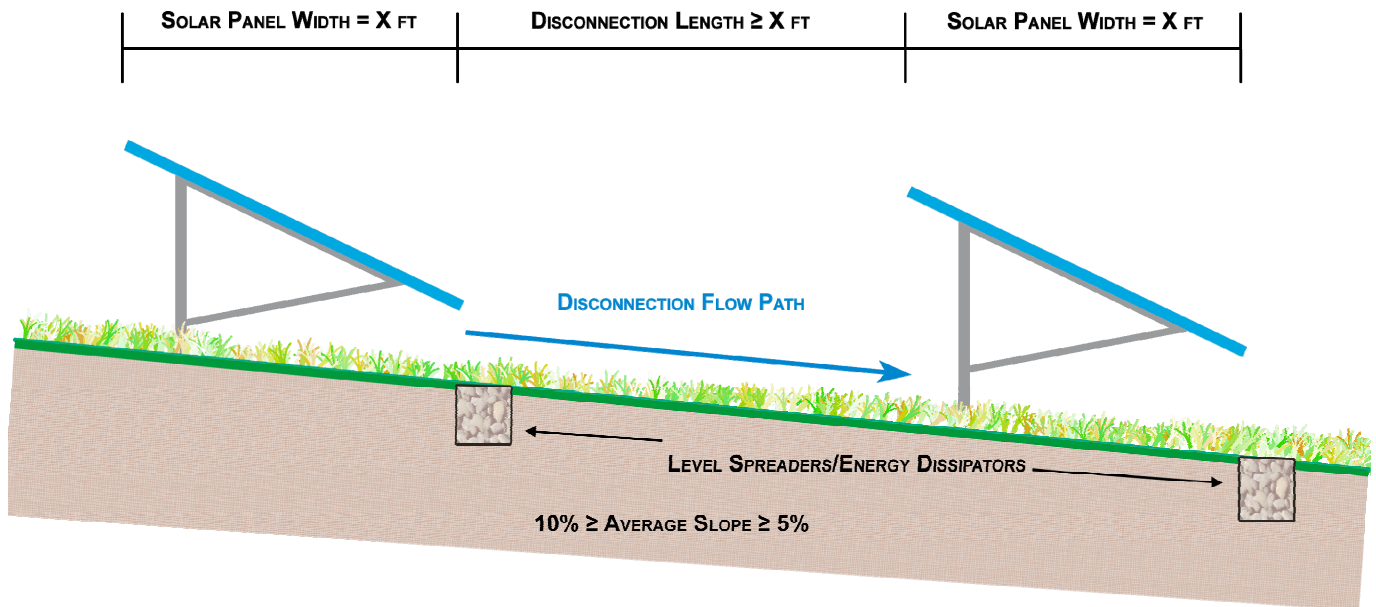

Figure 2. Typical Installation – Slope $\geq 5\%$ but $\leq 10\%$

Conclusion

The primary purpose of Maryland's stormwater management program is to mimic natural hydrologic runoff characteristics and minimize the impact of land development on water resources. Any land development project that exceeds 5,000 square feet of disturbance, including solar panel projects, must address stormwater management. However, for solar panels, stormwater management may be provided in a cost-effective manner by disconnecting each row of panels and directing runoff over the vegetated areas between the individual rows.

Resources

¹ [2000 Maryland Stormwater Design Manual, Volumes I and II](http://www.mde.state.md.us/programs/Water/StormwaterManagementProgram/MarylandStormwaterDesignManual/Pages/Programs/WaterPrograms/SedimentandStormwater/stormwater_design/index.aspx), MDE, October 2000
 (http://www.mde.state.md.us/programs/Water/StormwaterManagementProgram/MarylandStormwaterDesignManual/Pages/Programs/WaterPrograms/SedimentandStormwater/stormwater_design/index.aspx)

Appendix E – Environmental Background Information

- Environmental and Cultural Resource Information -
- USDA NRCS Soil Resource Report -

Appendix E – Environmental and Cultural Resource Information

Environmental and cultural resource information will be included with the Final SWPPP.

Refer to Exhibits 20, 22, and 23 of the Article 10 Application for detailed discussion on environmental and cultural resources at the Project.

Appendix E – USDA NRCS Soil Resource Report



United States
Department of
Agriculture

NRCS

Natural
Resources
Conservation
Service

A product of the National
Cooperative Soil Survey,
a joint effort of the United
States Department of
Agriculture and other
Federal agencies, State
agencies including the
Agricultural Experiment
Stations, and local
participants

Custom Soil Resource Report for **Schuyler County, New York**

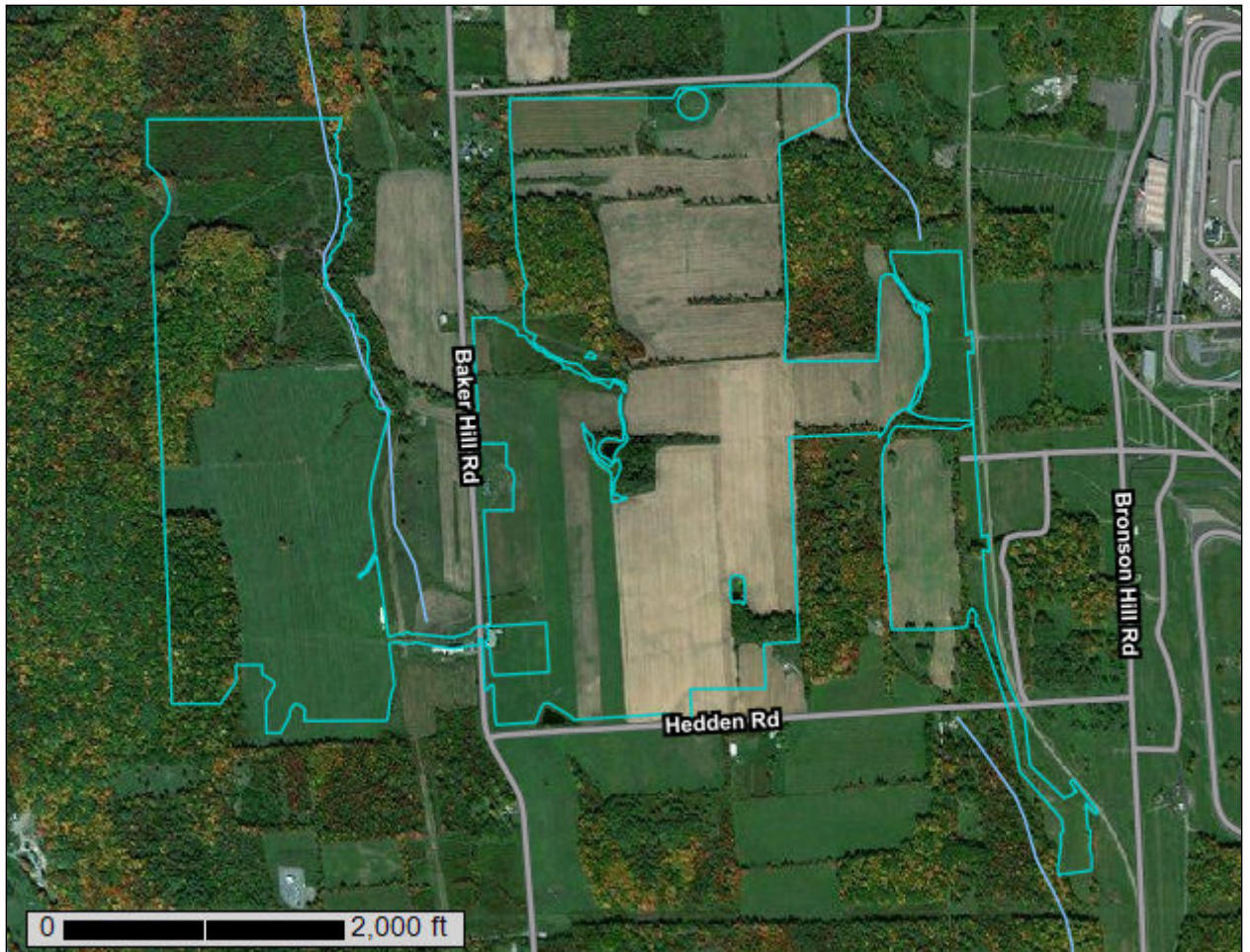

Preface

Soil surveys contain information that affects land use planning in survey areas. They highlight soil limitations that affect various land uses and provide information about the properties of the soils in the survey areas. Soil surveys are designed for many different users, including farmers, ranchers, foresters, agronomists, urban planners, community officials, engineers, developers, builders, and home buyers. Also, conservationists, teachers, students, and specialists in recreation, waste disposal, and pollution control can use the surveys to help them understand, protect, or enhance the environment.

Various land use regulations of Federal, State, and local governments may impose special restrictions on land use or land treatment. Soil surveys identify soil properties that are used in making various land use or land treatment decisions. The information is intended to help the land users identify and reduce the effects of soil limitations on various land uses. The landowner or user is responsible for identifying and complying with existing laws and regulations.

Although soil survey information can be used for general farm, local, and wider area planning, onsite investigation is needed to supplement this information in some cases. Examples include soil quality assessments (<http://www.nrcs.usda.gov/wps/portal/nrcs/main/soils/health/>) and certain conservation and engineering applications. For more detailed information, contact your local USDA Service Center (<https://offices.sc.egov.usda.gov/locator/app?agency=nrcs>) or your NRCS State Soil Scientist (http://www.nrcs.usda.gov/wps/portal/nrcs/detail/soils/contactus/?cid=nrcs142p2_053951).

Great differences in soil properties can occur within short distances. Some soils are seasonally wet or subject to flooding. Some are too unstable to be used as a foundation for buildings or roads. Clayey or wet soils are poorly suited to use as septic tank absorption fields. A high water table makes a soil poorly suited to basements or underground installations.

The National Cooperative Soil Survey is a joint effort of the United States Department of Agriculture and other Federal agencies, State agencies including the Agricultural Experiment Stations, and local agencies. The Natural Resources Conservation Service (NRCS) has leadership for the Federal part of the National Cooperative Soil Survey.

Information about soils is updated periodically. Updated information is available through the NRCS Web Soil Survey, the site for official soil survey information.

The U.S. Department of Agriculture (USDA) prohibits discrimination in all its programs and activities on the basis of race, color, national origin, age, disability, and where applicable, sex, marital status, familial status, parental status, religion, sexual orientation, genetic information, political beliefs, reprisal, or because all or a part of an individual's income is derived from any public assistance program. (Not all prohibited bases apply to all programs.) Persons with disabilities who require

alternative means for communication of program information (Braille, large print, audiotape, etc.) should contact USDA's TARGET Center at (202) 720-2600 (voice and TDD). To file a complaint of discrimination, write to USDA, Director, Office of Civil Rights, 1400 Independence Avenue, S.W., Washington, D.C. 20250-9410 or call (800) 795-3272 (voice) or (202) 720-6382 (TDD). USDA is an equal opportunity provider and employer.

Contents

Preface	2
How Soil Surveys Are Made	5
Soil Map	8
Soil Map.....	9
Legend.....	10
Map Unit Legend.....	11
Map Unit Descriptions.....	11
Schuyler County, New York.....	14
Cp—Chippewa silt loam, 0 to 3 percent slopes.....	14
FrB—Fremont silt loam, 3 to 8 percent slopes.....	15
LoC—Lordstown channery silt loam, 8 to 15 percent slopes.....	17
MrB—Mardin channery silt loam, 3 to 8 percent slopes.....	18
MrC—Mardin channery silt loam, 8 to 15 percent slopes.....	20
MrD—Mardin channery silt loam, 15 to 25 percent slopes.....	21
TuB—Tuller channery silt loam, 3 to 8 percent slopes.....	23
TuC—Tuller channery silt loam, 8 to 15 percent slopes.....	24
VaB—Valois gravelly silt loam, 3 to 8 percent slopes.....	25
VaD—Valois gravelly silt loam, 15 to 25 percent slopes.....	27
VoB—Volusia channery silt loam, 3 to 8 percent slopes.....	28
VoC—Volusia channery silt loam, 8 to 15 percent slopes.....	29
VoD—Volusia channery silt loam, 15 to 25 percent slopes.....	31
References	33

How Soil Surveys Are Made

Soil surveys are made to provide information about the soils and miscellaneous areas in a specific area. They include a description of the soils and miscellaneous areas and their location on the landscape and tables that show soil properties and limitations affecting various uses. Soil scientists observed the steepness, length, and shape of the slopes; the general pattern of drainage; the kinds of crops and native plants; and the kinds of bedrock. They observed and described many soil profiles. A soil profile is the sequence of natural layers, or horizons, in a soil. The profile extends from the surface down into the unconsolidated material in which the soil formed or from the surface down to bedrock. The unconsolidated material is devoid of roots and other living organisms and has not been changed by other biological activity.

Currently, soils are mapped according to the boundaries of major land resource areas (MLRAs). MLRAs are geographically associated land resource units that share common characteristics related to physiography, geology, climate, water resources, soils, biological resources, and land uses (USDA, 2006). Soil survey areas typically consist of parts of one or more MLRA.

The soils and miscellaneous areas in a survey area occur in an orderly pattern that is related to the geology, landforms, relief, climate, and natural vegetation of the area. Each kind of soil and miscellaneous area is associated with a particular kind of landform or with a segment of the landform. By observing the soils and miscellaneous areas in the survey area and relating their position to specific segments of the landform, a soil scientist develops a concept, or model, of how they were formed. Thus, during mapping, this model enables the soil scientist to predict with a considerable degree of accuracy the kind of soil or miscellaneous area at a specific location on the landscape.

Commonly, individual soils on the landscape merge into one another as their characteristics gradually change. To construct an accurate soil map, however, soil scientists must determine the boundaries between the soils. They can observe only a limited number of soil profiles. Nevertheless, these observations, supplemented by an understanding of the soil-vegetation-landscape relationship, are sufficient to verify predictions of the kinds of soil in an area and to determine the boundaries.

Soil scientists recorded the characteristics of the soil profiles that they studied. They noted soil color, texture, size and shape of soil aggregates, kind and amount of rock fragments, distribution of plant roots, reaction, and other features that enable them to identify soils. After describing the soils in the survey area and determining their properties, the soil scientists assigned the soils to taxonomic classes (units). Taxonomic classes are concepts. Each taxonomic class has a set of soil characteristics with precisely defined limits. The classes are used as a basis for comparison to classify soils systematically. Soil taxonomy, the system of taxonomic classification used in the United States, is based mainly on the kind and character of soil properties and the arrangement of horizons within the profile. After the soil

Custom Soil Resource Report

scientists classified and named the soils in the survey area, they compared the individual soils with similar soils in the same taxonomic class in other areas so that they could confirm data and assemble additional data based on experience and research.

The objective of soil mapping is not to delineate pure map unit components; the objective is to separate the landscape into landforms or landform segments that have similar use and management requirements. Each map unit is defined by a unique combination of soil components and/or miscellaneous areas in predictable proportions. Some components may be highly contrasting to the other components of the map unit. The presence of minor components in a map unit in no way diminishes the usefulness or accuracy of the data. The delineation of such landforms and landform segments on the map provides sufficient information for the development of resource plans. If intensive use of small areas is planned, onsite investigation is needed to define and locate the soils and miscellaneous areas.

Soil scientists make many field observations in the process of producing a soil map. The frequency of observation is dependent upon several factors, including scale of mapping, intensity of mapping, design of map units, complexity of the landscape, and experience of the soil scientist. Observations are made to test and refine the soil-landscape model and predictions and to verify the classification of the soils at specific locations. Once the soil-landscape model is refined, a significantly smaller number of measurements of individual soil properties are made and recorded. These measurements may include field measurements, such as those for color, depth to bedrock, and texture, and laboratory measurements, such as those for content of sand, silt, clay, salt, and other components. Properties of each soil typically vary from one point to another across the landscape.

Observations for map unit components are aggregated to develop ranges of characteristics for the components. The aggregated values are presented. Direct measurements do not exist for every property presented for every map unit component. Values for some properties are estimated from combinations of other properties.

While a soil survey is in progress, samples of some of the soils in the area generally are collected for laboratory analyses and for engineering tests. Soil scientists interpret the data from these analyses and tests as well as the field-observed characteristics and the soil properties to determine the expected behavior of the soils under different uses. Interpretations for all of the soils are field tested through observation of the soils in different uses and under different levels of management. Some interpretations are modified to fit local conditions, and some new interpretations are developed to meet local needs. Data are assembled from other sources, such as research information, production records, and field experience of specialists. For example, data on crop yields under defined levels of management are assembled from farm records and from field or plot experiments on the same kinds of soil.

Predictions about soil behavior are based not only on soil properties but also on such variables as climate and biological activity. Soil conditions are predictable over long periods of time, but they are not predictable from year to year. For example, soil scientists can predict with a fairly high degree of accuracy that a given soil will have a high water table within certain depths in most years, but they cannot predict that a high water table will always be at a specific level in the soil on a specific date.

After soil scientists located and identified the significant natural bodies of soil in the survey area, they drew the boundaries of these bodies on aerial photographs and

Custom Soil Resource Report

identified each as a specific map unit. Aerial photographs show trees, buildings, fields, roads, and rivers, all of which help in locating boundaries accurately.

Soil Map

The soil map section includes the soil map for the defined area of interest, a list of soil map units on the map and extent of each map unit, and cartographic symbols displayed on the map. Also presented are various metadata about data used to produce the map, and a description of each soil map unit.

Custom Soil Resource Report Soil Map



Map Scale: 1:14,500 if printed on A landscape (11" x 8.5") sheet.

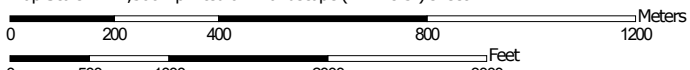

Map projection: Web Mercator Corner coordinates: WGS84 Edge tics: UTM Zone 18N WGS84

MAP LEGEND

Area of Interest (AOI)

 Area of Interest (AOI)

Soils







 Soil Map Unit Polygons

 Soil Map Unit Lines

 Soil Map Unit Points

Special Point Features





-  Blowout
-  Borrow Pit
-  Clay Spot
-  Closed Depression
-  Gravel Pit
-  Gravelly Spot
-  Landfill
-  Lava Flow
-  Marsh or swamp
-  Mine or Quarry
-  Miscellaneous Water
-  Perennial Water
-  Rock Outcrop
-  Saline Spot
-  Sandy Spot
-  Severely Eroded Spot
-  Sinkhole
-  Slide or Slip
-  Sodic Spot

-  Spoil Area
-  Stony Spot
-  Very Stony Spot
-  Wet Spot
-  Other
-  Special Line Features

Water Features

 Streams and Canals

Transportation

-  Rails
-  Interstate Highways
-  US Routes
-  Major Roads
-  Local Roads

Background

 Aerial Photography

MAP INFORMATION

The soil surveys that comprise your AOI were mapped at 1:15,800.

Please rely on the bar scale on each map sheet for map measurements.

Source of Map: Natural Resources Conservation Service
 Web Soil Survey URL:
 Coordinate System: Web Mercator (EPSG:3857)

Maps from the Web Soil Survey are based on the Web Mercator projection, which preserves direction and shape but distorts distance and area. A projection that preserves area, such as the Albers equal-area conic projection, should be used if more accurate calculations of distance or area are required.

This product is generated from the USDA-NRCS certified data as of the version date(s) listed below.

Soil Survey Area: Schuyler County, New York
 Survey Area Data: Version 17, Jun 11, 2020

Soil map units are labeled (as space allows) for map scales 1:50,000 or larger.

Date(s) aerial images were photographed: Jul 10, 2014—Oct 30, 2016

The orthophoto or other base map on which the soil lines were compiled and digitized probably differs from the background imagery displayed on these maps. As a result, some minor shifting of map unit boundaries may be evident.

Map Unit Legend

Map Unit Symbol	Map Unit Name	Acres in AOI	Percent of AOI
Cp	Chippewa silt loam, 0 to 3 percent slopes	1.9	0.5%
FrB	Fremont silt loam, 3 to 8 percent slopes	0.0	0.0%
LoC	Lordstown channery silt loam, 8 to 15 percent slopes	16.8	4.3%
MrB	Mardin channery silt loam, 3 to 8 percent slopes	7.9	2.0%
MrC	Mardin channery silt loam, 8 to 15 percent slopes	23.3	5.9%
MrD	Mardin channery silt loam, 15 to 25 percent slopes	0.6	0.2%
TuB	Tuller channery silt loam, 3 to 8 percent slopes	1.6	0.4%
TuC	Tuller channery silt loam, 8 to 15 percent slopes	2.8	0.7%
VaB	Valois gravelly silt loam, 3 to 8 percent slopes	9.5	2.4%
VaD	Valois gravelly silt loam, 15 to 25 percent slopes	0.9	0.2%
VoB	Volusia channery silt loam, 3 to 8 percent slopes	164.5	41.8%
VoC	Volusia channery silt loam, 8 to 15 percent slopes	143.9	36.5%
VoD	Volusia channery silt loam, 15 to 25 percent slopes	20.0	5.1%
Totals for Area of Interest		393.7	100.0%

Map Unit Descriptions

The map units delineated on the detailed soil maps in a soil survey represent the soils or miscellaneous areas in the survey area. The map unit descriptions, along with the maps, can be used to determine the composition and properties of a unit.

A map unit delineation on a soil map represents an area dominated by one or more major kinds of soil or miscellaneous areas. A map unit is identified and named according to the taxonomic classification of the dominant soils. Within a taxonomic class there are precisely defined limits for the properties of the soils. On the landscape, however, the soils are natural phenomena, and they have the characteristic variability of all natural phenomena. Thus, the range of some observed properties may extend beyond the limits defined for a taxonomic class. Areas of soils of a single taxonomic class rarely, if ever, can be mapped without including areas of other taxonomic classes. Consequently, every map unit is made

Custom Soil Resource Report

up of the soils or miscellaneous areas for which it is named and some minor components that belong to taxonomic classes other than those of the major soils.

Most minor soils have properties similar to those of the dominant soil or soils in the map unit, and thus they do not affect use and management. These are called noncontrasting, or similar, components. They may or may not be mentioned in a particular map unit description. Other minor components, however, have properties and behavioral characteristics divergent enough to affect use or to require different management. These are called contrasting, or dissimilar, components. They generally are in small areas and could not be mapped separately because of the scale used. Some small areas of strongly contrasting soils or miscellaneous areas are identified by a special symbol on the maps. If included in the database for a given area, the contrasting minor components are identified in the map unit descriptions along with some characteristics of each. A few areas of minor components may not have been observed, and consequently they are not mentioned in the descriptions, especially where the pattern was so complex that it was impractical to make enough observations to identify all the soils and miscellaneous areas on the landscape.

The presence of minor components in a map unit in no way diminishes the usefulness or accuracy of the data. The objective of mapping is not to delineate pure taxonomic classes but rather to separate the landscape into landforms or landform segments that have similar use and management requirements. The delineation of such segments on the map provides sufficient information for the development of resource plans. If intensive use of small areas is planned, however, onsite investigation is needed to define and locate the soils and miscellaneous areas.

An identifying symbol precedes the map unit name in the map unit descriptions. Each description includes general facts about the unit and gives important soil properties and qualities.

Soils that have profiles that are almost alike make up a *soil series*. Except for differences in texture of the surface layer, all the soils of a series have major horizons that are similar in composition, thickness, and arrangement.

Soils of one series can differ in texture of the surface layer, slope, stoniness, salinity, degree of erosion, and other characteristics that affect their use. On the basis of such differences, a soil series is divided into *soil phases*. Most of the areas shown on the detailed soil maps are phases of soil series. The name of a soil phase commonly indicates a feature that affects use or management. For example, Alpha silt loam, 0 to 2 percent slopes, is a phase of the Alpha series.

Some map units are made up of two or more major soils or miscellaneous areas. These map units are complexes, associations, or undifferentiated groups.

A *complex* consists of two or more soils or miscellaneous areas in such an intricate pattern or in such small areas that they cannot be shown separately on the maps. The pattern and proportion of the soils or miscellaneous areas are somewhat similar in all areas. Alpha-Beta complex, 0 to 6 percent slopes, is an example.

An *association* is made up of two or more geographically associated soils or miscellaneous areas that are shown as one unit on the maps. Because of present or anticipated uses of the map units in the survey area, it was not considered practical or necessary to map the soils or miscellaneous areas separately. The pattern and relative proportion of the soils or miscellaneous areas are somewhat similar. Alpha-Beta association, 0 to 2 percent slopes, is an example.

Custom Soil Resource Report

An *undifferentiated group* is made up of two or more soils or miscellaneous areas that could be mapped individually but are mapped as one unit because similar interpretations can be made for use and management. The pattern and proportion of the soils or miscellaneous areas in a mapped area are not uniform. An area can be made up of only one of the major soils or miscellaneous areas, or it can be made up of all of them. Alpha and Beta soils, 0 to 2 percent slopes, is an example.

Some surveys include *miscellaneous areas*. Such areas have little or no soil material and support little or no vegetation. Rock outcrop is an example.

Schuyler County, New York

Cp—Chippewa silt loam, 0 to 3 percent slopes

Map Unit Setting

National map unit symbol: 2v32k

Elevation: 330 to 2,460 feet

Mean annual precipitation: 31 to 70 inches

Mean annual air temperature: 39 to 52 degrees F

Frost-free period: 105 to 180 days

Farmland classification: Farmland of statewide importance

Map Unit Composition

Chippewa and similar soils: 85 percent

Minor components: 15 percent

Estimates are based on observations, descriptions, and transects of the mapunit.

Description of Chippewa

Setting

Landform: Depressions

Landform position (two-dimensional): Toeslope

Landform position (three-dimensional): Base slope

Down-slope shape: Concave

Across-slope shape: Concave

Parent material: Loamy till dominated by siltstone, sandstone, and shale fragments

Typical profile

Ap - 0 to 7 inches: silt loam

Eg - 7 to 15 inches: channery silt loam

Bxg - 15 to 45 inches: channery silt loam

C - 45 to 72 inches: channery silt loam

Properties and qualities

Slope: 0 to 3 percent

Percent of area covered with surface fragments: 0.0 percent

Depth to restrictive feature: 8 to 20 inches to fragipan

Natural drainage class: Poorly drained

Capacity of the most limiting layer to transmit water (Ksat): Very low to moderately low (0.00 to 0.14 in/hr)

Depth to water table: About 0 to 6 inches

Frequency of flooding: None

Frequency of ponding: None

Calcium carbonate, maximum in profile: 15 percent

Available water storage in profile: Low (about 3.1 inches)

Interpretive groups

Land capability classification (irrigated): None specified

Land capability classification (nonirrigated): 4w

Hydrologic Soil Group: D

Ecological site: Mineral Wetlands (F140XY016NY)

Hydric soil rating: Yes

Minor Components

Chippewa, very poorly drained

Percent of map unit: 10 percent
Landform: Depressions
Landform position (two-dimensional): Toeslope
Landform position (three-dimensional): Base slope
Down-slope shape: Concave
Across-slope shape: Concave
Hydric soil rating: Yes

Volusia

Percent of map unit: 5 percent
Landform: Hills, mountains
Landform position (two-dimensional): Foothills, summit
Landform position (three-dimensional): Base slope, interfluvium, side slope
Down-slope shape: Concave
Across-slope shape: Linear
Hydric soil rating: No

FrB—Fremont silt loam, 3 to 8 percent slopes

Map Unit Setting

National map unit symbol: 2vzrc
Elevation: 330 to 2,460 feet
Mean annual precipitation: 31 to 70 inches
Mean annual air temperature: 39 to 52 degrees F
Frost-free period: 105 to 180 days
Farmland classification: Farmland of statewide importance

Map Unit Composition

Fremont and similar soils: 80 percent
Minor components: 20 percent
Estimates are based on observations, descriptions, and transects of the mapunit.

Description of Fremont

Setting

Landform: Hills
Landform position (two-dimensional): Foothills, summit
Landform position (three-dimensional): Base slope, interfluvium
Down-slope shape: Concave
Across-slope shape: Linear
Parent material: Till

Typical profile

Ap - 0 to 8 inches: silt loam
Bw1 - 8 to 16 inches: silt loam
Bw2 - 16 to 30 inches: channery silt loam
BC - 30 to 34 inches: channery silty clay loam

Custom Soil Resource Report

C - 34 to 72 inches: channery silt loam

Properties and qualities

Slope: 3 to 8 percent

Depth to restrictive feature: More than 80 inches

Natural drainage class: Somewhat poorly drained

Capacity of the most limiting layer to transmit water (Ksat): Very low to moderately low (0.00 to 0.14 in/hr)

Depth to water table: About 6 to 18 inches

Frequency of flooding: None

Frequency of ponding: None

Salinity, maximum in profile: Nonsaline (0.0 to 1.9 mmhos/cm)

Available water storage in profile: High (about 10.5 inches)

Interpretive groups

Land capability classification (irrigated): None specified

Land capability classification (nonirrigated): 3w

Hydrologic Soil Group: D

Ecological site: Moist Till Highlands (F139XY006OH)

Hydric soil rating: No

Minor Components

Volusia

Percent of map unit: 5 percent

Landform: Hills, mountains

Landform position (two-dimensional): Foothills, summit

Landform position (three-dimensional): Base slope, interfluvium, side slope

Down-slope shape: Concave

Across-slope shape: Linear

Hydric soil rating: No

Orpark

Percent of map unit: 5 percent

Landform: Benches, till plains, ridges

Landform position (two-dimensional): Foothills, shoulder, backslope

Landform position (three-dimensional): Base slope, crest, nose slope

Down-slope shape: Concave, convex

Across-slope shape: Linear

Hydric soil rating: No

Schuyler

Percent of map unit: 5 percent

Landform: Hills

Landform position (two-dimensional): Shoulder, backslope

Landform position (three-dimensional): Interfluvium, side slope

Down-slope shape: Linear

Across-slope shape: Linear

Hydric soil rating: No

Ashville

Percent of map unit: 5 percent

Landform: Depressions

Landform position (two-dimensional): Toeslope

Landform position (three-dimensional): Base slope

Down-slope shape: Concave

Across-slope shape: Concave

Custom Soil Resource Report

Hydric soil rating: Yes

LoC—Lordstown channery silt loam, 8 to 15 percent slopes

Map Unit Setting

National map unit symbol: 2wzl1

Elevation: 330 to 2,460 feet

Mean annual precipitation: 31 to 70 inches

Mean annual air temperature: 39 to 52 degrees F

Frost-free period: 105 to 180 days

Farmland classification: Farmland of statewide importance

Map Unit Composition

Lordstown and similar soils: 90 percent

Minor components: 10 percent

Estimates are based on observations, descriptions, and transects of the mapunit.

Description of Lordstown

Setting

Landform: Mountains, hills

Landform position (two-dimensional): Shoulder, backslope

Landform position (three-dimensional): Mountaintop, crest, nose slope

Down-slope shape: Convex

Across-slope shape: Linear

Parent material: Loamy till derived from sandstone and siltstone

Typical profile

Ap - 0 to 9 inches: channery silt loam

Bw1 - 9 to 17 inches: channery silt loam

Bw2 - 17 to 24 inches: very channery silt loam

C - 24 to 30 inches: extremely channery silt loam

2R - 30 to 40 inches: bedrock

Properties and qualities

Slope: 8 to 15 percent

Percent of area covered with surface fragments: 0.0 percent

Depth to restrictive feature: 20 to 40 inches to lithic bedrock

Natural drainage class: Well drained

Capacity of the most limiting layer to transmit water (Ksat): Moderately low to moderately high (0.14 to 1.42 in/hr)

Depth to water table: More than 80 inches

Frequency of flooding: None

Frequency of ponding: None

Salinity, maximum in profile: Nonsaline (0.0 to 1.9 mmhos/cm)

Available water storage in profile: Low (about 4.1 inches)

Interpretive groups

Land capability classification (irrigated): None specified

Land capability classification (nonirrigated): 3e

Hydrologic Soil Group: C

Custom Soil Resource Report

Hydric soil rating: No

Minor Components

Mardin

Percent of map unit: 5 percent

Landform: Hills, mountains

Landform position (two-dimensional): Summit, shoulder

Landform position (three-dimensional): Interfluve, side slope

Down-slope shape: Convex

Across-slope shape: Convex

Hydric soil rating: No

Arnot

Percent of map unit: 5 percent

Landform: Mountains, hills

Landform position (two-dimensional): Summit, shoulder

Landform position (three-dimensional): Mountaintop, interfluve, crest

Down-slope shape: Convex

Across-slope shape: Convex

Hydric soil rating: No

MrB—Mardin channery silt loam, 3 to 8 percent slopes

Map Unit Setting

National map unit symbol: 2srhb

Elevation: 330 to 2,460 feet

Mean annual precipitation: 31 to 70 inches

Mean annual air temperature: 39 to 52 degrees F

Frost-free period: 105 to 180 days

Farmland classification: Farmland of statewide importance

Map Unit Composition

Mardin and similar soils: 85 percent

Minor components: 15 percent

Estimates are based on observations, descriptions, and transects of the mapunit.

Description of Mardin

Setting

Landform: Hills, mountains

Landform position (two-dimensional): Summit, shoulder

Landform position (three-dimensional): Interfluve, side slope

Down-slope shape: Convex

Across-slope shape: Convex

Parent material: Loamy till

Typical profile

Ap - 0 to 8 inches: channery silt loam

BE - 8 to 12 inches: channery silt loam

Bw1 - 12 to 16 inches: channery silt loam

Custom Soil Resource Report

Bw2 - 16 to 20 inches: channery silt loam
Bx1 - 20 to 36 inches: channery silt loam
Bx2 - 36 to 57 inches: channery silt loam
C - 57 to 72 inches: channery silt loam

Properties and qualities

Slope: 3 to 8 percent
Percent of area covered with surface fragments: 0.0 percent
Depth to restrictive feature: 14 to 26 inches to fragipan
Natural drainage class: Moderately well drained
Capacity of the most limiting layer to transmit water (Ksat): Very low to moderately low (0.00 to 0.14 in/hr)
Depth to water table: About 13 to 24 inches
Frequency of flooding: None
Frequency of ponding: None
Available water storage in profile: Low (about 3.6 inches)

Interpretive groups

Land capability classification (irrigated): None specified
Land capability classification (nonirrigated): 2w
Hydrologic Soil Group: D
Hydric soil rating: No

Minor Components

Volusia

Percent of map unit: 5 percent
Landform: Mountains, hills
Landform position (two-dimensional): Footslope, summit
Landform position (three-dimensional): Base slope, interfluvium, side slope
Down-slope shape: Concave
Across-slope shape: Linear
Hydric soil rating: No

Bath

Percent of map unit: 5 percent
Landform: Hills, mountains
Landform position (two-dimensional): Shoulder, backslope
Landform position (three-dimensional): Interfluvium, side slope
Down-slope shape: Concave
Across-slope shape: Linear
Hydric soil rating: No

Lordstown

Percent of map unit: 5 percent
Landform: Hills, mountains
Landform position (two-dimensional): Summit, shoulder
Landform position (three-dimensional): Mountaintop, interfluvium, crest
Down-slope shape: Convex
Across-slope shape: Convex
Hydric soil rating: No

MrC—Mardin channery silt loam, 8 to 15 percent slopes

Map Unit Setting

National map unit symbol: 2srhj
Elevation: 330 to 2,460 feet
Mean annual precipitation: 31 to 70 inches
Mean annual air temperature: 39 to 52 degrees F
Frost-free period: 105 to 180 days
Farmland classification: Farmland of statewide importance

Map Unit Composition

Mardin and similar soils: 88 percent
Minor components: 12 percent
Estimates are based on observations, descriptions, and transects of the mapunit.

Description of Mardin

Setting

Landform: Hills, mountains
Landform position (two-dimensional): Shoulder, backslope
Landform position (three-dimensional): Interfluve, side slope
Down-slope shape: Linear
Across-slope shape: Linear
Parent material: Loamy till

Typical profile

Ap - 0 to 8 inches: channery silt loam
BE - 8 to 12 inches: channery silt loam
Bw1 - 12 to 16 inches: channery silt loam
Bw2 - 16 to 20 inches: channery silt loam
Bx1 - 20 to 36 inches: channery silt loam
Bx2 - 36 to 57 inches: channery silt loam
C - 57 to 72 inches: channery silt loam

Properties and qualities

Slope: 8 to 15 percent
Percent of area covered with surface fragments: 0.0 percent
Depth to restrictive feature: 14 to 26 inches to fragipan
Natural drainage class: Moderately well drained
Capacity of the most limiting layer to transmit water (Ksat): Very low to moderately low (0.00 to 0.14 in/hr)
Depth to water table: About 13 to 24 inches
Frequency of flooding: None
Frequency of ponding: None
Available water storage in profile: Low (about 3.6 inches)

Interpretive groups

Land capability classification (irrigated): None specified
Land capability classification (nonirrigated): 3e
Hydrologic Soil Group: D

Custom Soil Resource Report

Hydric soil rating: No

Minor Components

Bath

Percent of map unit: 5 percent

Landform: Mountains, hills

Landform position (two-dimensional): Backslope

Landform position (three-dimensional): Nose slope, side slope

Down-slope shape: Linear

Across-slope shape: Linear

Hydric soil rating: No

Volusia

Percent of map unit: 5 percent

Landform: Hills, mountains

Landform position (two-dimensional): Footslope, summit

Landform position (three-dimensional): Base slope, interfluvium, side slope

Down-slope shape: Concave

Across-slope shape: Linear

Hydric soil rating: No

Lordstown

Percent of map unit: 2 percent

Landform: Mountains, hills

Landform position (two-dimensional): Backslope

Landform position (three-dimensional): Mountaintop, side slope, nose slope

Down-slope shape: Linear

Across-slope shape: Linear

Hydric soil rating: No

MrD—Mardin channery silt loam, 15 to 25 percent slopes

Map Unit Setting

National map unit symbol: 2srh8

Elevation: 330 to 2,460 feet

Mean annual precipitation: 31 to 70 inches

Mean annual air temperature: 39 to 52 degrees F

Frost-free period: 105 to 180 days

Farmland classification: Not prime farmland

Map Unit Composition

Mardin and similar soils: 85 percent

Minor components: 15 percent

Estimates are based on observations, descriptions, and transects of the mapunit.

Description of Mardin

Setting

Landform: Hills, mountains

Landform position (two-dimensional): Backslope

Custom Soil Resource Report

Landform position (three-dimensional): Side slope, head slope
Down-slope shape: Concave
Across-slope shape: Linear
Parent material: Loamy till

Typical profile

Ap - 0 to 8 inches: channery silt loam
BE - 8 to 12 inches: channery silt loam
Bw1 - 12 to 16 inches: channery silt loam
Bw2 - 16 to 20 inches: channery silt loam
Bx1 - 20 to 36 inches: channery silt loam
Bx2 - 36 to 57 inches: channery silt loam
C - 57 to 72 inches: channery silt loam

Properties and qualities

Slope: 15 to 25 percent
Percent of area covered with surface fragments: 0.0 percent
Depth to restrictive feature: 14 to 26 inches to fragipan
Natural drainage class: Moderately well drained
Capacity of the most limiting layer to transmit water (Ksat): Very low to moderately low (0.00 to 0.14 in/hr)
Depth to water table: About 13 to 24 inches
Frequency of flooding: None
Frequency of ponding: None
Available water storage in profile: Low (about 3.6 inches)

Interpretive groups

Land capability classification (irrigated): None specified
Land capability classification (nonirrigated): 4e
Hydrologic Soil Group: D
Hydric soil rating: No

Minor Components

Bath

Percent of map unit: 5 percent
Landform: Hills, mountains
Landform position (two-dimensional): Backslope
Landform position (three-dimensional): Nose slope, side slope
Down-slope shape: Linear
Across-slope shape: Linear
Hydric soil rating: No

Volusia

Percent of map unit: 5 percent
Landform: Mountains, hills
Landform position (two-dimensional): Footslope
Landform position (three-dimensional): Interfluve, side slope
Down-slope shape: Concave
Across-slope shape: Linear
Hydric soil rating: No

Lordstown

Percent of map unit: 5 percent
Landform: Mountains, hills
Landform position (two-dimensional): Backslope
Landform position (three-dimensional): Mountaintop, side slope, nose slope

Custom Soil Resource Report

Down-slope shape: Linear
Across-slope shape: Linear
Hydric soil rating: No

TuB—Tuller channery silt loam, 3 to 8 percent slopes

Map Unit Setting

National map unit symbol: 9wm1
Elevation: 600 to 1,800 feet
Mean annual precipitation: 32 to 40 inches
Mean annual air temperature: 45 to 48 degrees F
Frost-free period: 120 to 160 days
Farmland classification: Farmland of statewide importance

Map Unit Composition

Tuller and similar soils: 75 percent
Minor components: 25 percent
Estimates are based on observations, descriptions, and transects of the mapunit.

Description of Tuller

Setting

Landform: Hills, ridges, benches
Landform position (two-dimensional): Footslope, summit
Landform position (three-dimensional): Base slope
Down-slope shape: Concave
Across-slope shape: Linear
Parent material: Loamy till derived mainly from acid sandstone, siltstone, and shale

Typical profile

H1 - 0 to 7 inches: channery silt loam
H2 - 7 to 18 inches: channery silt loam
H3 - 18 to 22 inches: unweathered bedrock

Properties and qualities

Slope: 3 to 8 percent
Depth to restrictive feature: 10 to 20 inches to lithic bedrock
Natural drainage class: Somewhat poorly drained
Capacity of the most limiting layer to transmit water (Ksat): Very low (0.00 to 0.00 in/hr)
Depth to water table: About 6 to 12 inches
Frequency of flooding: None
Frequency of ponding: None
Available water storage in profile: Very low (about 1.7 inches)

Interpretive groups

Land capability classification (irrigated): None specified
Land capability classification (nonirrigated): 3w
Hydrologic Soil Group: D
Ecological site: Mineral Wetlands (F140XY016NY)

Hydric soil rating: No

Minor Components

Volusia

Percent of map unit: 5 percent

Hydric soil rating: No

Arnot

Percent of map unit: 5 percent

Hydric soil rating: No

Alden

Percent of map unit: 5 percent

Landform: Depressions

Hydric soil rating: Yes

Erie

Percent of map unit: 5 percent

Hydric soil rating: No

Lordstown

Percent of map unit: 5 percent

Hydric soil rating: No

TuC—Tuller channery silt loam, 8 to 15 percent slopes

Map Unit Setting

National map unit symbol: 9wm2

Elevation: 600 to 1,800 feet

Mean annual precipitation: 32 to 40 inches

Mean annual air temperature: 45 to 48 degrees F

Frost-free period: 120 to 160 days

Farmland classification: Not prime farmland

Map Unit Composition

Tuller and similar soils: 75 percent

Minor components: 25 percent

Estimates are based on observations, descriptions, and transects of the mapunit.

Description of Tuller

Setting

Landform: Hills, ridges, benches

Landform position (two-dimensional): Footslope

Landform position (three-dimensional): Base slope

Down-slope shape: Concave

Across-slope shape: Linear

Parent material: Loamy till derived mainly from acid sandstone, siltstone, and shale

Custom Soil Resource Report

Typical profile

H1 - 0 to 5 inches: channery silt loam
H2 - 5 to 15 inches: channery silt loam
H3 - 15 to 22 inches: unweathered bedrock

Properties and qualities

Slope: 8 to 15 percent
Depth to restrictive feature: 10 to 20 inches to lithic bedrock
Natural drainage class: Somewhat poorly drained
Capacity of the most limiting layer to transmit water (Ksat): Very low (0.00 to 0.00 in/hr)
Depth to water table: About 6 to 12 inches
Frequency of flooding: None
Frequency of ponding: None
Available water storage in profile: Very low (about 1.4 inches)

Interpretive groups

Land capability classification (irrigated): None specified
Land capability classification (nonirrigated): 4e
Hydrologic Soil Group: D
Ecological site: Mineral Wetlands (F140XY016NY)
Hydric soil rating: No

Minor Components

Lordstown

Percent of map unit: 5 percent
Hydric soil rating: No

Volusia

Percent of map unit: 5 percent
Hydric soil rating: No

Alden

Percent of map unit: 5 percent
Landform: Depressions
Hydric soil rating: Yes

Erie

Percent of map unit: 5 percent
Hydric soil rating: No

Arnot

Percent of map unit: 5 percent
Hydric soil rating: No

VaB—Valois gravelly silt loam, 3 to 8 percent slopes

Map Unit Setting

National map unit symbol: 9wm4
Elevation: 600 to 1,750 feet
Mean annual precipitation: 32 to 40 inches

Custom Soil Resource Report

Mean annual air temperature: 45 to 48 degrees F

Frost-free period: 120 to 160 days

Farmland classification: All areas are prime farmland

Map Unit Composition

Valois and similar soils: 80 percent

Minor components: 20 percent

Estimates are based on observations, descriptions, and transects of the mapunit.

Description of Valois

Setting

Landform: End moraines, valley sides, lateral moraines

Landform position (two-dimensional): Summit

Landform position (three-dimensional): Crest

Down-slope shape: Convex

Across-slope shape: Convex

Parent material: Loamy till derived mainly from sandstone, siltstone, and shale

Typical profile

H1 - 0 to 8 inches: gravelly silt loam

H2 - 8 to 36 inches: gravelly loam

H3 - 36 to 48 inches: gravelly sandy loam

H4 - 48 to 60 inches: very gravelly sandy loam

Properties and qualities

Slope: 3 to 8 percent

Depth to restrictive feature: More than 80 inches

Natural drainage class: Well drained

Capacity of the most limiting layer to transmit water (Ksat): Moderately high to high (0.57 to 1.98 in/hr)

Depth to water table: More than 80 inches

Frequency of flooding: None

Frequency of ponding: None

Calcium carbonate, maximum in profile: 2 percent

Available water storage in profile: Moderate (about 6.1 inches)

Interpretive groups

Land capability classification (irrigated): None specified

Land capability classification (nonirrigated): 2e

Hydrologic Soil Group: B

Hydric soil rating: No

Minor Components

Howard

Percent of map unit: 5 percent

Hydric soil rating: No

Lansing

Percent of map unit: 5 percent

Hydric soil rating: No

Bath

Percent of map unit: 5 percent

Hydric soil rating: No

Mardin

Percent of map unit: 5 percent
Hydric soil rating: No

VaD—Valois gravelly silt loam, 15 to 25 percent slopes

Map Unit Setting

National map unit symbol: 9wm6
Elevation: 600 to 1,750 feet
Mean annual precipitation: 32 to 40 inches
Mean annual air temperature: 45 to 48 degrees F
Frost-free period: 120 to 160 days
Farmland classification: Not prime farmland

Map Unit Composition

Valois and similar soils: 75 percent
Minor components: 25 percent
Estimates are based on observations, descriptions, and transects of the mapunit.

Description of Valois

Setting

Landform: End moraines, valley sides, lateral moraines
Landform position (two-dimensional): Backslope
Landform position (three-dimensional): Side slope
Down-slope shape: Convex
Across-slope shape: Convex
Parent material: Loamy till derived mainly from sandstone, siltstone, and shale

Typical profile

H1 - 0 to 4 inches: gravelly silt loam
H2 - 4 to 30 inches: gravelly loam
H3 - 30 to 42 inches: gravelly sandy loam
H4 - 42 to 60 inches: very gravelly sandy loam

Properties and qualities

Slope: 15 to 25 percent
Depth to restrictive feature: More than 80 inches
Natural drainage class: Well drained
Capacity of the most limiting layer to transmit water (Ksat): Moderately high to high (0.57 to 1.98 in/hr)
Depth to water table: More than 80 inches
Frequency of flooding: None
Frequency of ponding: None
Calcium carbonate, maximum in profile: 2 percent
Available water storage in profile: Low (about 5.7 inches)

Interpretive groups

Land capability classification (irrigated): None specified
Land capability classification (nonirrigated): 4e

Custom Soil Resource Report

Hydrologic Soil Group: B
Hydric soil rating: No

Minor Components

Lansing

Percent of map unit: 5 percent
Hydric soil rating: No

Mardin

Percent of map unit: 5 percent
Hydric soil rating: No

Chenango

Percent of map unit: 5 percent
Hydric soil rating: No

Lordstown

Percent of map unit: 5 percent
Hydric soil rating: No

Bath

Percent of map unit: 5 percent
Hydric soil rating: No

VoB—Volusia channery silt loam, 3 to 8 percent slopes

Map Unit Setting

National map unit symbol: 2srfh
Elevation: 330 to 2,460 feet
Mean annual precipitation: 31 to 70 inches
Mean annual air temperature: 39 to 52 degrees F
Frost-free period: 105 to 180 days
Farmland classification: Farmland of statewide importance

Map Unit Composition

Volusia and similar soils: 90 percent
Minor components: 10 percent
Estimates are based on observations, descriptions, and transects of the mapunit.

Description of Volusia

Setting

Landform: Mountains, hills
Landform position (two-dimensional): Footslope, summit
Landform position (three-dimensional): Base slope, interfluve, side slope
Down-slope shape: Concave
Across-slope shape: Linear
Parent material: Loamy till derived from interbedded sedimentary rock

Typical profile

Ap - 0 to 9 inches: channery silt loam

Custom Soil Resource Report

Bw - 9 to 15 inches: channery silt loam
Eg - 15 to 17 inches: channery silt loam
Bx1 - 17 to 29 inches: channery loam
Bx2 - 29 to 54 inches: channery loam
C - 54 to 72 inches: channery silt loam

Properties and qualities

Slope: 3 to 8 percent
Percent of area covered with surface fragments: 0.0 percent
Depth to restrictive feature: 10 to 22 inches to fragipan
Natural drainage class: Somewhat poorly drained
Capacity of the most limiting layer to transmit water (Ksat): Very low to moderately low (0.00 to 0.14 in/hr)
Depth to water table: About 6 to 18 inches
Frequency of flooding: None
Frequency of ponding: None
Calcium carbonate, maximum in profile: 5 percent
Available water storage in profile: Very low (about 3.0 inches)

Interpretive groups

Land capability classification (irrigated): None specified
Land capability classification (nonirrigated): 3w
Hydrologic Soil Group: D
Ecological site: Moist Dense Till (F140XY024NY)
Hydric soil rating: No

Minor Components

Mardin

Percent of map unit: 5 percent
Landform: Hills, mountains
Landform position (two-dimensional): Shoulder, backslope
Landform position (three-dimensional): Interfluve, side slope
Down-slope shape: Linear
Across-slope shape: Linear
Hydric soil rating: No

Chippewa

Percent of map unit: 5 percent
Landform: Depressions
Landform position (two-dimensional): Toeslope
Landform position (three-dimensional): Base slope
Down-slope shape: Concave
Across-slope shape: Concave
Hydric soil rating: Yes

VoC—Volusia channery silt loam, 8 to 15 percent slopes

Map Unit Setting

National map unit symbol: 2srfj
Elevation: 330 to 2,460 feet

Custom Soil Resource Report

Mean annual precipitation: 31 to 70 inches
Mean annual air temperature: 39 to 52 degrees F
Frost-free period: 105 to 180 days
Farmland classification: Farmland of statewide importance

Map Unit Composition

Volusia and similar soils: 90 percent
Minor components: 10 percent
Estimates are based on observations, descriptions, and transects of the mapunit.

Description of Volusia

Setting

Landform: Hills, mountains
Landform position (two-dimensional): Footslope
Landform position (three-dimensional): Interfluve, side slope
Down-slope shape: Concave
Across-slope shape: Linear
Parent material: Loamy till derived from interbedded sedimentary rock

Typical profile

Ap - 0 to 9 inches: channery silt loam
Bw - 9 to 15 inches: channery silt loam
Eg - 15 to 17 inches: channery silt loam
Bx1 - 17 to 29 inches: channery loam
Bx2 - 29 to 54 inches: channery loam
C - 54 to 72 inches: channery silt loam

Properties and qualities

Slope: 8 to 15 percent
Percent of area covered with surface fragments: 0.0 percent
Depth to restrictive feature: 10 to 22 inches to fragipan
Natural drainage class: Somewhat poorly drained
Capacity of the most limiting layer to transmit water (Ksat): Very low to moderately low (0.00 to 0.14 in/hr)
Depth to water table: About 6 to 18 inches
Frequency of flooding: None
Frequency of ponding: None
Calcium carbonate, maximum in profile: 5 percent
Available water storage in profile: Very low (about 3.0 inches)

Interpretive groups

Land capability classification (irrigated): None specified
Land capability classification (nonirrigated): 3e
Hydrologic Soil Group: D
Ecological site: Moist Dense Till (F140XY024NY)
Hydric soil rating: No

Minor Components

Mardin

Percent of map unit: 6 percent
Landform: Hills, mountains
Landform position (two-dimensional): Backslope
Landform position (three-dimensional): Side slope, head slope
Down-slope shape: Concave
Across-slope shape: Linear

Custom Soil Resource Report

Hydric soil rating: No

Chippewa

Percent of map unit: 4 percent

Landform: Depressions

Landform position (two-dimensional): Toeslope

Landform position (three-dimensional): Base slope

Down-slope shape: Concave

Across-slope shape: Concave

Hydric soil rating: Yes

VoD—Volusia channery silt loam, 15 to 25 percent slopes

Map Unit Setting

National map unit symbol: 2srfl

Elevation: 330 to 2,460 feet

Mean annual precipitation: 31 to 70 inches

Mean annual air temperature: 39 to 52 degrees F

Frost-free period: 105 to 180 days

Farmland classification: Not prime farmland

Map Unit Composition

Volusia and similar soils: 90 percent

Minor components: 10 percent

Estimates are based on observations, descriptions, and transects of the mapunit.

Description of Volusia

Setting

Landform: Hills, mountains

Landform position (two-dimensional): Backslope, footslope

Landform position (three-dimensional): Side slope, head slope

Down-slope shape: Concave

Across-slope shape: Linear

Parent material: Loamy till derived from interbedded sedimentary rock

Typical profile

Ap - 0 to 9 inches: channery silt loam

Bw - 9 to 15 inches: channery silt loam

Eg - 15 to 17 inches: channery silt loam

Bx1 - 17 to 29 inches: channery loam

Bx2 - 29 to 54 inches: channery loam

C - 54 to 72 inches: channery silt loam

Properties and qualities

Slope: 15 to 25 percent

Percent of area covered with surface fragments: 0.0 percent

Depth to restrictive feature: 10 to 22 inches to fragipan

Natural drainage class: Somewhat poorly drained

Capacity of the most limiting layer to transmit water (Ksat): Very low to moderately low (0.00 to 0.14 in/hr)

Custom Soil Resource Report

Depth to water table: About 6 to 18 inches
Frequency of flooding: None
Frequency of ponding: None
Calcium carbonate, maximum in profile: 5 percent
Available water storage in profile: Very low (about 3.0 inches)

Interpretive groups

Land capability classification (irrigated): None specified
Land capability classification (nonirrigated): 4e
Hydrologic Soil Group: D
Ecological site: Moist Dense Till (F140XY024NY)
Hydric soil rating: No

Minor Components

Mardin

Percent of map unit: 7 percent
Landform: Hills, mountains
Landform position (two-dimensional): Backslope
Landform position (three-dimensional): Side slope, head slope
Down-slope shape: Concave
Across-slope shape: Linear
Hydric soil rating: No

Chippewa

Percent of map unit: 3 percent
Landform: Depressions
Landform position (two-dimensional): Toeslope
Landform position (three-dimensional): Base slope
Down-slope shape: Concave
Across-slope shape: Concave
Hydric soil rating: Yes

References

- American Association of State Highway and Transportation Officials (AASHTO). 2004. Standard specifications for transportation materials and methods of sampling and testing. 24th edition.
- American Society for Testing and Materials (ASTM). 2005. Standard classification of soils for engineering purposes. ASTM Standard D2487-00.
- Cowardin, L.M., V. Carter, F.C. Golet, and E.T. LaRoe. 1979. Classification of wetlands and deep-water habitats of the United States. U.S. Fish and Wildlife Service FWS/OBS-79/31.
- Federal Register. July 13, 1994. Changes in hydric soils of the United States.
- Federal Register. September 18, 2002. Hydric soils of the United States.
- Hurt, G.W., and L.M. Vasilas, editors. Version 6.0, 2006. Field indicators of hydric soils in the United States.
- National Research Council. 1995. Wetlands: Characteristics and boundaries.
- Soil Survey Division Staff. 1993. Soil survey manual. Soil Conservation Service. U.S. Department of Agriculture Handbook 18. http://www.nrcs.usda.gov/wps/portal/nrcs/detail/national/soils/?cid=nrcs142p2_054262
- Soil Survey Staff. 1999. Soil taxonomy: A basic system of soil classification for making and interpreting soil surveys. 2nd edition. Natural Resources Conservation Service, U.S. Department of Agriculture Handbook 436. http://www.nrcs.usda.gov/wps/portal/nrcs/detail/national/soils/?cid=nrcs142p2_053577
- Soil Survey Staff. 2010. Keys to soil taxonomy. 11th edition. U.S. Department of Agriculture, Natural Resources Conservation Service. http://www.nrcs.usda.gov/wps/portal/nrcs/detail/national/soils/?cid=nrcs142p2_053580
- Tiner, R.W., Jr. 1985. Wetlands of Delaware. U.S. Fish and Wildlife Service and Delaware Department of Natural Resources and Environmental Control, Wetlands Section.
- United States Army Corps of Engineers, Environmental Laboratory. 1987. Corps of Engineers wetlands delineation manual. Waterways Experiment Station Technical Report Y-87-1.
- United States Department of Agriculture, Natural Resources Conservation Service. National forestry manual. http://www.nrcs.usda.gov/wps/portal/nrcs/detail/soils/home/?cid=nrcs142p2_053374
- United States Department of Agriculture, Natural Resources Conservation Service. National range and pasture handbook. <http://www.nrcs.usda.gov/wps/portal/nrcs/detail/national/landuse/rangepasture/?cid=stelprdb1043084>

Custom Soil Resource Report

United States Department of Agriculture, Natural Resources Conservation Service. National soil survey handbook, title 430-VI. http://www.nrcs.usda.gov/wps/portal/nrcs/detail/soils/scientists/?cid=nrcs142p2_054242

United States Department of Agriculture, Natural Resources Conservation Service. 2006. Land resource regions and major land resource areas of the United States, the Caribbean, and the Pacific Basin. U.S. Department of Agriculture Handbook 296. http://www.nrcs.usda.gov/wps/portal/nrcs/detail/national/soils/?cid=nrcs142p2_053624

United States Department of Agriculture, Soil Conservation Service. 1961. Land capability classification. U.S. Department of Agriculture Handbook 210. http://www.nrcs.usda.gov/Internet/FSE_DOCUMENTS/nrcs142p2_052290.pdf

Appendix F – Preliminary Design Drawings

Refer to Appendix 11-1 of the Article 10 Application for the Preliminary Design Drawings.

Appendix G – Standards and Specifications for Erosion and Sediment Controls

The Standards and Specification for Erosion and Sediment Controls provide are based on the Preliminary Design Drawings.

The Standards and Specifications will be finalized for the Final SWPPP.

STANDARD AND SPECIFICATIONS FOR CONSTRUCTION ROAD STABILIZATION



Definition & Scope

The stabilization of temporary construction access routes, on-site vehicle transportation routes, and construction parking areas to control erosion on temporary construction routes and parking areas.

Conditions Where Practice Applies

All traffic routes and parking areas for temporary use by construction traffic.

Design Criteria

Construction roads should be located to reduce erosion potential, minimize impact on existing site resources, and maintain operations in a safe manner. Highly erosive soils, wet or rocky areas, and steep slopes should be avoided. Roads should be routed where seasonal water tables are deeper than 18 inches. Surface runoff and control should be in accordance with other standards.

Road Grade – A maximum grade of 12% is recommended, although grades up to 15% are possible for short distances.

Road Width – 12 foot minimum for one-way traffic or 24 foot minimum for two-way traffic.

Side Slope of Road Embankment – 2:1 or flatter.

Ditch Capacity – On-site roadside ditch and culvert capacities shall be the 10 yr. peak runoff.

Composition – Use a 6-inch layer of NYS DOT sub-base Types 1,2,3, 4 or equivalent as specified in NYSDOT Standard Specifications.

Construction Specifications

1. Clear and strip roadbed and parking areas of all vegetation, roots, and other objectionable material.
2. Locate parking areas on naturally flat areas as available. Keep grades sufficient for drainage, but not more than 2 to 3 percent.
3. Provide surface drainage and divert excess runoff to stabilized areas.
4. Maintain cut and fill slopes to 2:1 or flatter and stabilized with vegetation as soon as grading is accomplished.
5. Spread 6-inch layer of sub-base material evenly over the full width of the road and smooth to avoid depressions.
6. Provide appropriate sediment control measures to prevent offsite sedimentation.

Maintenance

Inspect construction roads and parking areas periodically for condition of surface. Top dress with new gravel as needed. Check ditches for erosion and sedimentation after rainfall events. Maintain vegetation in a healthy, vigorous condition. Areas producing sediment should be treated immediately.

STANDARD AND SPECIFICATIONS FOR CONCRETE TRUCK WASHOUT



Definition & Scope

A temporary excavated or above ground lined constructed pit where concrete truck mixers and equipment can be washed after their loads have been discharged, to prevent highly alkaline runoff from entering storm drainage systems or leaching into soil.

Conditions Where Practice Applies

Washout facilities shall be provided for every project where concrete will be poured or otherwise formed on the site. This facility will receive highly alkaline wash water from the cleaning of chutes, mixers, hoppers, vibrators, placing equipment, trowels, and screeds. Under no circumstances will wash water from these operations be allowed to infiltrate into the soil or enter surface waters.

Design Criteria

Capacity: The washout facility should be sized to contain solids, wash water, and rainfall and sized to allow for the evaporation of the wash water and rainfall. Wash water shall be estimated at 7 gallons per chute and 50 gallons per hopper of the concrete pump truck and/or discharging drum. The minimum size shall be 8 feet by 8 feet at the bottom and 2 feet deep. If excavated, the side slopes shall be 2 horizontal to 1 vertical.

Location: Locate the facility a minimum of 100 feet from drainage swales, storm drain inlets, wetlands, streams and other surface waters. Prevent surface water from entering the structure except for the access road. Provide appropriate access with a gravel access road sloped down to the structure. Signs shall be placed to direct drivers to the facility after their load is discharged.

Liner: All washout facilities will be lined to prevent

leaching of liquids into the ground. The liner shall be plastic sheeting with a minimum thickness of 10 mils with no holes or tears, and anchored beyond the top of the pit with an earthen berm, sand bags, stone, or other structural appurtenance except at the access point.

If pre-fabricated washouts are used they must ensure the capture and containment of the concrete wash and be sized based on the expected frequency of concrete pours. They shall be sited as noted in the location criteria.

Maintenance

- All concrete washout facilities shall be inspected daily. Damaged or leaking facilities shall be deactivated and repaired or replaced immediately. Excess rainwater that has accumulated over hardened concrete should be pumped to a stabilized area, such as a grass filter strip.
- Accumulated hardened material shall be removed when 75% of the storage capacity of the structure is filled. Any excess wash water shall be pumped into a containment vessel and properly disposed of off site.
- Dispose of the hardened material off-site in a construction/demolition landfill. On-site disposal may be allowed if this has been approved and accepted as part of the projects SWPPP. In that case, the material should be recycled as specified, or buried and covered with a minimum of 2 feet of clean compacted earthfill that is permanently stabilized to prevent erosion.
- The plastic liner shall be replaced with each cleaning of the washout facility.
- Inspect the project site frequently to ensure that no concrete discharges are taking place in non-designated areas.

STANDARD AND SPECIFICATIONS FOR DUST CONTROL



dust control (see Section 3).

Mulch (including gravel mulch) – Mulch offers a fast effective means of controlling dust. This can also include rolled erosion control blankets.

Spray adhesives – These are products generally composed of polymers in a liquid or solid form that are mixed with water to form an emulsion that is sprayed on the soil surface with typical hydroseeding equipment. The mixing ratios and application rates will be in accordance with the manufacturer's recommendations for the specific soils on the site. In no case should the application of these adhesives be made on wet soils or if there is a probability of precipitation within 48 hours of its proposed use. Material Safety Data Sheets will be provided to all applicators and others working with the material.

Definition & Scope

The control of dust resulting from land-disturbing activities, to prevent surface and air movement of dust from disturbed soil surfaces that may cause off-site damage, health hazards, and traffic safety problems.

Conditions Where Practice Applies

On construction roads, access points, and other disturbed areas subject to surface dust movement and dust blowing where off-site damage may occur if dust is not controlled.

Design Criteria

Construction operations should be scheduled to minimize the amount of area disturbed at one time. Buffer areas of vegetation should be left where practical. Temporary or permanent stabilization measures shall be installed. No specific design criteria is given; see construction specifications below for common methods of dust control.

Water quality must be considered when materials are selected for dust control. Where there is a potential for the material to wash off to a stream, ingredient information must be provided to the NYSDEC.

No polymer application shall take place without written approval from the NYSDEC.

Construction Specifications

A. Non-driving Areas – These areas use products and materials applied or placed on soil surfaces to prevent airborne migration of soil particles.

Vegetative Cover – For disturbed areas not subject to traffic, vegetation provides the most practical method of

B. Driving Areas – These areas utilize water, polymer emulsions, and barriers to prevent dust movement from the traffic surface into the air.

Sprinkling – The site may be sprayed with water until the surface is wet. This is especially effective on haul roads and access route to provide short term limited dust control.

Polymer Additives – These polymers are mixed with water and applied to the driving surface by a water truck with a gravity feed drip bar, spray bar or automated distributor truck. The mixing ratios and application rates will be in accordance with the manufacturer's recommendations. Incorporation of the emulsion into the soil will be done to the appropriate depth based on expected traffic. Compaction after incorporation will be by vibratory roller to a minimum of 95%. The prepared surface shall be moist and no application of the polymer will be made if there is a probability of precipitation within 48 hours of its proposed use. Material Safety Data Sheets will be provided to all applicators working with the material.

Barriers – Woven geo-textiles can be placed on the driving surface to effectively reduce dust throw and particle migration on haul roads. Stone can also be used for construction roads for effective dust control.

Windbreak – A silt fence or similar barrier can control air currents at intervals equal to ten times the barrier height. Preserve existing wind barrier vegetation as much as practical.

Maintenance

Maintain dust control measures through dry weather periods until all disturbed areas are stabilized.

STANDARD AND SPECIFICATIONS FOR PROTECTING VEGETATION DURING CONSTRUCTION



Definition & Scope

The protection of trees, shrubs, ground cover and other vegetation from damage by construction equipment. In order to preserve existing vegetation determined to be important for soil erosion control, water quality protection, shade, screening, buffers, wildlife habitat, wetland protection, and other values.

Conditions Where Practices Applies

On planned construction sites where valued vegetation exists and needs to be preserved.

Design Criteria

1. Planning Considerations

A. Inventory:

1) Property boundaries, topography, vegetation and soils information should be gathered. Identify potentially high erosion areas, areas with tree windthrow potential, etc. A vegetative cover type map should be made on a copy of a topographic map which shows other natural and manmade features. Vegetation that is desirable to preserve because of its value for screening, shade, critical erosion control, endangered species, aesthetics, etc., should be identified and marked on the map.

2) Based upon this data, general statements should be prepared about the present condition, potential problem areas, and unique features of the property.

B. Planning:

1) After engineering plans (plot maps) are prepared, another field review should take place and

recommendations made for the vegetation to be saved. Minor adjustments in location of roads, dwellings, and utilities may be needed. Construction on steep slopes, erodible soils, wetlands, and streams should be avoided. Clearing limits should be delineated (See "Determine Limits of Clearing and Grading" on page 2.2).

2) Areas to be seeded and planted should be identified. Remaining vegetation should blend with their surroundings and/or provide special function such as a filter strip, buffer zone, or screen.

3) Trees and shrubs of special seasonal interest, such as flowering dogwood, red maple, striped maple, serviceberry, or shadbush, and valuable potential shade trees should be identified and marked for special protective treatment as appropriate.

4) Trees to be cut should be marked on the plans. If timber can be removed for salable products, a forester should be consulted for marketing advice.

5) Trees that may become a hazard to people, personal property, or utilities should be removed. These include trees that are weak-wooded, disease-prone, subject to windthrow, or those that have severely damaged root systems.

6) The vigor of remaining trees may be improved by a selective thinning. A forester should be consulted for implementing this practice.

2. Measures to Protect Vegetation

A. Limit soil placement over existing tree and shrub roots to a maximum of 3 inches. Soils with loamy texture and good structure should be used.

B. Use retaining walls and terraces to protect roots of trees and shrubs when grades are lowered. Lowered grades should start no closer than the dripline of the tree. For narrow-canopied trees and shrubs, the stem diameter in inches is converted to feet and doubled, such that a 10 inch tree should be protected to 20 feet.

C. Trenching across tree root systems should be the same minimum distance from the trunk, as in "B". Tunnels under root systems for underground utilities should start 18 inches or deeper below the normal ground surface. Tree roots which must be severed should be cut clean. Backfill material that will be in contact with the roots should be topsoil or a prepared planting soil mixture.

D. Construct sturdy fences, or barriers, of wood, steel, or other protective material around valuable

vegetation for protection from construction equipment. Place barriers far enough away from trees, but not less than the specifications in "B", so that tall equipment such as backhoes and dump trucks do not contact tree branches.

E. Construction limits should be identified and clearly marked to exclude equipment.

F. Avoid spills of oil/gas and other contaminants.

G. Obstructive and broken branches should be pruned properly. The branch collar on all branches whether living or dead should not be damaged. The 3 or 4 cut method should be used on all branches larger than two inches at the cut. First cut about one-third the way through the underside of the limb (about 6-12 inches from the tree trunk). Then (approximately an inch further out) make a second cut through the limb from the upper side. When the branch is removed, there is no splintering of the main tree trunk. Remove the stub. If the branch is larger than 5-6 inches in diameter, use the four cut system. Cuts 1 and 2 remain the same and cut 3 should be from the underside of the limb, on the outside of the branch collar. Cut 4 should be from the top and in alignment with the 3rd cut. Cut 3 should be 1/4 to 1/3 the way through the limb. This will prevent the bark from peeling down the trunk. Do not paint the cut surface.

H. Penalties for damage to valuable trees, shrubs, and herbaceous plants should be clearly spelled out in the contract.

PROTECTING TREES IN HEAVY USE AREAS

The compaction of soil over the roots of trees and shrubs by the trampling of recreationists, vehicular traffic, etc., reduces oxygen, water, and nutrient uptake by feeder roots. This weakens and may eventually kill the plants. Table 2.6 rates the "Susceptibility of Tree Species to Compaction."

Where heavy compaction is anticipated, apply and maintain a 3 to 4 inch layer of undecayed wood chips or 2 inches of No. 2 washed, crushed gravel. In addition, use of a wooden or plastic mat may be used to lessen compaction, if applicable.

Table 2.6 Susceptibility of Tree Species to Compaction¹

Resistant:

Box elder.....	<i>Acer negundo</i>	Willows.....	<i>Salix spp.</i>
Green ash.....	<i>Fraxinus pennsylvanica</i>	Honey locust.....	<i>Gleditsia triacanthos</i>
Red elm.....	<i>Ulmus rubra</i>	Eastern cottonwood.....	<i>Populus deltoides</i>
Hawthornes.....	<i>Crataegus spp.</i>	Swamp white oak.....	<i>Quercus bicolor</i>
Bur oak.....	<i>Quercus macrocarpa</i>	Hophornbeam.....	<i>Ostrya virginiana</i>
Northern white cedar....	<i>Thuja occidentalis</i>		

Intermediate:

Red maple.....	<i>Acer rubrum</i>	Sweetgum.....	<i>Liquidambar styraciflua</i>
Silver maple.....	<i>Acer saccharinum</i>	Norway maple.....	<i>Acer platanoides</i>
Hackberry.....	<i>Celtis occidentalis</i>	Shagbark hickory.....	<i>Carya ovata</i>
Black gum.....	<i>Nyssa sylvatica</i>	London plane.....	<i>Platanus x hybrida</i>
Red oak.....	<i>Quercus rubra</i>	Pin oak.....	<i>Quercus palustris</i>
Basswood.....	<i>Tilia americana</i>		

Susceptible:

Sugar maple.....	<i>Acer saccharum</i>	Austrian Pine.....	<i>Pinus nigra</i>
White pine.....	<i>Pinus strobus</i>	White ash.....	<i>Fraxinus americana</i>
Blue spruce.....	<i>Picea pungens</i>	Paper birch.....	<i>Betula papyrifera</i>
White oak.....	<i>Quercus alba</i>	Moutain ash.....	<i>Sorbus aucuparia</i>
Red pine.....	<i>Pinus resinosa</i>	Japanese maple.....	<i>Acer palmatum</i>

¹ If a tree species does not appear on the list, insufficient information is available to rate it for this purpose.

STANDARD AND SPECIFICATIONS FOR SITE POLLUTION PREVENTION



Definition & Scope

A collection of management practices intended to control non-sediment pollutants associated with construction activities to prevent the generation of pollutants due to improper handling, storage, and spills and prevent the movement of toxic substances from the site into surface waters.

Conditions Where Practice Applies

On all construction sites where the earth disturbance exceeds 5,000 square feet, and involves the use of fertilizers, pesticides, petroleum based chemicals, fuels and lubricants, as well as sealers, paints, cleared woody vegetation, garbage, and sanitary wastes.

Design Criteria

The variety of pollutants on a particular site and the severity of their impacts depend on factors such as the nature of the construction activity, the physical characteristics of the construction site, and the proximity of water bodies and conveyances to the pollutant source.

1. All state and federal regulations shall be followed for the storage, handling, application, usage, and disposal of pesticides, fertilizers, and petroleum products.
2. Vehicle and construction equipment staging and maintenance areas will be located away from all drainage ways with their parking areas graded so the runoff from these areas is collected, contained and treated prior to discharge from the site.
3. Provide sanitary facilities for on-site personnel.
4. Store, cover, and isolate construction materials including topsoil, and chemicals, to prevent runoff of

pollutants and contamination of groundwater and surface waters.

5. Develop and implement a spill prevention and control plan. The plan should include NYSDEC's spill reporting and initial notification requirements.
6. Provide adequate disposal for solid waste including woody debris, stumps, and other construction waste and include these methods and directions in the construction details on the site construction drawings. Fill, woody debris, stumps and construction waste shall not be placed in regulated wetlands, streams or other surface waters.
7. Distribute or post informational material regarding proper handling, spill response, spill kit location, and emergency actions to be taken, to all construction personnel.
8. Refueling equipment shall be located at least 100 feet from all wetlands, streams and other surface waters.



STANDARD AND SPECIFICATIONS FOR STABILIZED CONSTRUCTION ACCESS



inert to commonly encountered chemicals, hydro-carbons, mildew, rot resistant, and conform to the fabric properties as shown:

Fabric Properties ³	Light Duty ¹ Roads Grade Sub- grade	Heavy Duty ² Haul Roads Rough Graded	Test Meth- od
Grab Tensile Strength (lbs)	200	220	ASTM D1682
Elongation at Failure (%)	50	60	ASTM D1682
Mullen Burst Strength (lbs)	190	430	ASTM D3786
Puncture Strength (lbs)	40	125	ASTM D751 Modified
Equivalent	40-80	40-80	US Std Sieve
Opening Size			CW-02215
Aggregate Depth	6	10	-

Definition & Scope

A stabilized pad of aggregate underlain with geotextile located at any point where traffic will be entering or leaving a construction site to or from a public right-of-way, street, alley, sidewalk, or parking area. The purpose of stabilized construction access is to reduce or eliminate the tracking of sediment onto public rights-of-way or streets.

Conditions Where Practice Applies

A stabilized construction access shall be used at all points of construction ingress and egress.

Design Criteria

See Figure 2.1 on page 2.31 for details.

Aggregate Size: Use a matrix of 1-4 inch stone, or reclaimed or recycled concrete equivalent.

Thickness: Not less than six (6) inches.

Width: 12-foot minimum but not less than the full width of points where ingress or egress occurs. 24-foot minimum if there is only one access to the site.

Length: As required, but not less than 50 feet (except on a single residence lot where a 30 foot minimum would apply).

Geotextile: To be placed over the entire area to be covered with aggregate. Filter cloth will not be required on a single-family residence lot. Piping of surface water under entrance shall be provided as required. If piping is impossible, a mountable berm with 5:1 slopes will be permitted.

Criteria for Geotextile: The geotextile shall be woven or nonwoven fabric consisting only of continuous chain polymeric filaments or yarns of polyester. The fabric shall be

¹Light Duty Road: Area sites that have been graded to subgrade and where most travel would be single axle vehicles and an occasional multi-axle truck. Acceptable materials are Trevira Spunbond 1115, Mirafi 100X, Typar 3401, or equivalent.

²Heavy Duty Road: Area sites with only rough grading, and where most travel would be multi-axle vehicles. Acceptable materials are Trevira Spunbond 1135, Mirafi 600X, or equivalent.

³Fabrics not meeting these specifications may be used only when design procedure and supporting documentation are supplied to determine aggregate depth and fabric strength.

Maintenance

The access shall be maintained in a condition which will prevent tracking of sediment onto public rights-of-way or streets. This may require periodic top dressing with additional aggregate. All sediment spilled, dropped, or washed onto public rights-of-way must be removed immediately.

When necessary, wheels must be cleaned to remove sediment prior to entrance onto public rights-of-way. When washing is required, it shall be done on an area stabilized with aggregate, which drains into an approved sediment-trapping device. All sediment shall be prevented from entering storm drains, ditches, or watercourses.

Figure 2.1
Stabilized Construction Access

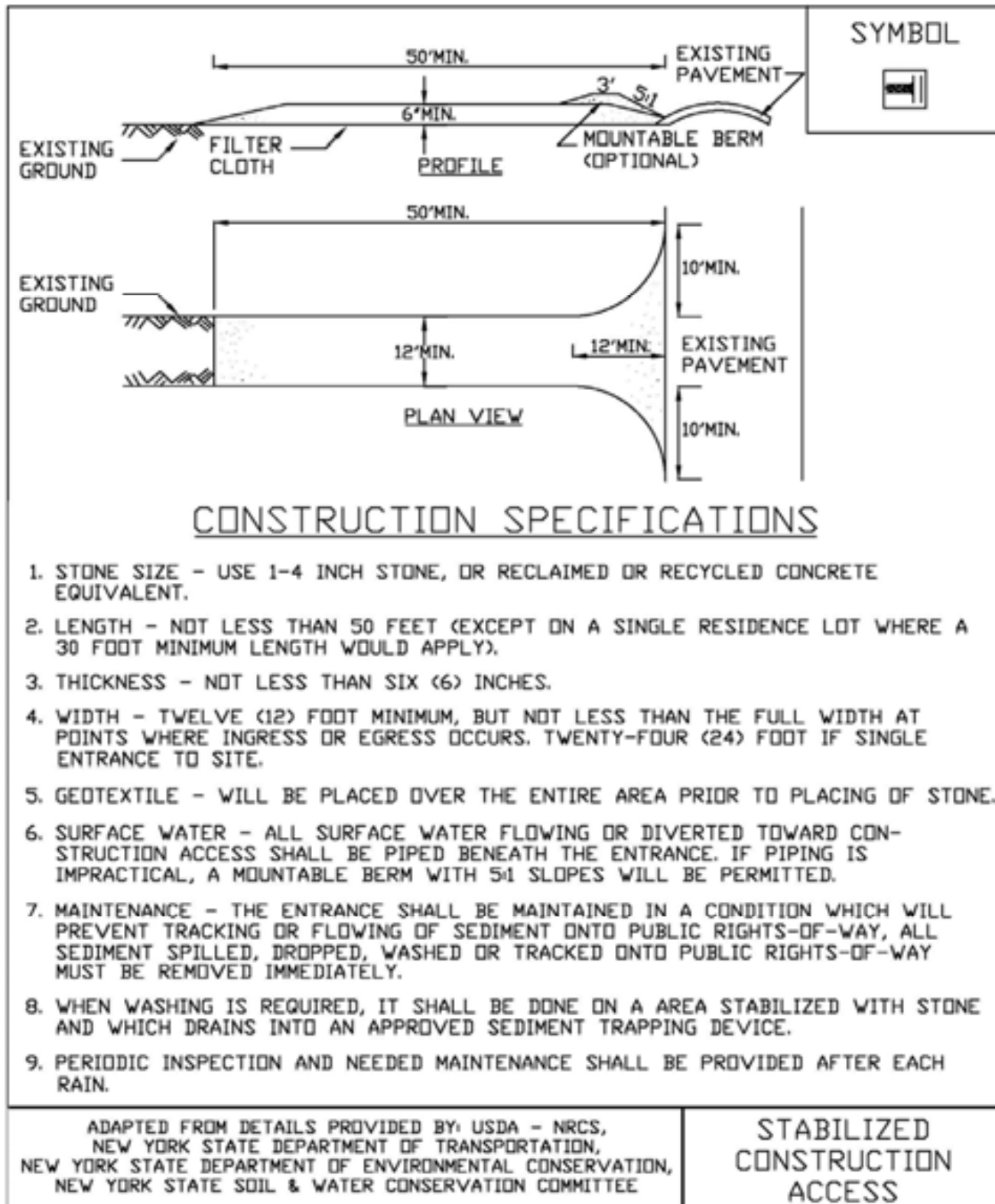

STANDARD AND SPECIFICATIONS FOR TEMPORARY ACCESS WATERWAY CROSSING



Definition & Scope

A temporary access waterway crossing is a structure placed across a waterway to provide access for construction purposes for a period of less than one year. Consideration should be given to stream flow capacity and velocity anticipated during the period of time that the temporary structures will be in place. Temporary access crossings shall not be utilized to maintain traffic for the general public. The purpose of the temporary access waterway crossing is to provide safe, environmentally sound access across a waterway for construction equipment by establishing minimum standards and specifications for the design, construction, maintenance, and removal of the structure. This standard and specification may represent a channel constriction, thus, the temporary nature of waterway access crossing must be stressed. They should be planned to be in service for the shortest practical period of time and removed as soon as their function is completed.

Conditions Where Practice Applies

This standard and specification for temporary access waterway crossings is applicable in non-tidal waterways. It provides designs based on waterway geometry rather than the drainage area contributing to the point of crossing.

The principal consideration for development of the standard and specifications is concern for erosion and sediment control, tracking soil into waterways, blocking fish passage and destruction of aquatic habitat. Structural utility and safety must also be considered when designing temporary access waterway crossings to withstand expected loads.

The three types of standard temporary access

waterway crossings are bridges, culverts, and fords.

General Requirements

1. **In-Stream Excavation:** In-Stream excavation shall be limited to only that necessary to allow installation of the standard methods as presented in Subsection “Temporary Access Waterway Crossing Methods.”
2. **Elimination of Fish Migration Barriers:** Of the two basic methods presented in Subsection “Temporary Access Waterway Crossing Methods,” bridges pose the least potential for creating barriers to aquatic migration. The construction of any specific crossing method as presented in Subsection “Temporary Access Waterway Crossing Methods,” shall not cause a significant water level difference between the upstream and downstream water surface elevations. Fish spawning or migration within waterways generally occurs between October 1 to May 31 for water classified for trout and from March 15 to July 15 for other streams. Fish spawning or migration dates can vary across New York and restrictions imposed by the NYS Department of Environmental Conservation may vary and must be checked.
3. **Crossing Alignment:** The temporary waterway crossing shall be at right angles to the stream. Where approach conditions dictate, the crossing may vary 15 degrees from a line drawn perpendicular to the centerline of the stream at the intended crossing location.
4. **Road Approaches:** The centerline of both roadway approaches shall coincide with the crossing alignment centerline for a minimum distance of 50 feet from each bank of the waterway being crossed. If physical or right-of-way restraints preclude the 50 feet minimum, a shorter distance may be provided. All fill materials associated with the roadway approach shall be limited to a maximum height of 2 feet above the existing flood plain elevation.
5. **Surface Water Diverting Structure:** A water diverting structure such as a swale shall be constructed (across the roadway on both roadway approaches) 50 feet (maximum) on either side of the waterway crossing. This will prevent roadway surface runoff from directly entering the waterway. The 50 feet is measured from the top of the waterway bank. Design criteria for this diverting structure shall be in accordance with the “Standard and Specification” for

the individual design standard of choice. If the roadway approach is constructed with a reverse grade away from the waterway, a separate diverting structure is not required.

6. **Road Width:** All crossings shall have one traffic lane. The minimum width shall be 12 feet with a maximum width of 20 feet.

7. **Time of Operation:** All temporary crossing shall be removed within 14 calendar days after the structure is no longer needed. Unless prior written approval is obtained, all structures shall be removed within one year from the date of the installation.

8. **Materials**

A. **Aggregate:** There shall be no earth or soil materials used for construction within the waterway channel. NYS DOT specifications for coarse aggregate designation No. 4 (2" to 4"), also referenced as AASHTO designation No. 1, shall be the minimum acceptable aggregate size for temporary crossings. Larger aggregates will be allowed.

B. **Filter Cloth:** Filter cloth is a fabric consisting of either woven or nonwoven plastic, polypropylene, or nylon used to distribute the load, retain fines, allow increased drainage of the aggregate and reduce mixing of the aggregate with the subgrade soil. The designer shall specify the appropriate filter fabric/cloth for a specific use.

Temporary Access Waterway Crossing Methods

The following criteria for erosion and sediment control shall be considered when selecting a specific temporary access waterway crossing standard method:

1. **Site aesthetics:** Select a standard design method that will least disrupt the existing terrain of the stream reach. Consider the effort that will be required to restore the area after the temporary crossing is removed.
2. **Site location:** Locate the temporary crossing where there will be the least disturbance to the soils of the existing waterway banks. When possible, locate the crossing at a point receiving minimal surface runoff.
3. **Physical site constraints:** The physical constraints of a site may preclude the selection of one or more of the standard methods.
4. **Time of year:** The time of year may preclude the selection of one or more of the standard methods due to fish spawning or migration restrictions.

5. **Vehicular loads and traffic patterns:** Vehicular loads, traffic patterns, and frequency of crossing should be considered in choosing a specific method.

6. **Maintenance of crossing:** The standard methods will require various amounts of maintenance. The bridge method should require the least maintenance, whereas the ford method will probably require more intensive maintenance.

7. **Removal of the Structure:** Ease of removal and subsequent damage to the waterway should be primary factors in considering the choice of a standard method.

Temporary Access Bridge (Figure 2.2 on page 2.36)

A temporary access bridge is a structure made of wood, metal, or other materials, which provides access across a stream or waterway.

Considerations:

1. This is the preferred method for temporary access waterway crossings. Normally, bridge construction causes the least disturbance to the waterway bed and banks when compared to the other access waterway crossings.
2. Most bridges can be quickly removed and reused.
3. Temporary access bridges pose the least chance for interference with fish migration when compared to the other temporary access waterway crossings.
4. Span width will be limited by the length of the bridging material and weight of equipment that will drive over the temporary bridge. Spans of over 10 feet are difficult to construct.
5. **Restrictions and Permits:** A permit from the New York State Department of Environmental Conservation, Division of Environmental Permits, Regional Permit Administrator, will be needed to install and remove temporary access culverts in streams with a classification of C(T) and higher. Installation and removal may not be permitted during the period of time from the start of trout spawning until the eggs have hatched. In some instances, restrictions may also be applied to bass spawning waters.

Construction Specifications:

1. **Restriction:** Construction, use, or removal of a temporary access bridge will not normally have any time of year restrictions if construction, use, or

removal does not disturb the stream or its banks.

2. **Bridge Placement:** A temporary bridge structure shall be constructed at or above bank elevation to prevent the entrapment of floating materials and debris.

3. **Abutments:** Abutments shall be placed parallel to and on stable banks.

4. **Bridge Span:** Bridges shall be constructed to span the entire channel. If a footing, pier, or bridge support is constructed within the waterway, a stream-disturbance permit may be required.

5. **Stringers:** Stringers shall either be logs, saw timber, pre-stressed concrete beams, metal beams, or other approved materials.

6. **Deck Material:** Decking shall be of sufficient strength to support the anticipated load. All decking members shall be placed perpendicular to the stringers, butted tightly, and securely fastened to the stringers. Decking materials must be butted tightly to prevent any soil material tracked onto the bridge from falling into the waterway below.

7. **Run Planks (optional):** Run planking shall be securely fastened to the length of the span. One run plank shall be provided for each track of the equipment wheels. Although run planks are optional, they may be necessary to properly distribute loads.

8. **Curbs or Fenders:** Curbs or fenders may be installed along the outer sides of the deck. Curbs or fenders are an option, which will provide additional safety.

9. **Bridge Anchors:** Bridges shall be securely anchored at only one end using steel cable or chain. Anchoring at only one end will prevent channel obstruction in the event that floodwaters float the bridge. Acceptable anchors are large trees, large boulders, or driven steel anchors. Anchoring shall be sufficient to prevent the bridge from floating downstream and possibly causing an obstruction to the flow.

10. **Stabilization:** All areas disturbed during installation shall be stabilized within 14 calendar days of that disturbance in accordance with the Standard and Specification for Temporary Construction Area Seeding on page 4.58.

Bridge Maintenance Requirements

1. **Inspection:** Periodic inspection shall be performed by the user to ensure that the bridge, streambed, and streambanks are maintained and not damaged.

2. **Maintenance:** Maintenance shall be performed, as needed to ensure that the structure complies with the standard and specifications. This shall include removal and disposal of any trapped sediment or debris. Sediment shall be disposed of outside of the floodplain and stabilized.

Bridge Removal and Clean-Up Requirements

1. **Removal:** When the temporary bridge is no longer needed, all structures including abutments and other bridging materials shall be removed within 14 calendar days. In all cases, the bridge materials shall be removed within one year of installation.

2. **Final Clean-Up:** Final clean-up shall consist of removal of the temporary bridge from the waterway, protection of banks from erosion, and removal of all construction materials. All removed materials shall be stored outside the waterway floodplain.

3. **Method:** Removal of the bridge and clean-up of the area shall be accomplished without construction equipment working in the waterway channel.

4. **Final Stabilization:** All areas disturbed during removal shall be stabilized within 14 calendar days of that disturbance in accordance with the Standard and Specifications for Permanent Construction Area Planting on page 4.42.

Temporary Access Culvert (Figure 2.3 on page 2.37)

A temporary access culvert is a structure consisting of a section(s) of circular pipe, pipe arches, or oval pipes of reinforcing concrete, corrugated metal, or structural plate, which is used to convey flowing water through the crossing.

Considerations

1. Temporary culverts are used where a) the channel is too wide for normal bridge construction, b) anticipated loading may prove unsafe for single span bridges, or c) access is not needed from bank to bank.

2. This temporary waterway crossing method is normally preferred over a ford type of crossing, since disturbance to the waterway is only during construction and removal of the culvert.

3. Temporary culverts can be salvaged and reused.

Construction Specifications

1. **Restrictions and Permits:** A permit from the New York State Department of Environmental

Conservation, Division of Environmental Permits, Regional Permit Administrator, will be needed to install and remove temporary access culverts in streams with a classification of C(T) and higher. Installation and removal may not be permitted during the period of time from the start of trout spawning until the eggs have hatched. In some instances, restrictions may also be applied to bass spawning waters.

2. Culvert Strength: All culverts shall be strong enough to support their cross sectional area under maximum expected loads.

3. Culvert Size: The size of the culvert pipe shall be the largest pipe diameter that will fit into the existing channel without major excavation of the waterway channel or without major approach fills. If a channel width exceeds 3 feet, additional pipes may be used until the cross sectional area of the pipes is greater than 60 percent of the cross sectional area of the existing channel. The minimum size culvert that may be used is 12-inch diameter pipe.

4. Culvert Length: The culvert(s) shall extend a minimum of one foot beyond the upstream and downstream toe of the aggregate placed around the culvert. In no case shall the culvert exceed 40 feet in length.

5. Filter Cloth: Filter cloth shall be placed on the streambed and streambanks prior to placement of the pipe culvert(s) and aggregate. The filter cloth shall cover the streambed and extend a minimum six inches and a maximum one foot beyond the end of the culvert and bedding material. Filter cloth reduces settlement and improves crossing stability.

6. Culvert Placement: The invert elevation of the culvert shall be installed on the natural streambed grade to minimize interference with fish migration (free passage of fish).

7. Culvert Protection: The culvert(s) shall be covered with a minimum of one foot of aggregate. If multiple culverts are used, they shall be separated by at least 12 in. of compacted aggregate fill. At the minimum, the bedding and fill material used in the construction of the temporary access culvert crossings shall conform with the aggregate requirements cited in the General Requirements subsection.

8. Stabilization: All areas disturbed during culvert installation shall be stabilized within 14 calendar days of the disturbance in accordance with the Standard for Permanent Construction Area Plantings.

ensure that the culverts, streambed, and streambanks are not damaged, and that sediment is not entering the stream or blocking fish passage or migration.

2. Maintenance: Maintenance shall be performed, as needed in a timely manner to ensure that structures are in compliance with this standard and specification. This shall include removal and disposal of any trapped sediment or debris. Sediment shall be disposed of and stabilized outside the waterway flood plain.

Culvert Removal and Clean-Up Requirements

1. Removal: When the crossing has served its purpose, all structures, including culverts, bedding, and filter cloth materials shall be removed within 14 calendar days. In all cases, the culvert materials shall

be removed within one year of installation. No structure shall be removed during the spawning season (generally October 1 through May 31 for trout waters and March 15 through July 15 for other waters).

2. Final Clean-Up: Final clean-up shall consist of removal of the temporary structure from the waterway, removal of all construction materials, restoration of original stream channel cross section, and protection of the streambanks from erosion. Removed material shall be stored outside of the waterway floodplain.

3. Method: Removal of the structure and clean-up of the area shall be accomplished without construction equipment working in the waterway channel.

4. Final Stabilization: All areas disturbed during culvert removal shall be stabilized within 14 calendar days of the disturbance in accordance with the Standard for Permanent Construction Area Plantings.

NOTE: Any temporary access crossing shall conform to the technical requirements of this Standard and Specifications as well as any specific requirement imposed by the New York State Department of Environmental Conservation and the US Army Corps of Engineers. Permits may be required for streambank disturbance.

Culvert Maintenance Requirements

1. Inspection: Periodic inspection shall be performed to

Figure 2.2
Temporary Access Bridge

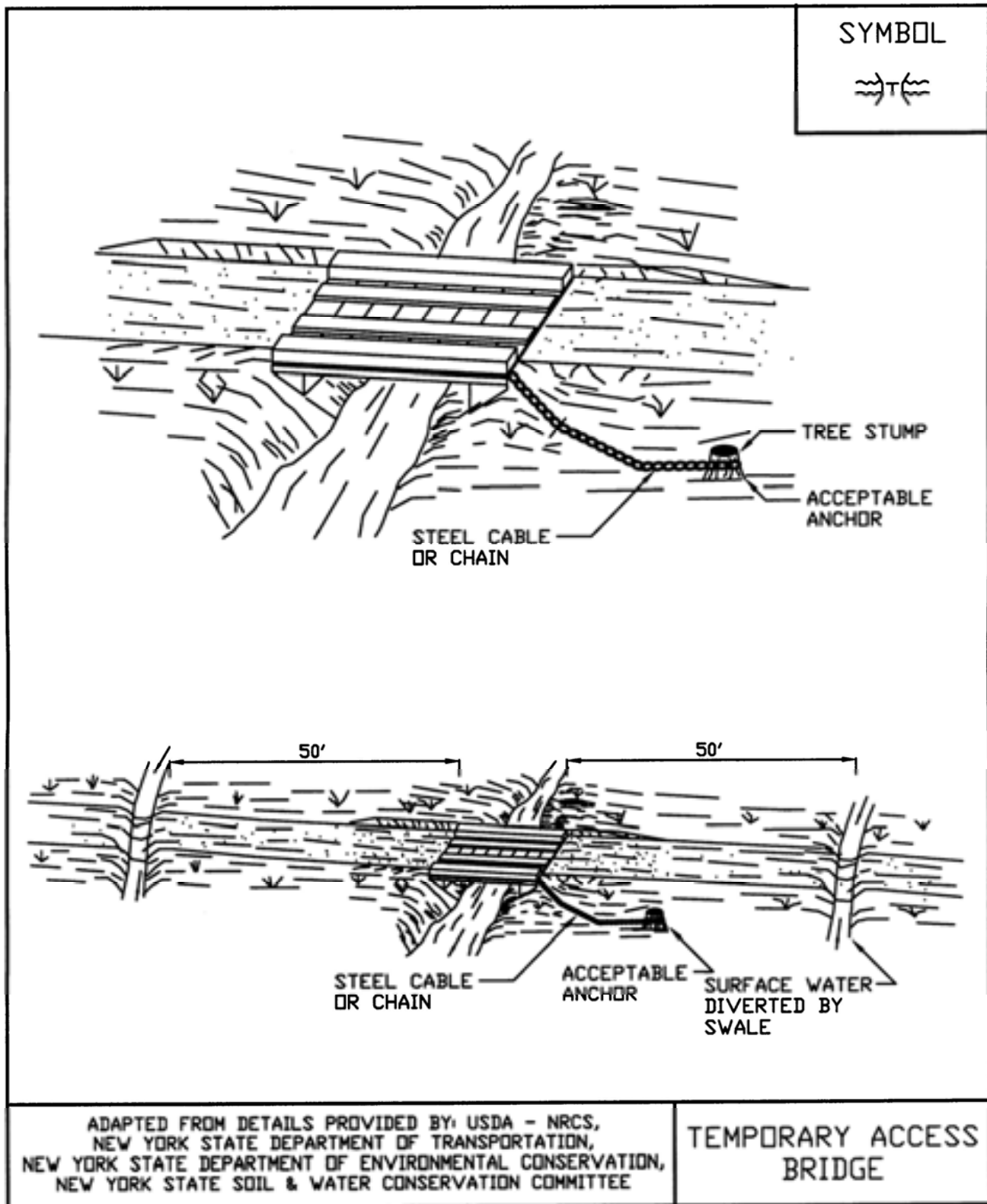
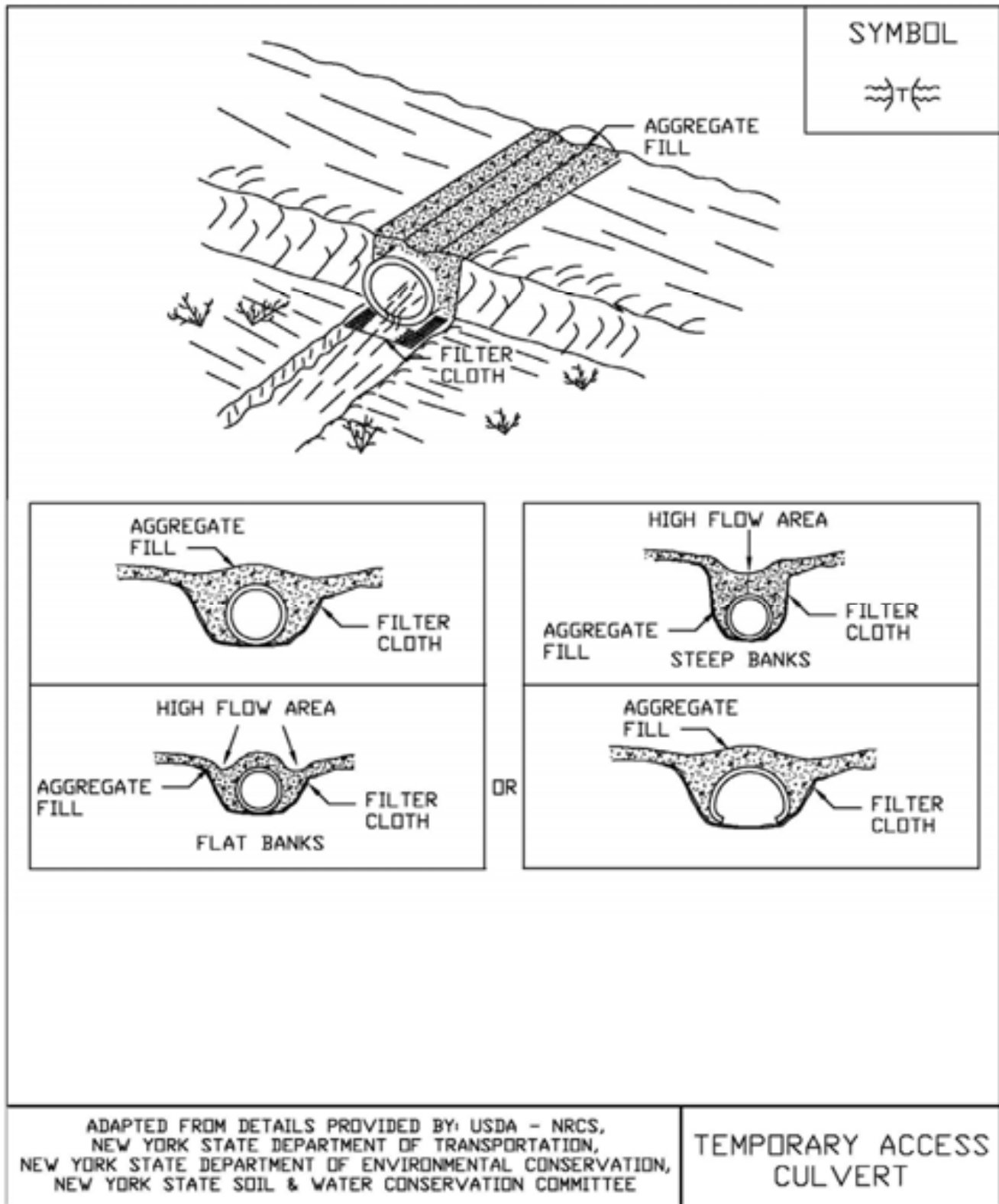

Figure 2.3
Temporary Access Culvert



STANDARD AND SPECIFICATIONS FOR WINTER STABILIZATION



Definition & Scope

A temporary site specific, enhanced erosion and sediment control plan to manage runoff and sediment at the site during construction activities in the winter months to protect off-site water resources.

Conditions Where Practice Applies

This standard applies to all construction activities involved with ongoing land disturbance and exposure between November 15th to the following April 1st.

Design Criteria

1. Prepare a snow management plan with adequate storage for snow and control of melt water, requiring cleared snow to be stored in a manner not affecting ongoing construction activities.
2. Enlarge and stabilize access points to provide for snow management and stockpiling. Snow management activities must not destroy or degrade installed erosion and sediment control practices.
3. A minimum 25 foot buffer shall be maintained from all perimeter controls such as silt fence. Mark silt fence with tall stakes that are visible above the snow pack.
4. Edges of disturbed areas that drain to a waterbody within 100 feet will have 2 rows of silt fence, 5 feet apart, installed on the contour.
5. Drainage structures must be kept open and free of snow and ice dams. All debris, ice dams, or debris from plowing operations, that restrict the flow of runoff and meltwater, shall be removed.
6. Sediment barriers must be installed at all appropriate

perimeter and sensitive locations. Silt fence and other practices requiring earth disturbance must be installed before the ground freezes.

7. Soil stockpiles must be protected by the use of established vegetation, anchored straw mulch, rolled stabilization matting, or other durable covering. A barrier must be installed at least 15 feet from the toe of the stockpile to prevent soil migration and to capture loose soil.
8. In areas where soil disturbance activity has temporarily or permanently ceased, the application of soil stabilization measures should be initiated by the end of the next business day and completed within three (3) days. Rolled erosion control blankets must be used on all slopes 3 horizontal to 1 vertical or steeper.
9. If straw mulch alone is used for temporary stabilization, it shall be applied at double the standard rate of 2 tons per acre, making the application rate 4 tons per acre. Other manufactured mulches should be applied at double the manufacturer's recommended rate.
10. To ensure adequate stabilization of disturbed soil in advance of a melt event, areas of disturbed soil should be stabilized at the end of each work day unless:
 - a. work will resume within 24 hours in the same area and no precipitation is forecast or;
 - b. the work is in disturbed areas that collect and retain runoff, such as open utility trenches, foundation excavations, or water management areas.
11. Use stone paths to stabilize access perimeters of buildings under construction and areas where construction vehicle traffic is anticipated. Stone paths should be a minimum 10 feet in width but wider as necessary to accommodate equipment.

Maintenance

The site shall be inspected frequently to ensure that the erosion and sediment control plan is performing its winter stabilization function. If the site will not have earth disturbing activities ongoing during the "winter season", **all** bare exposed soil must be stabilized by established vegetation, straw or other acceptable mulch, matting, rock, or other approved material such as rolled erosion control products. Seeding of areas with mulch cover is preferred but seeding alone is not acceptable for proper stabilization.

Compliance inspections must be performed and reports filed properly in accordance with the SWPPP for all sites under a winter shutdown.

STANDARD AND SPECIFICATIONS FOR CHECK DAM



Definition & Scope

Small barriers or dams constructed of stone, bagged sand or gravel, or other durable materials across a drainageway to reduce erosion in a drainage channel by reducing the velocity of flow in the channel.

Conditions Where Practice Applies

This practice is used as a **temporary** and, in some cases, a **permanent** measure to limit erosion by reducing velocities in open channels that are degrading or subject to erosion or where permanent stabilization is impractical due to short period of usefulness and time constraints of construction.

Design Criteria

Drainage Area: Maximum drainage area above the check dam shall not exceed two (2) acres.

Height: Not greater than 2 feet. Center shall be maintained 9 inches lower than abutments at natural ground elevation.

Side Slopes: Shall be 2:1 or flatter.

Spacing: The check dams shall be spaced as necessary in the channel so that the crest of the downstream dam is at the elevation of the toe of the upstream dam. This spacing is equal to the height of the check dam divided by the channel slope.

Therefore:
$$S = \frac{h}{s}$$

Where: S = spacing interval (ft.)
h = height of check dam (ft.)
s = channel slope (ft./ft.)

Example:

For a channel with and 2 ft. high stone they are spaced as
$$S = \frac{2 \text{ ft}}{0.04 \frac{\text{ft}}{\text{ft}}} = 50 \text{ ft}$$
 a 4% slope check dams, follows:

For stone check dams: Use a well graded stone matrix 2 to 9 inches in size (NYS – DOT Light Stone Fill meets these requirements).

The overflow of the check dams will be stabilized to resist erosion that might be caused by the check dam. See Figure 3.1 on page 3.3 for details.

Check dams should be anchored in the channel by a cutoff trench 1.5 ft. wide and 0.5 ft. deep and lined with filter fabric to prevent soil migration.

For filter sock or fiber roll check dams: The check dams will be anchored by staking the dam to the earth contact surface. The dam will extend to the top of the bank. The check dam will have a splash apron of NYS DOT #2 crushed stone extending a minimum 3 feet downstream from the dam and 1 foot up the sides of the channel. The compost and materials for a filter sock check dam shall meet the requirements shown in the standard for Compost Filter Sock on page 5.7.

Maintenance

The check dams should be inspected after each runoff event. Correct all damage immediately. If significant erosion has occurred between structures, a liner of stone or other suitable material should be installed in that portion of the channel or additional check dams added.

Remove sediment accumulated behind the dam as needed to allow channel to drain through the stone check dam and prevent large flows from carrying sediment over the dam.

Figure 3.1
Stone Check Dam Detail

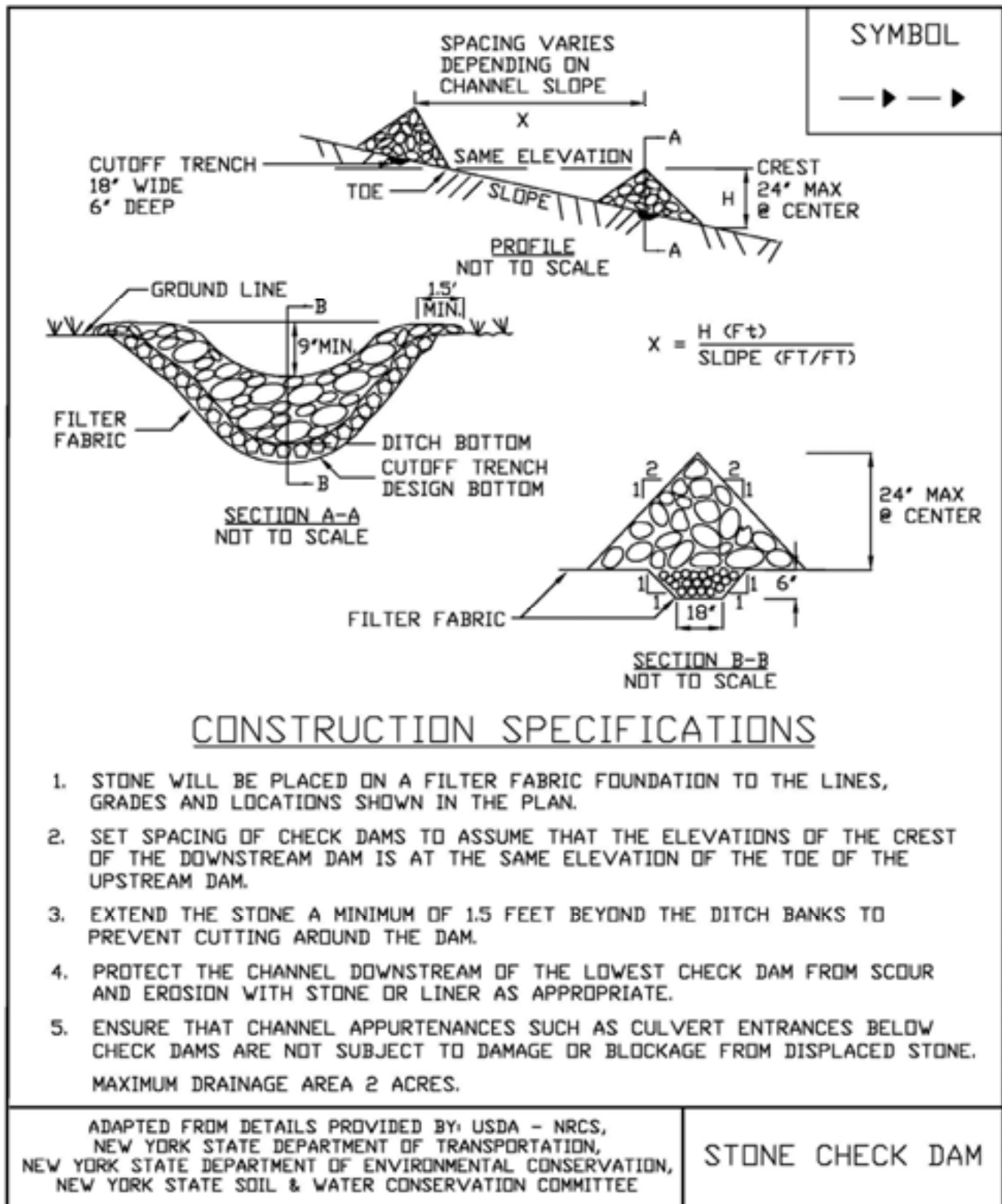

STANDARD AND SPECIFICATIONS FOR CONSTRUCTION DITCH



Definition & Scope

A **temporary** excavated drainage way to intercept sediment laden water and divert it to a sediment trapping device or to prevent runoff from entering disturbed areas by intercepting and diverting it to a stabilized outlet.

Conditions Where Practice Applies

Construction ditches are constructed:

1. to divert flows from entering a disturbed area.
2. intermittently across disturbed areas to shorten over-land flow distances.
3. to direct sediment laden water along the base of slopes to a trapping device.
4. to transport offsite flows across disturbed areas such as rights-of-way.

Ditches collecting runoff from disturbed areas shall remain in place until the disturbed areas are permanently stabilized.

Design Criteria

See Figure 3.2 on page 3.6 for details.

General

	Ditch A	Ditch B
Drainage Area	<5 Ac	5-10 Ac
Bottom Width of Flow Channel	4 ft.	6 ft.
Depth of Flow Channel	1 ft.	1 ft.
Side Slopes	2:1 or flatter	2:1 or flatter
Grade	0.5% Min. 10% Max.	0.5% Min. 10% Max.

For drainage areas larger than 10 acres, refer to the Standard and Specification for Grassed Waterways on page 3.23 and 3.24.

Stabilization

Stabilization of the ditch shall be completed within 2 days of installation in accordance with the appropriate standard and specifications for vegetative stabilization or stabilization with mulch as determined by the time of year. The flow channel shall be stabilized as per the following criteria:

The seeding for vegetative stabilization shall be in accordance with the standard on Page 4.78. The seeded area will be mulched in accordance with the standard on Page 4.39.

Type of Treatment	Channel Grade ¹	Flow Channel	
		A (<5 Ac.)	B (5-10 Ac.)
1	0.5-3.0%	Seed & Straw Mulch	Seed & Straw Mulch
2	3.1-5.0%	Seed & Straw Mulch	Seed and cover with RECP ² , Sod, or lined with plastic or 2" stone
3	5.1-8.0%	Seed and cover with RECP ² , Sod, or line with plastic or 2 in. stone	Line with 4-8 in. rip-rap or, geotextile
4	8.1-10%	Line with 4-8 in. rip-rap or geotextile	Site Specific Design

1 In highly erodible soils, as defined by the local approving agency, refer to the next higher slope grade for type of stabilization.
2 Rolled Erosion Control Product.

Outlet

Ditch shall have an outlet that functions with a minimum of erosion, and dissipates runoff velocity prior to discharge off the site.

Runoff shall be conveyed to a sediment trapping device such as a sediment trap or sediment basin until the drainage area above the ditch is adequately stabilized.

The on-site location may need to be adjusted to meet field conditions in order to utilize the most suitable outlet condition.

If a ditch is used to divert clean water flows from entering a disturbed area, a sediment trapping device may not be needed.

**Figure 3.2
Construction Ditch Detail**

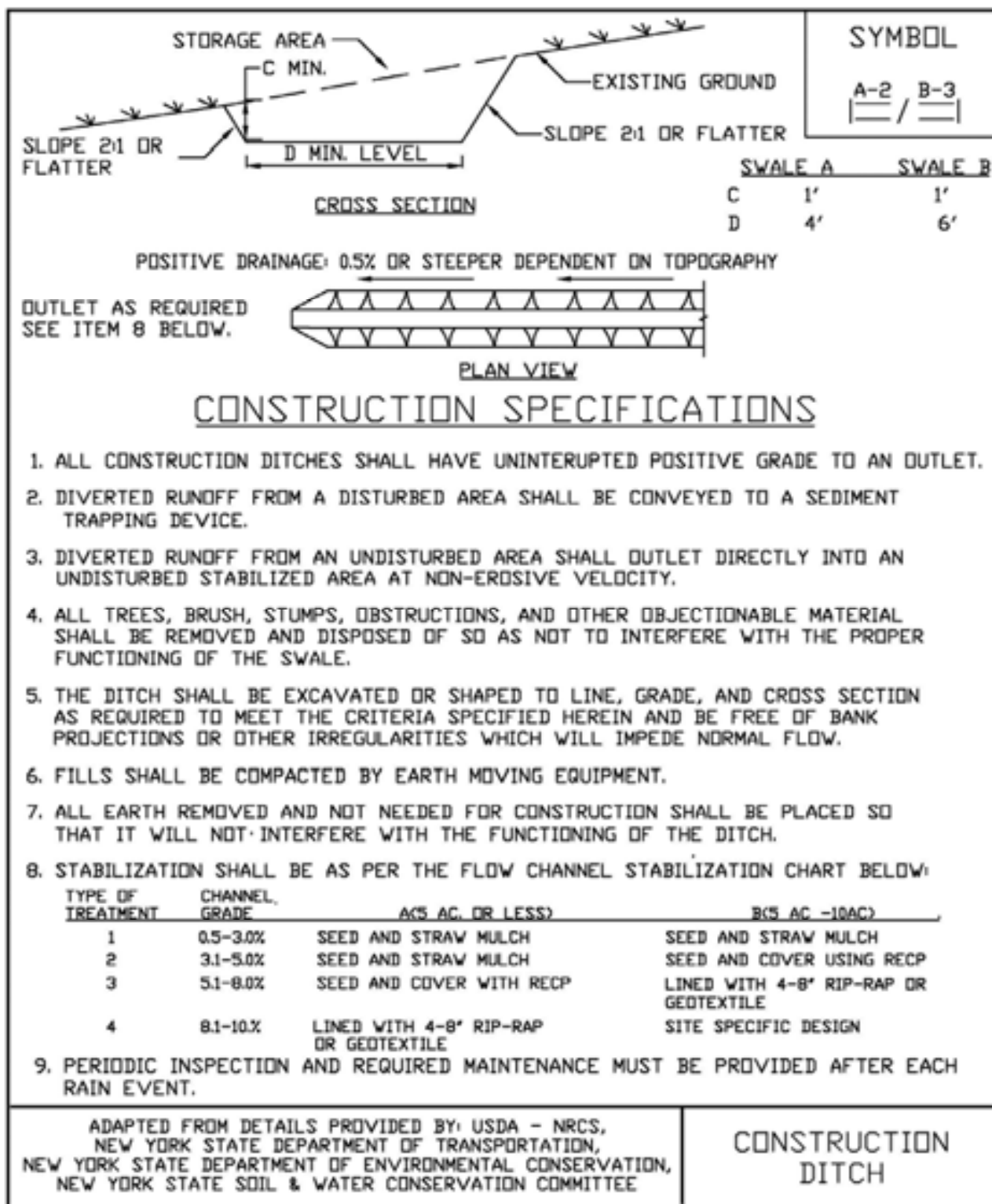

STANDARD AND SPECIFICATIONS FOR DEWATERING SUMP PIT



Discharge of turbid water pumped from the standpipe should be to a sediment trap, sediment basin, filter bag or stabilized area, such as a filter strip. If water from the sump pit will be pumped directly to a storm drain system, filter cloth with an equivalent sieve size between 40-80 should be wrapped around the standpipe to ensure clean water discharge. It is recommended that $\frac{1}{4}$ to $\frac{1}{2}$ inch hardware cloth be wrapped around and secured to the standpipe prior to attaching the filter cloth. This will increase the rate of water seepage into the standpipe.

Definition & Scope

A **temporary** pit which is constructed using pipe and stone for pumping excessive water from excavations to a suitable discharge area.

Conditions Where Practice Applies

Sump pits are constructed when water collects during the excavation phase of construction. This practice is particularly useful in urban areas during excavation for building foundations. It may also be necessary during construction activities that encounter high ground water tables in floodplain locations.

Design Criteria

The number of sump pits and their locations shall be determined by the contractor/engineer. A design is not required, but construction should conform to the general criteria outlined on Figure 3.3 on page 3.8.

A perforated vertical standpipe is placed in the center of the pit and surrounded with a stone screening material to collect filtered water. Water is then pumped from the center of the pipe to a suitable discharge area.



**Figure 3.3
Dewatering Sump Pit Detail**

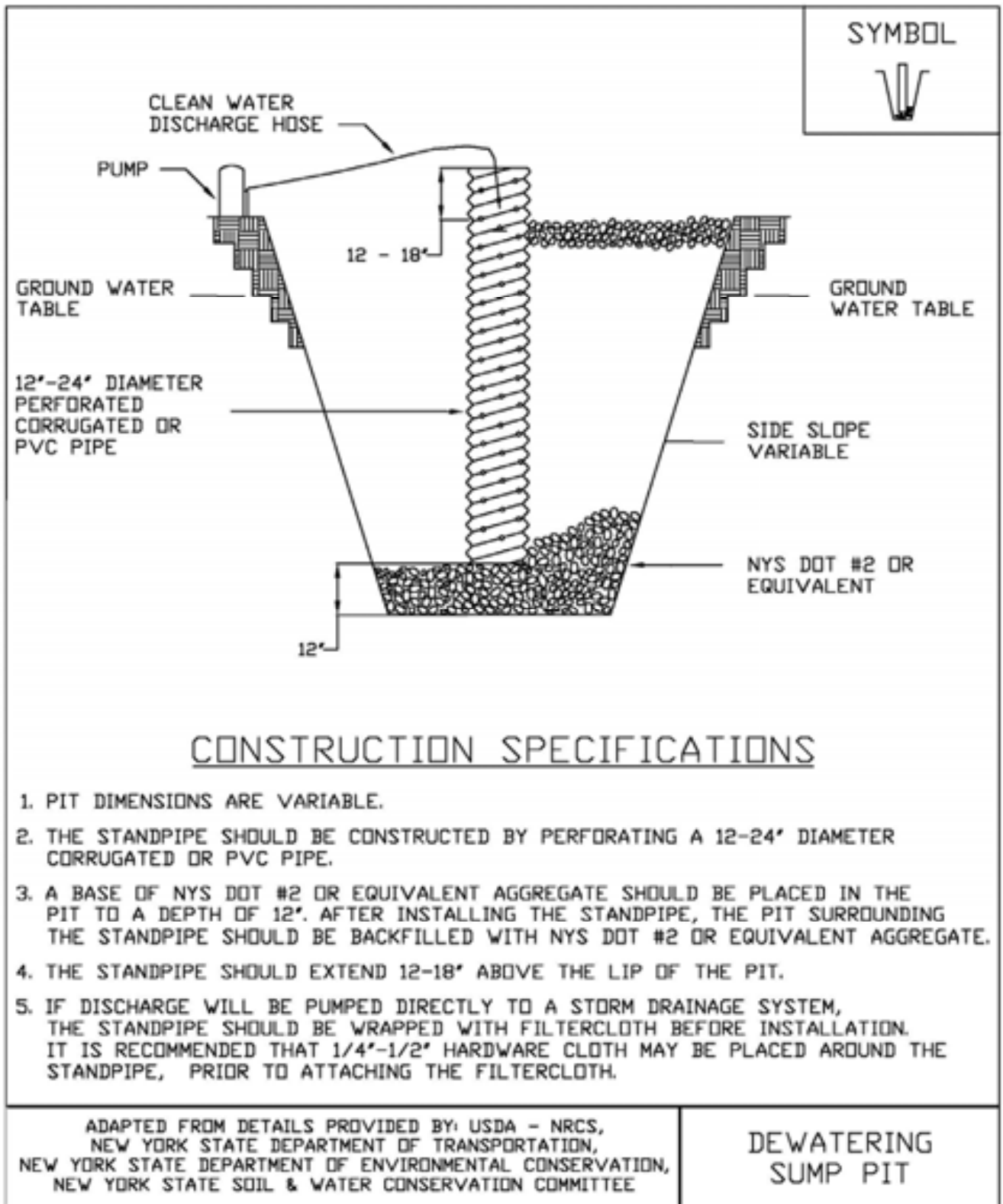

STANDARD AND SPECIFICATIONS FOR FLOW DIFFUSER



Definition & Scope

A permanent non-erosive outlet for concentrated runoff constructed to diffuse flow uniformly through a stone matrix onto a stabilized area in the form of shallow, low velocity, sheet flow.

Conditions Where Practice Applies

Where sediment-free stormwater runoff can be released in low velocity sheet flow down stabilized areas without causing erosion; where the ground slope at the outlet of the diffuser is less than 30% and the runoff will not re-concentrate after release; and where construction of a flow spreader is not practicable.

Design Criteria

1. **Drainage area:** The maximum drainage area to the diffuser may not exceed 0.10 acre per foot length of the flow diffuser. The drainage area served by the diffuser discharging directly cannot be 10-20% more than half the size of the receiving buffer area.
2. **Discharge from diffuser onto receiving area:** The peak stormwater flow rate from a flow diffuser onto a receiving area from a 10-year 24-hour storm must be less than 0.25 cubic feet per second (0.25 cfs) per linear foot of weir crest length.
3. **Receiving area of buffer:** Each flow diffuser shall have a vegetated receiving area with a minimum continuous length of 150 feet and the capacity to pass the flow without erosion. The receiving area shall be stable prior to the construction of the flow diffuser. The receiving area shall have topography regular enough to

prevent undue flow concentration before entering a stable watercourse but it shall have a slope that is less than 30%. If the receiving area is not presently stable, then the receiving area shall be stabilized prior to construction of the flow diffuser. The receiving area below the flow diffuser shall be protected from harm during construction. Sodding and/or turf reinforcement mat (TRM) in combination with vegetative measures shall stabilize disturbed areas. The receiving area shall not be used by the flow diffuser until stabilization has been accomplished. A temporary diversion may be necessary in this case.

4. **Cross-section:** The minimum stone diffuser cross-section shall be trapezoidal with a height of 1 foot above natural ground; top width equal to 2 foot and side slope equal to 1 horizontal to 1 vertical. The storage area behind the diffuser shall be excavated to a depth of 1 foot and overall width of storage area equal to 6 feet minimum.
5. **Sizing the diffuser:** The length of the stone diffuser is governed by the size of the stone in the structure, the height of the diffuser, and the flow length through it. The following equation is used to establish the design of the diffuser:

$$Q_d = \frac{h^{3/2} W}{\left[\left(\frac{L}{D}\right) + 2.5 + L^2\right]^{0.5}}$$

Where:

Q_d = Outflow through the stone diffuser (cfs)

h = Ponding depth behind the diffuser (ft.)

W = Linear length of the diffuser along centerline (ft.)

L = Average horizontal flow length through the diffuser perpendicular to the centerline (ft.)

D = Average stone diameter (d_{50}) in the structure (ft.)

The maximum d_{50} size shall be 9" or 0.75'.

The designer shall calculate the length of diffuser needed depending on the geometry of the cross-section and rock size to be used recognizing that the maximum allowable discharge through the diffuser shall be 0.25 cfs per foot of length.

Once the discharge is calculated for the 10 year storm for the drainage area to the diffuser (Q_{10}) it can be divided by the design discharge of the diffuser to determine the diffuser length as follows:

$$W = \frac{Q_{10}}{Q_d}$$

Where:

Q_d = Outflow through the stone diffuser (cfs/ft)

Q_{10} = Discharge rate for the 10 year storm (cfs)

W = Linear length of the diffuser along centerline (ft.)

Design examples are shown in Appendix B.

Figure 3.6
Flow Diffuser Detail

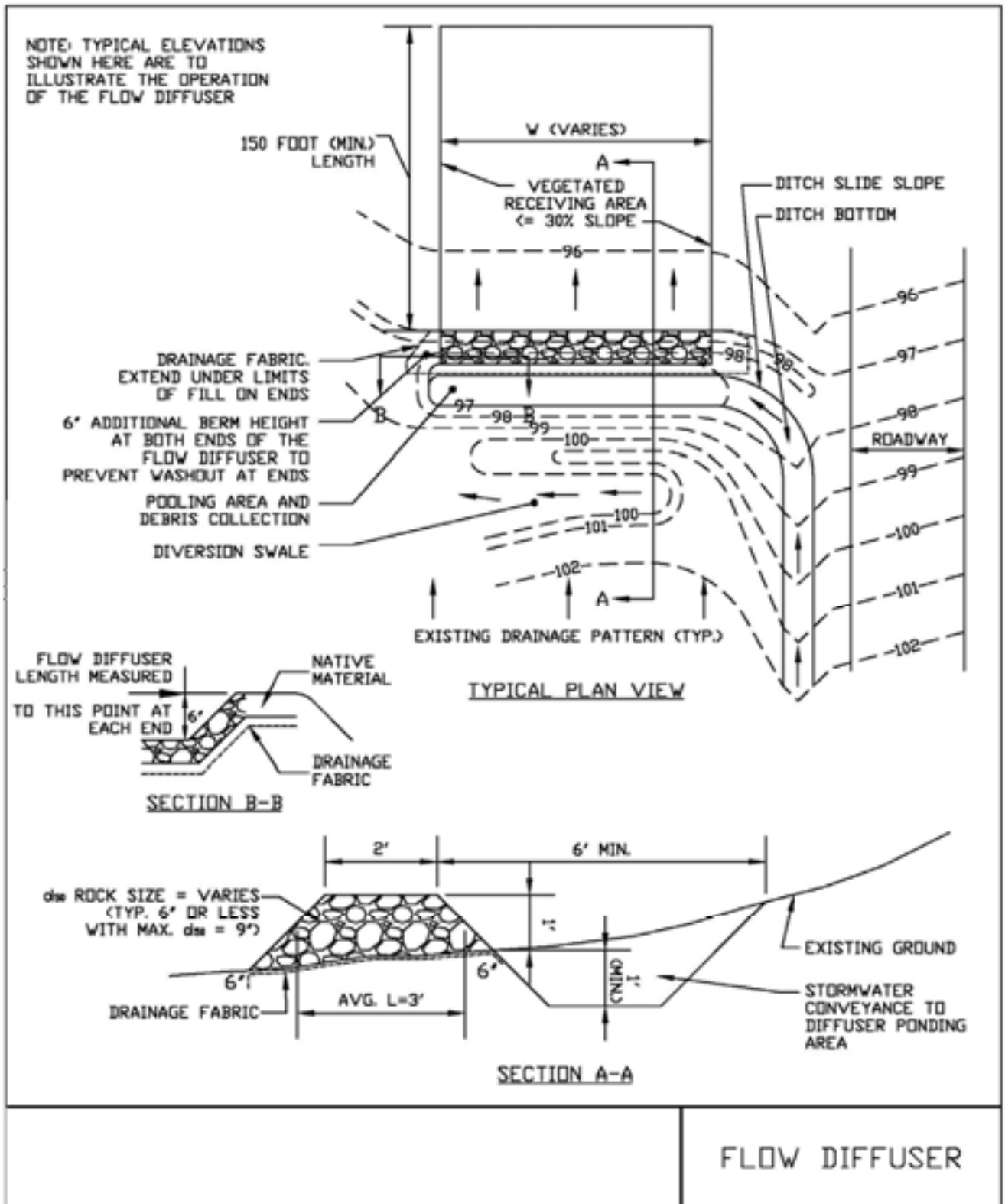

STANDARD AND SPECIFICATIONS FOR FLOW SPREADER



Definition & Scope

A **permanent or temporary**, non-erosive outlet for concentrated runoff, constructed to disperse concentrated flow uniformly over a hardened weir into a stabilized area as shallow, low velocity, sheet flow.

Conditions Where Practice Applies

Where sediment-free storm runoff can be released in sheet flow down a stabilized slope without causing erosion; where a hardened level weir can be constructed without filling; where the area below the weir is uniform with a slope of 10% or less and the runoff will not re-concentrate after release; and where no traffic will disturb the flow spreader.

Design Criteria

1. **Drainage area:** The maximum drainage area to the spreader may not exceed 5 acres.
2. **Discharge to a flow spreader:** The peak stormwater flow rate to a flow spreader due to runoff from a 10-year 24-hour storm must be less than 0.5 cubic feet per second (0.5 cfs) per foot length of flow spreader lip.
3. **Length of flow spreader:** The flow spreader length may not be more than 30 feet if flow is entering from one end of the spreader. Longer lengths require flow to split evenly from the center of the spreader.
4. **Receiving area of buffer:** Each flow spreader shall have a vegetated receiving area with the capacity to pass the flow without erosion. The receiving area shall be stable prior to the construction of the flow spreader. The receiving area shall have topography regular enough to prevent undue flow concentration before entering a stable watercourse but it shall have a slope that is less than 10%. If the receiving area is not presently stable, then the receiving area shall be stabilized prior to construction of the flow spreader. The receiving area below the flow spreader shall be protected from harm during construction. Sodding and/or turf reinforced mat in combination with vegetative measures shall stabilize disturbed areas. The receiving area shall not be used by the flow spreader until stabilization has been accomplished. A temporary diversion may be necessary in this case.
5. **Weir:** The weir of the flow spreader should consist of a pressure treated 2"x12" timber plank laid on edge and set at level elevation perpendicular to flow. Alternate hardened weir structures may be used as long as a hard, durable, continuous weir is maintained.
6. **Channel:** The flow spreader entrance channel shall be a minimum of 1 foot deep with a minimum 2 foot bottom width to trap sediment and reduce lateral flow velocities. Side slopes shall be 2:1 or flatter. The channel shall be constructed with a 0% grade to ensure uniform flow distribution. Velocity entering the channel shall be reduced to ensure non-erosive low approach velocity in the weir.
7. **Maintenance:** Long term maintenance of the flow spreader is essential to ensure its continued effectiveness. The following provisions should be followed. In the first year the flow spreader should be inspected semi annually and following major storm events for any signs of channelization and should be immediately repaired. After the first year, annual inspection should be sufficient. Spreaders constructed of wood, asphalt, stone or concrete curbing require periodic inspection to check for damage and to be repaired as needed.
 - A. **Inspections:** At least once a year, the spreader pool should be inspected for sand accumulation and debris that may reduce capacity.
 - B. **Maintenance Access:** Flow spreaders should be sited to provide easy access for removal of accumulated sediment and rehabilitation of the berm.
 - C. **Debris Removal:** Debris buildup within the channel should be removed when it has accumulated to approximately 10 to 20% of design volume or channel capacity. Remove debris such as leaf litter, branches, tree growth and any sediment build-up from the spreader and dispose of appropriately.
 - D. **Mowing:** Vegetated spreaders may require mowing.

Figure 3.7
Flow Spreader Detail

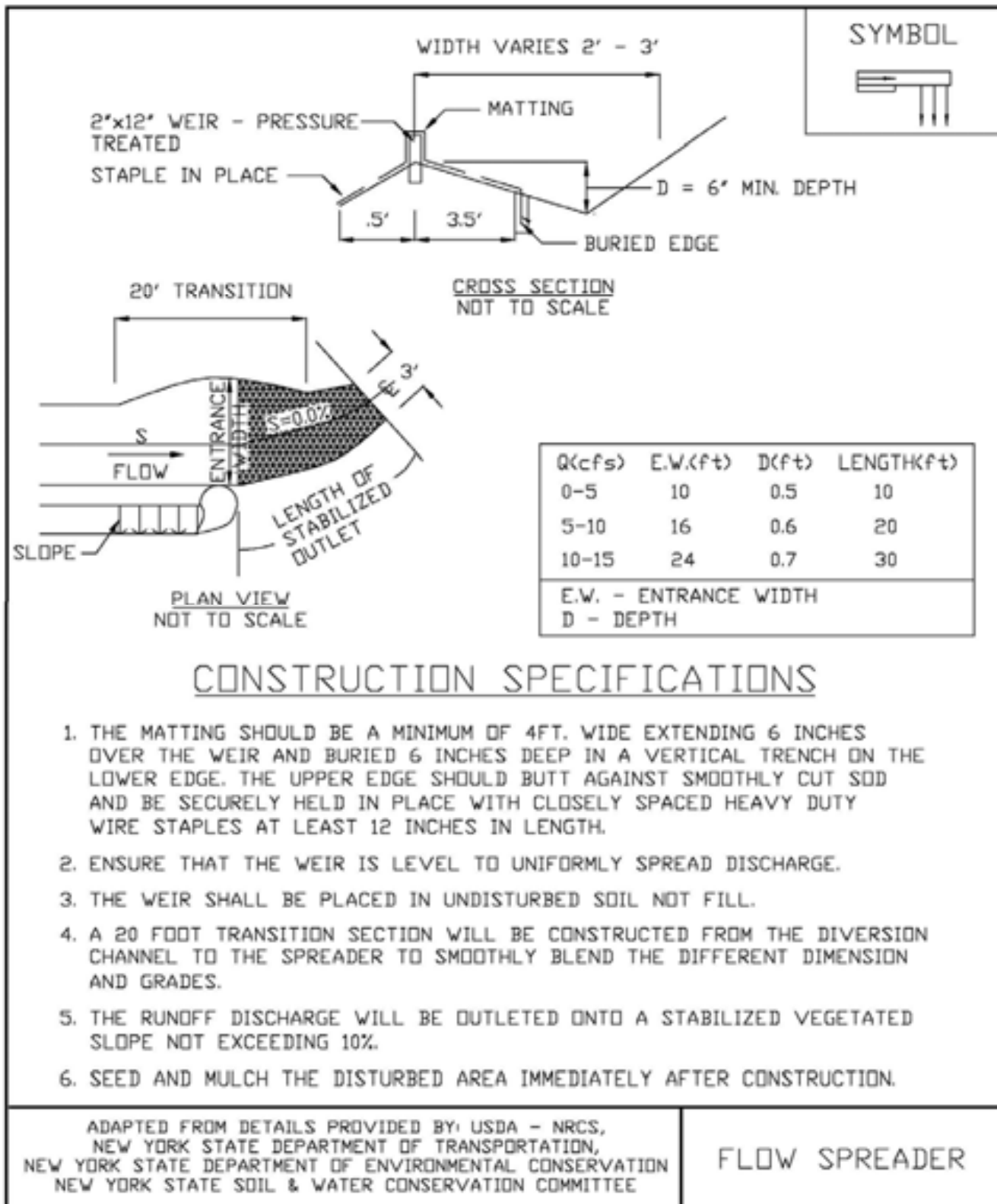

STANDARD AND SPECIFICATIONS FOR GRASSED WATERWAY



Definition & Scope

A natural or **permanent** man-made channel of parabolic or trapezoidal cross-section that is below adjacent ground level and is stabilized by suitable vegetation. The flow channel is normally wide and shallow and conveys the runoff down the slope without causing damage by erosion.

Conditions Where Practice Applies

Grass waterways are used where added vegetative protection is needed to control erosion resulting from concentrated runoff.

Design Criteria

Capacity

The minimum capacity shall be that required to confine the peak rate of runoff expected from a 10-year 24 hour frequency rainfall event or a higher frequency corresponding to the hazard involved. This requirement for confinement may be waived on slopes of less than one (1) percent where out-of-bank flow will not cause erosion or property damage.

Peak rates of runoff values used in determining the capacity requirements shall be computed by appropriate methods. Where there is base flow, it shall be handled by a stone center, subsurface drain, or other suitable means since sustained wetness usually prevents adequate vegetative cover. The cross-sectional area of the stone center or subsurface drain size to be provided shall be determined by using a flow rate of 0.1 cfs/acre or by actual measurement of the maximum base flow.

Velocity

Please see Table 3.1, Diversion Maximum Permissible Design Velocities on page 3.10, for seed, soil, and velocity variables.

Cross Section

The design water surface elevation of a grassed waterway receiving water from diversions or other tributary channels shall be equal to or less than the design water surface elevation in the diversion or other tributary channels.

The top width of parabolic waterways shall not exceed 30 feet and the bottom width of trapezoidal waterways shall not exceed 15 feet unless multiple or divided waterways, stone center, or other means are provided to control meandering of low flows.

Structural Measures

In cases where grade or erosion problems exist, special control measures may be needed such as lined waterways (see page 3.27), or grade stabilization measures (see page 3.21). Where needed, these measures will be supported by adequate design computations. For typical cross sections of waterways with riprap sections or stone centers, refer to Figure 3.8 on page 3.24.

The design procedures for parabolic and trapezoidal channels are available in the NRCS Engineering Field Handbook. Figure 3.9 on page 3.25 also provides a design chart for parabolic waterway.

Outlets

Each waterway shall have a stable outlet. The outlet may be another waterway, a stabilized open channel, grade stabilization structure, etc. In all cases, the outlet must discharge in such a manner as not to cause erosion. Outlets shall be constructed and stabilized prior to the operation of the waterway.

Stabilization

Waterways shall be stabilized in accordance with the appropriate vegetative stabilization standard and specifications, and will be dependent on such factors as slope, soil class, etc. See standard for Vegetating Waterways on Page 4.78.

Construction Specifications

See Figure 3.10 on page 3.26 for details.

Figure 3.8
Typical Waterway Cross Sections Details

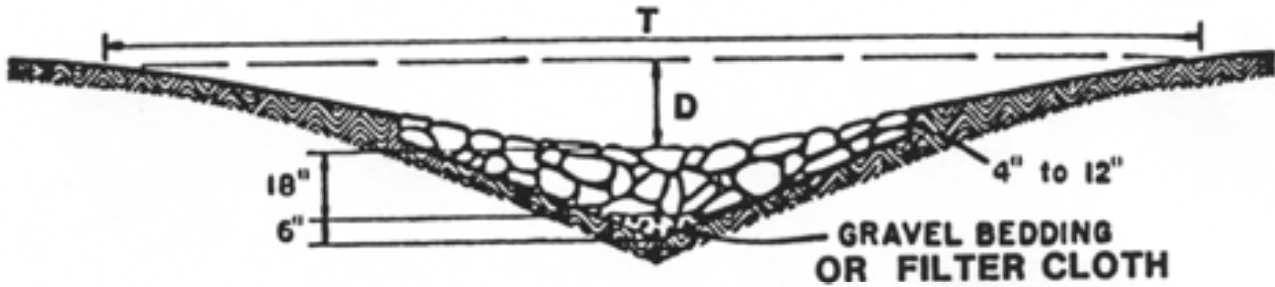

Waterway with stone center drain. "V" section shaped by motor grader.

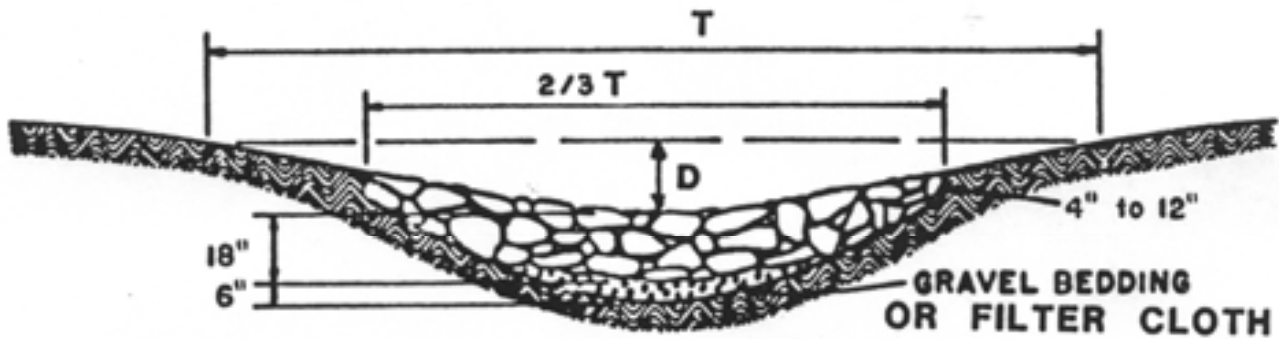

Waterway with stone center drain. Rounded section shaped by bulldozer.

Figure 3.9
Parabolic Waterway Design Chart (USDA - NRCS)

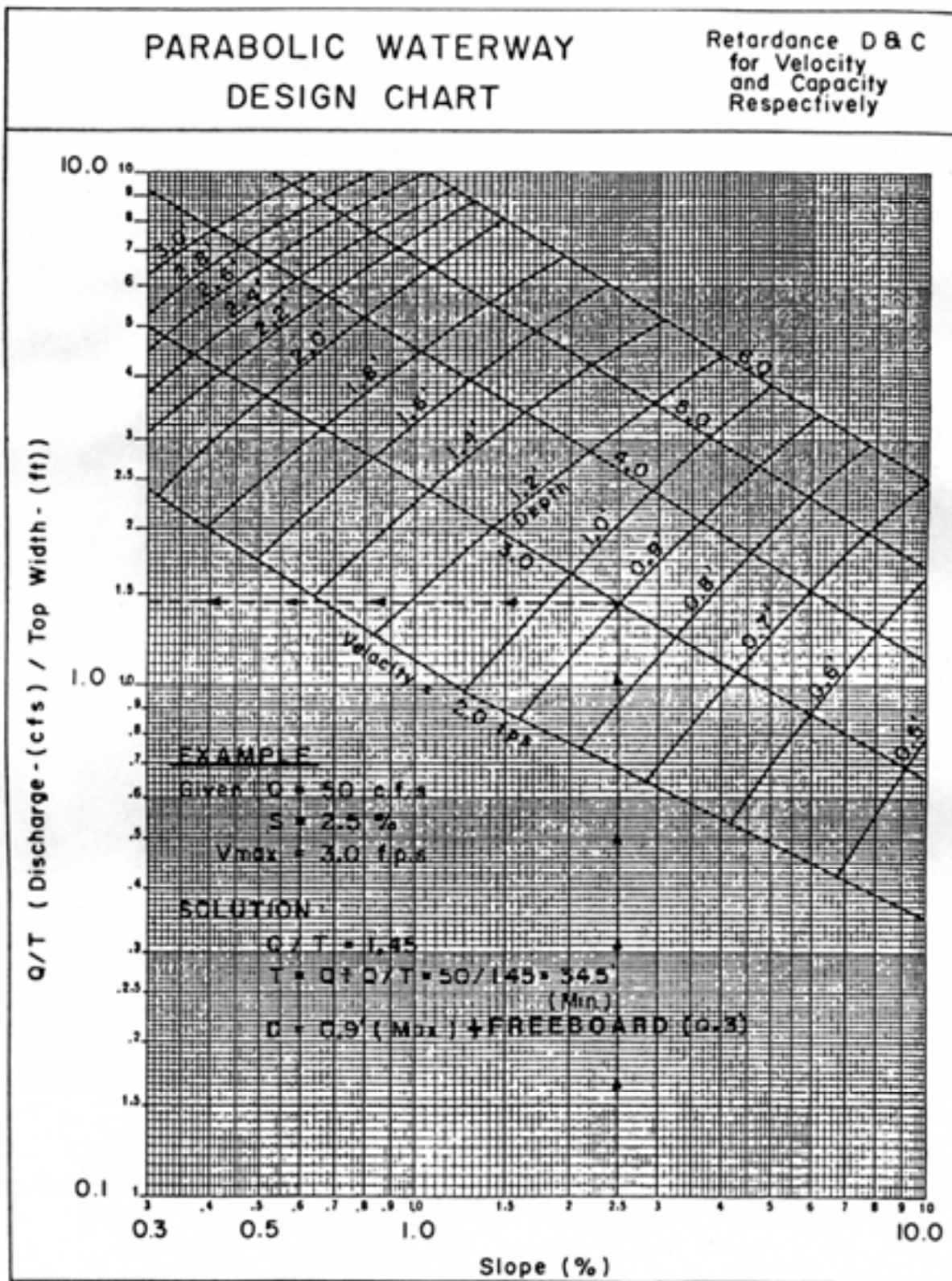

**Figure 3.10
Grassed Waterway Detail**

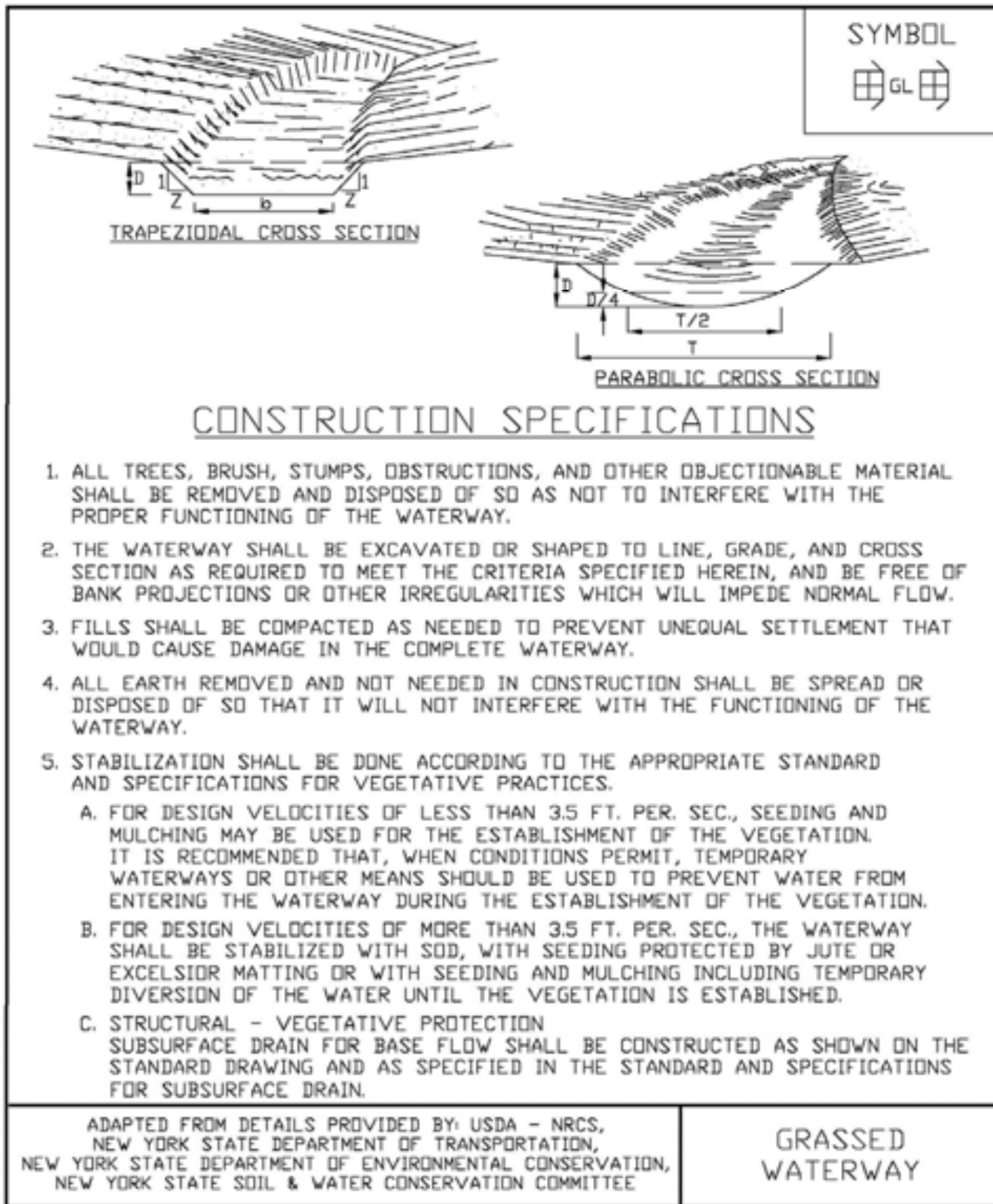

STANDARD AND SPECIFICATIONS FOR ROCK OUTLET PROTECTION



Definition & Scope

A **permanent** section of rock protection placed at the outlet end of the culverts, conduits, or channels to reduce the depth, velocity, and energy of water, such that the flow will not erode the receiving downstream reach.

Conditions Where Practice Applies

This practice applies where discharge velocities and energies at the outlets of culverts, conduits, or channels are sufficient to erode the next downstream reach. This applies to:

1. Culvert outlets of all types.
2. Pipe conduits from all sediment basins, dry storm water ponds, and permanent type ponds.
3. New channels constructed as outlets for culverts and conduits.

Design Criteria

The design of rock outlet protection depends entirely on the location. Pipe outlet at the top of cuts or on slopes steeper than 10 percent, cannot be protected by rock aprons or riprap sections due to re-concentration of flows and high velocities encountered after the flow leaves the apron.

Many counties and state agencies have regulations and design procedures already established for dimensions, type and size of materials, and locations where outlet protection is required. Where these requirements exist, they shall be followed.

Tailwater Depth

The depth of tailwater immediately below the pipe outlet

must be determined for the design capacity of the pipe. If the tailwater depth is less than half the diameter of the outlet pipe, and the receiving stream is wide enough to accept divergence of the flow, it shall be classified as a Minimum Tailwater Condition; see Figure 3.16 on page 3.42 as an example. If the tailwater depth is greater than half the pipe diameter and the receiving stream will continue to confine the flow, it shall be classified as a Maximum Tailwater Condition; see Figure 3.17 on page 3.43 as an example. Pipes which outlet onto flat areas with no defined channel may be assumed to have a Minimum Tailwater Condition; see Figure 3.16 on page 3.42 as an example.

Apron Size

The apron length and width shall be determined from the curves according to the tailwater conditions:

Minimum Tailwater – Use Figure 3.16 on page 3.42

Maximum Tailwater – Use Figure 3.17 on page 3.43

If the pipe discharges directly into a well defined channel, the apron shall extend across the channel bottom and up the channel banks to an elevation one foot above the maximum tailwater depth or to the top of the bank, whichever is less.

The upstream end of the apron, adjacent to the pipe, shall have a width two (2) times the diameter of the outlet pipe, or conform to pipe end section if used.

Bottom Grade

The outlet protection apron shall be constructed with no slope along its length. There shall be no overfall at the end of the apron. The elevation of the downstream end of the apron shall be equal to the elevation of the receiving channel or adjacent ground.

Alignment

The outlet protection apron shall be located so that there are no bends in the horizontal alignment.

Materials

The outlet protection may be done using rock riprap, grouted riprap, or gabions. Outlets constructed on the bank of a stream or wetland shall not use grouted rip-rap, gabions or concrete.

Riprap shall be composed of a well-graded mixture of rock size so that 50 percent of the pieces, by weight, shall be larger than the d_{50} size determined by using the charts. A

well-graded mixture, as used herein, is defined as a mixture composed primarily of larger rock sizes, but with a sufficient mixture of other sizes to fill the smaller voids between the rocks. The diameter of the largest rock size in such a mixture shall be 1.5 times the d_{50} size.

Thickness

The minimum thickness of the riprap layer shall be 1.5 times the maximum rock diameter for d_{50} of 15 inches or less; and 1.2 times the maximum rock size for d_{50} greater than 15 inches. The following chart lists some examples:

D_{50} (inches)	d_{max} (inches)	Minimum Blanket Thick- ness (inches)
4	6	9
6	9	14
9	14	20
12	18	27
15	22	32
18	27	32
21	32	38
24	36	43

Rock Quality

Rock for riprap shall consist of field rock or rough unhewn quarry rock. The rock shall be hard and angular and of a quality that will not disintegrate on exposure to water or weathering. The specific gravity of the individual rocks shall be at least 2.5.

Filter

A filter is a layer of material placed between the riprap and the underlying soil surface to prevent soil movement into and through the riprap. Riprap shall have a filter placed under it in all cases.

A filter can be of two general forms: a gravel layer or a plastic filter cloth. The plastic filter cloth can be woven or non-woven monofilament yarns, and shall meet these base requirements: thickness 20-60 mils, grab strength 90-120 lbs; and shall conform to ASTM D-1777 and ASTM D-1682.

Gravel filter blanket, when used, shall be designed by comparing particle sizes of the overlying material and the base material. Design criteria are available in Standard and Specification for Anchored Slope and Channel Stabilization on page 4.7.

Gabions

Gabions shall be made of hexagonal triple twist mesh with heavily galvanized steel wire. The maximum linear dimension of the mesh opening shall not exceed 4 ½ inches and the area of the mesh opening shall not exceed 10 square inches.

Gabions shall be fabricated in such a manner that the sides, ends, and lid can be assembled at the construction site into a rectangular basket of the specified sizes. Gabions shall be of single unit construction and shall be installed according to manufacturer's recommendations.

The area on which the gabion is to be installed shall be graded as shown on the drawings. Foundation conditions shall be the same as for placing rock riprap, and filter cloth shall be placed under all gabions. Where necessary, key, or tie, the structure into the bank to prevent undermining of the main gabion structure.

Maintenance

Once a riprap outlet has been installed, the maintenance needs are very low. It should be inspected after high flows for evidence of scour beneath the riprap or for dislodged rocks. Repairs should be made immediately.

Design Procedure

1. Investigate the downstream channel to assure that nonerosive velocities can be maintained.
2. Determine the tailwater condition at the outlet to establish which curve to use.
3. Use the appropriate chart with the design discharge to determine the riprap size and apron length required. It is noted that references to pipe diameters in the charts are based on full flow. For other than full pipe flow, the parameters of depth of flow and velocity must be used to adjust the design discharges.
4. Calculate apron width at the downstream end if a flare section is to be employed.

Design Examples are demonstrated in Appendix B.

Construction Specifications

1. The subgrade for the filter, riprap, or gabion shall be prepared to the required lines and grades. Any fill required in the subgrade shall be compacted to a density of approximately that of the surrounding undisturbed material.
2. The rock or gravel shall conform to the specified grad-

ing limits when installed respectively in the riprap or filter.

3. Filter cloth shall be protected from punching, cutting, or tearing. Any damage other than an occasional small hole shall be repaired by placing another piece of cloth over the damaged part or by completely replacing the cloth. All overlaps, whether for repairs or for joining two pieces of cloth shall be a minimum of one foot.
4. Rock for the riprap or gabion outlets may be placed by equipment. Both shall each be constructed to the full course thickness in one operation and in such a manner as to avoid displacement of underlying materials. The rock for riprap or gabion outlets shall be delivered and placed in a manner that will ensure that it is reasonably homogenous with the smaller rocks and spalls filling the voids between the larger rocks. Riprap shall be placed in a manner to prevent damage to the filter blanket or filter cloth. Hand placement will be required to the extent necessary to prevent damage to the permanent works.

Figure 3.16
Outlet Protection Design—Minimum Tailwater Condition Chart
(Design of Outlet Protection from a Round Pipe Flowing Full,
Minimum Tailwater Condition: $T_w < 0.5D_o$) (USDA - NRCS)

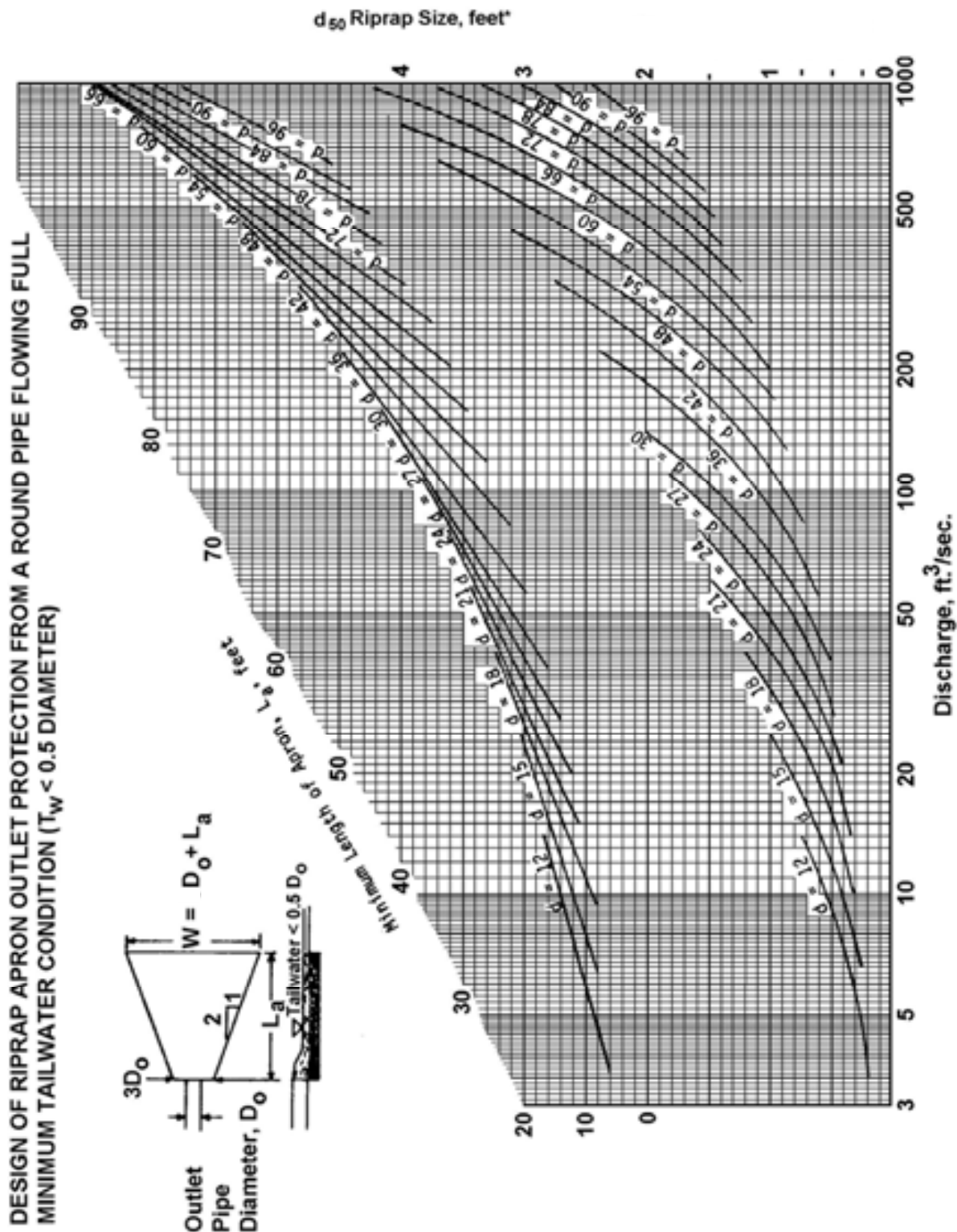

* For discharge velocities exceeding Maximum A for Riprap indicated, increase d₅₀ stone size and/or provide velocity reduction device.

Figure 3.17
Outlet Protection Design—Maximum Tailwater Condition Chart
(Design of Outlet Protection from a Round Pipe Flowing Full,
Maximum Tailwater Condition: $T_w \geq 0.5D_o$) (USDA - NRCS)

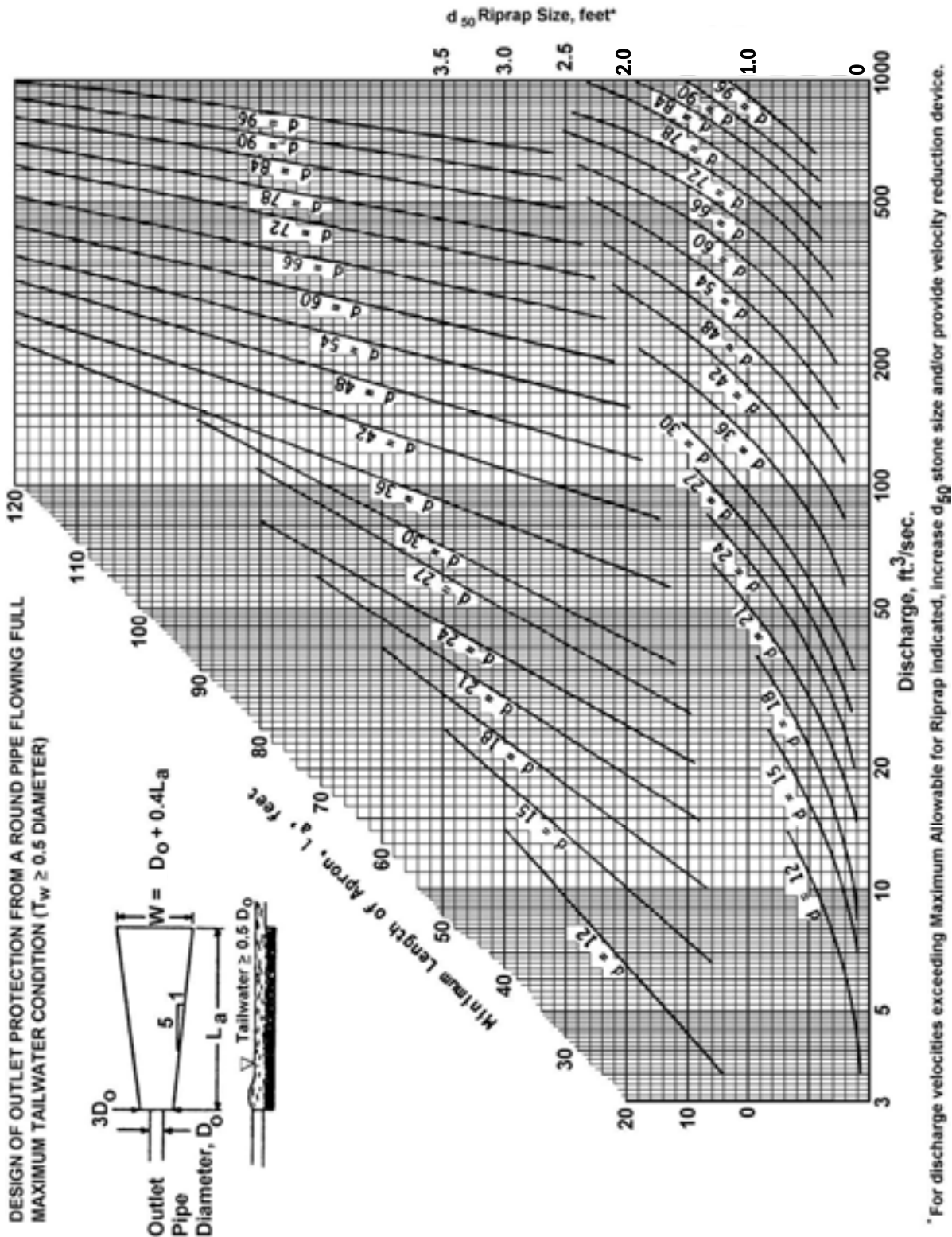

**Figure 3.18
Riprap Outlet Protection Detail (1)**

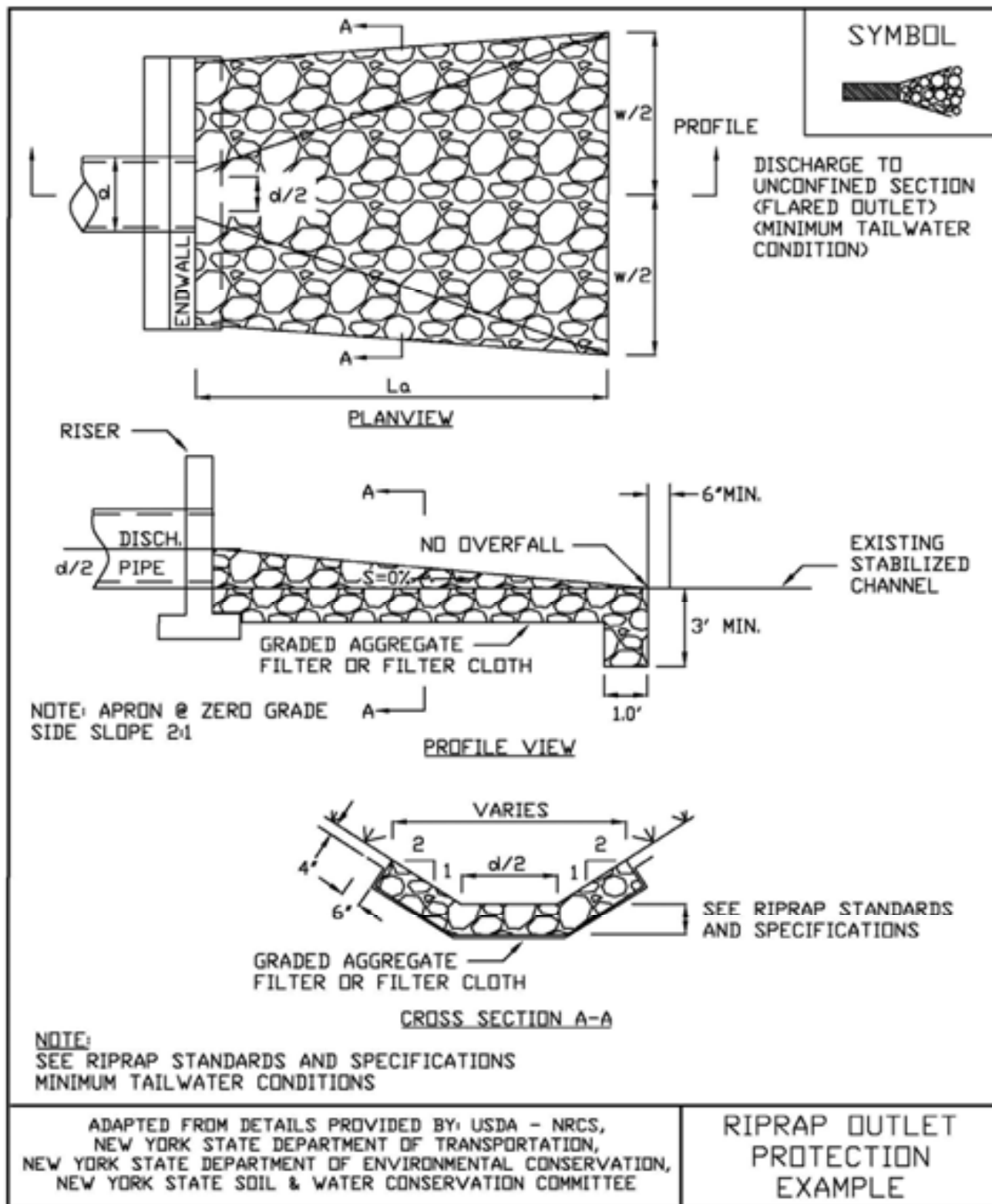

**Figure 3.19
Riprap Outlet Protection Detail (2)**

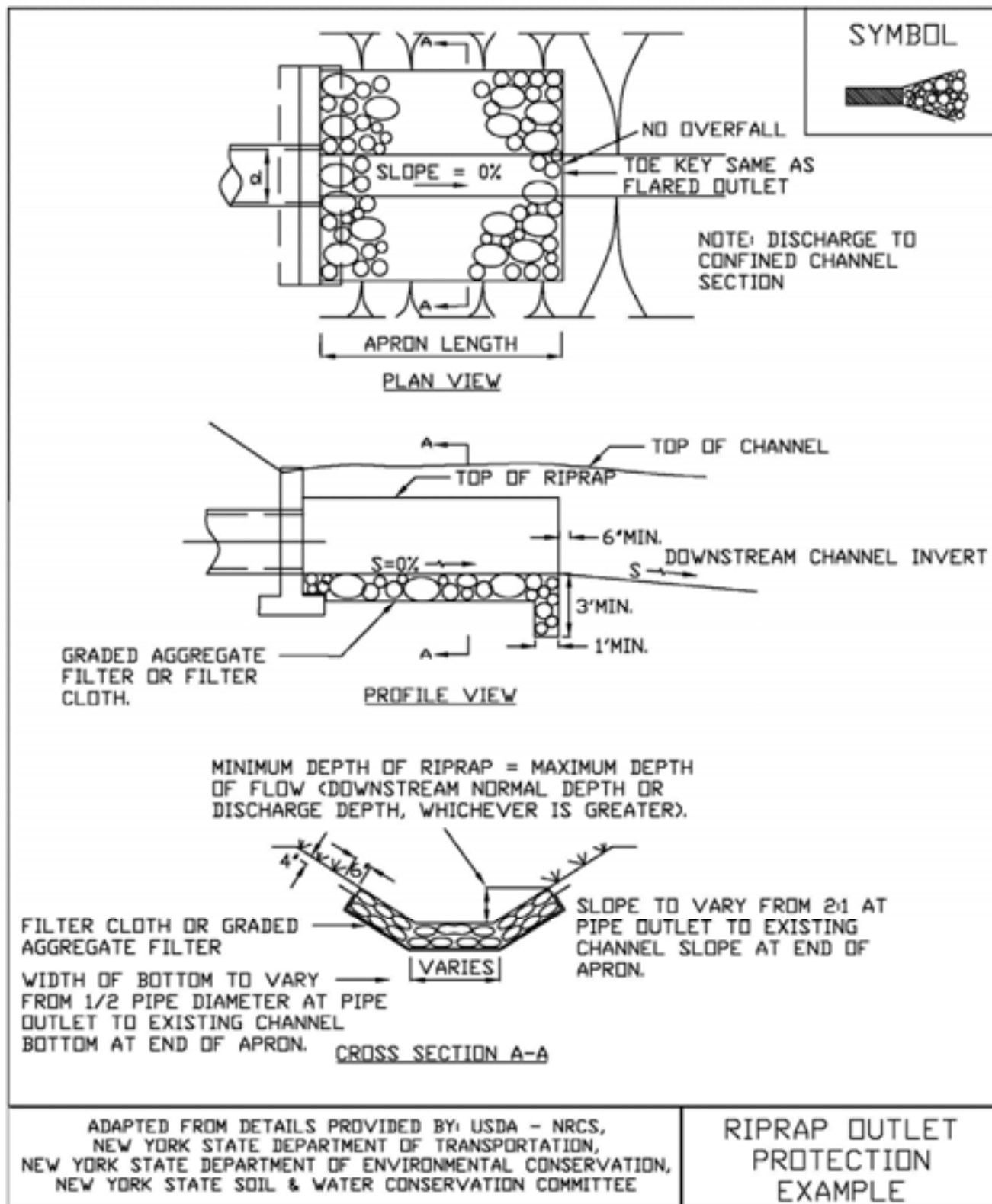

**Figure 3.20
Riprap Outlet Protection Detail (3)**

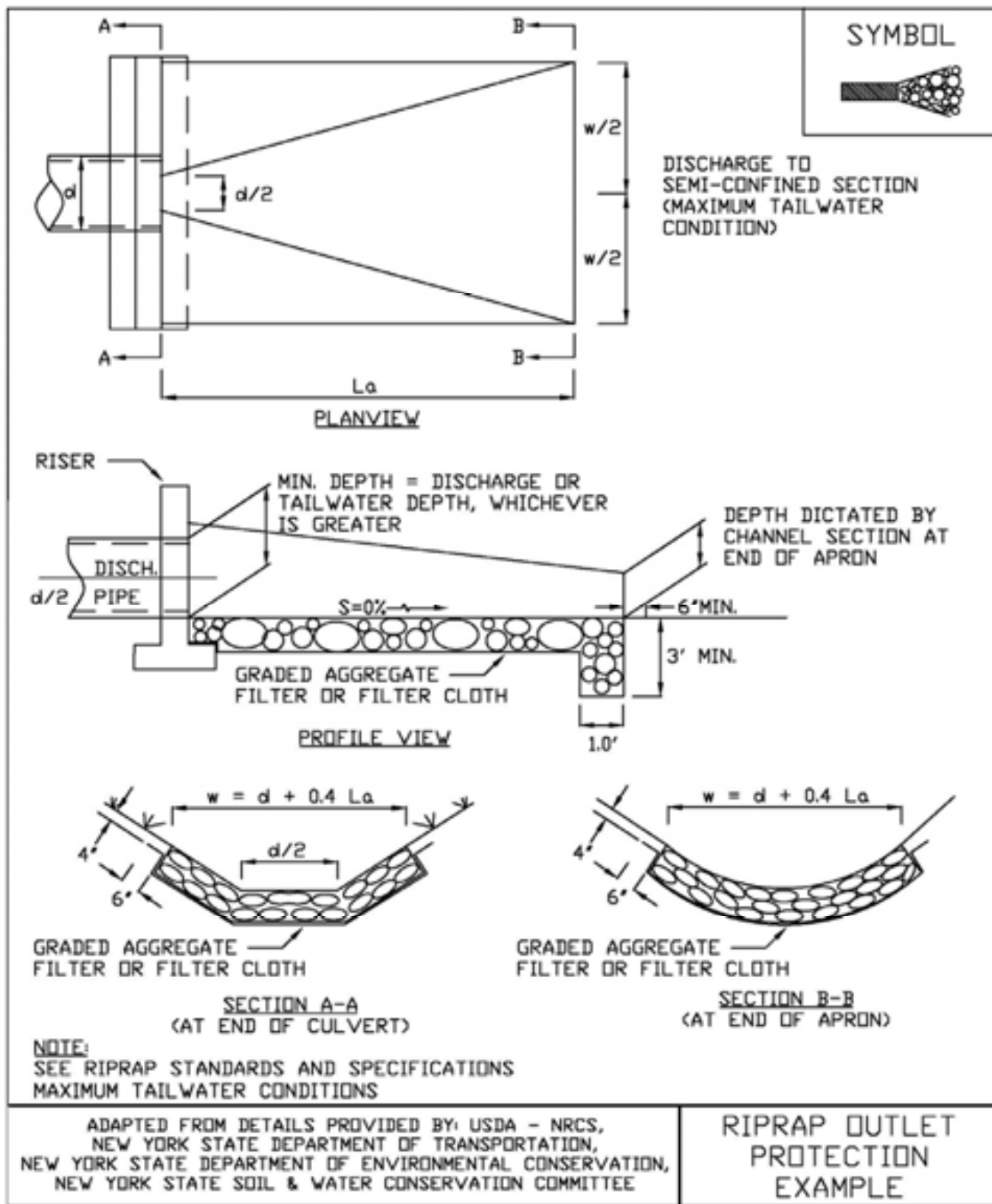

STANDARD AND SPECIFICATIONS FOR WATER BAR



Definition & Scope

A **permanent** or **temporary** ridge, ridge and channel, a structural channel, or flow deflector, constructed diagonally across a sloping road or utility right-of-way that is subject to erosion to limit the accumulation of erosive velocity of water by diverting surface runoff at pre-designed intervals.

Conditions Where Practice Applies

Where runoff protection is needed to prevent erosion from increased concentrated flow on narrow, steep access roads, driveways, and entrance ways to lot parcels as well as utility access right-of-ways generally up to 100 feet in width

Design Criteria

Design computations are not required.

1. The design height shall be minimum of 12 inches measured from channel bottom to ridge top.
2. The side slopes shall be 2:1 or flatter, a minimum of 4:1 where vehicles cross.
3. The base width of the ridge shall be six feet minimum.
4. The spacing of the water bars shall be as follows (Site spacing may need to be adjusted for field conditions to use the most suitable areas for water disposal):

Slope (%)	Spacing (ft.)
<5	125
5 TO 10	100
10 TO 20	75
20 TO 35	50
>35	25

5. The positive grade of the water bar shall not exceed 2%. A crossing angle of approximately 60 degrees is preferred.
6. Once diverted, water must be conveyed to a stable system (i.e. vegetated swale or storm sewer system). Water bars should have stable, unrestricted outlets, either natural or constructed.

See Figure 3.22 on page 3.53 for details.



**Figure 3.22
Water Bar Detail**

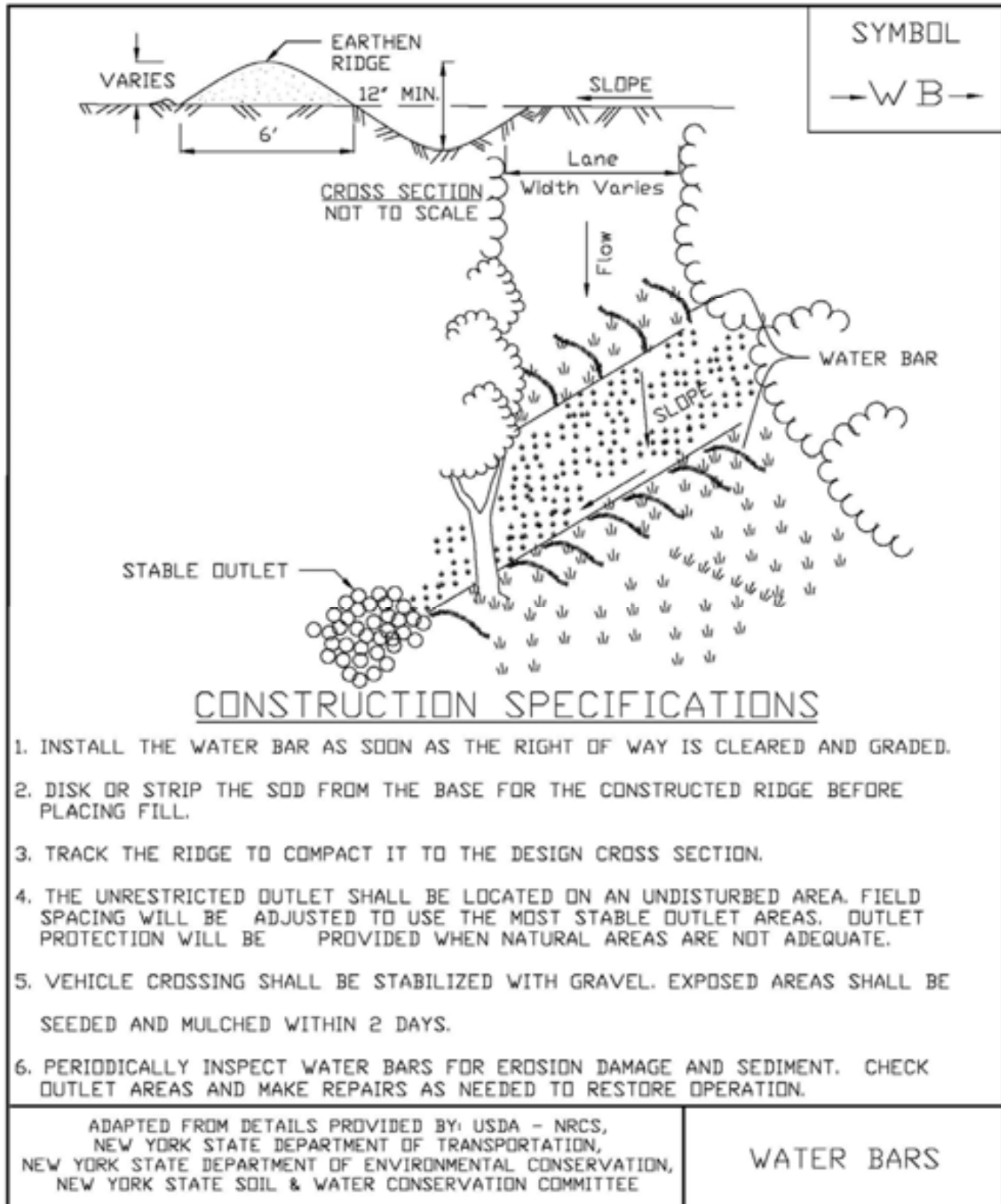

STANDARD AND SPECIFICATIONS FOR ANCHORED STABILIZATION MATTING



Definition and Scope

A **temporary** or **permanent** protective covering placed on a prepared, seeded planting area that is anchored in place by staples or other means to aid in controlling erosion by absorbing rain splash energy and withstand overland flow as well as provide a microclimate to protect and promote seed establishment.

Conditions Where Practice Applies

Anchored stabilization mats are required for seeded earthen slopes steeper than 3 horizontal to 1 vertical; in vegetated channels where the velocity of the design flow exceeds the allowable velocity for vegetation alone (usually greater than 5 feet per second); on streambanks and shorelines where moving water is likely to erode newly seeded or planted areas; and in areas where wind prevents standard mulching with straw. This standard does not apply to slopes stabilized with sod, rock riprap or hard armor material.

Design Criteria

Slope Applications - Anchored stabilization mats for use on slopes are primarily used as mulch blankets where the mesh material is within the blanket or as a netting over previously placed mulch. These stabilization mats are NOT effective in preventing slope failures.

1. Required on all slopes steeper than 3:1
2. Matting will be designed for proper longevity need and strength based on intended use.
3. All installation details and directions will be included on the site erosion and sediment control plan and will follow manufactures specifications.

Channel Applications - Anchored stabilization mats, for use in supporting vegetation in flow channels, are generally a non-degradable, three dimensional plastic structure which can be filled with soil prior to planting. This structure provides a medium for root growth where the matting and roots become intertwined forming a continuous anchor for the vegetated lining.

1. Channel stabilization shall be based on the tractive force method.
2. For maximum design shear stresses less than 2 pounds per square foot, a temporary or bio-degradable mat may be used.
3. The design of the final matting shall be based on the mats ability to resist the tractive shear stress at bank full flow.
4. The installation details and procedures shall be included on the site erosion and sediment control plan and will follow manufacturers specifications.



Construction Specifications

1. Prepare soil before installing matting by smoothing the surface, removing debris and large stone, and applying lime, fertilizer and seed. Refer to manufacturers installation details.
2. Begin at the top of the slope by anchoring the mat in a 6" deep x 6" wide trench. Backfill and compact the trench after stapling.
3. In channels or swales, begin at the downslope end, anchoring the mat at the bottom and top ends of the blanket. When another roll is needed, the upslope roll

should overlay the lower layer, shingle style, so that channel flows do not peel back the material.

4. Roll the mats down a slope with a minimum 4" overlap. Roll center mat in a channel in direction of water flow on bottom of the channel. Do not stretch blankets. Blankets shall have good continuous contact with the underlying soil throughout its entire length.
5. Place mats end over end (shingle style) with a 6" overlap, use a double row of staggered staples 4" apart to secure mats.
6. Full length edge of mats at top of side slopes must be anchored in 6" deep x 6" wide trench; backfill and compact the trench after stapling.
7. Mats on side slopes of a channel must be overlapped 4" over the center mat and stapled.
8. In high flow channel applications, a staple check slot is recommended at 30 to 40 foot intervals. Use a row of staples 4" apart over entire width of the channel. Place a second row 4" below the first row in a staggered pattern.
9. The terminal end of the mats must be anchored in a 6"x6" wide trench. Backfill and compact the trench after stapling.
10. Stapling and anchoring of blanket shall be done in accordance with the manufactures recommendations.

Maintenance

Blanketed areas shall be inspected weekly and after each runoff event until perennial vegetation is established to a minimum uniform 80% coverage throughout the blanketed area. Damaged or displaced blankets shall be restored or replaced within 2 calendar days.

STANDARD AND SPECIFICATIONS FOR ARMORED SLOPE AND CHANNEL STABILIZATION



Definition & Scope

A **permanent** layer of stone designed to protect and stabilize areas subject to erosion by protecting the soil surface from rain splash, sheet flow, rill and gully erosion and channel erosion. It can also be used to improve the stability of soil slopes that are subject to seepage or have poor soil structure.

Conditions Where Practice Applies

Riprap is used for cut and fill slopes subject to seepage, erosion, or weathering, particularly where conditions prohibit the establishment of vegetation. Riprap is also used for channel side slopes and bottoms, temporary dewatering diversion channels where the flow velocities exceed 6 feet/second, grade sills, on shorelines subject to erosion, and at inlets and outlets to culverts, bridges, slope drains, grade stabilization structures, and storm drains.

Slope Stabilization Design Criteria

Gradation – Riprap shall be a well-graded mixture with 50% by weight larger than the specified design size. The diameter of the largest stone size in such a mixture should be 1.5 times the d_{50} size with smaller sizes grading down to 1 inch. The designer should select the size or sizes that equal or exceed that minimum size based on riprap gradations commercially available in the area.

Thickness – The minimum layer thickness shall be 1.5 times the maximum stone diameter, but in no case less than 6 inches.

Quality – Stone for riprap shall be hard, durable field or quarry materials. They shall be angular and not subject to breaking down when exposed to water or weathering. The specific gravity shall be at least 2.5.

Size – The sizes of stones used for riprap protection are determined by purpose and specific site conditions:

1. Slope Stabilization – Riprap stone for slope stabilization not subject to flowing water or wave action shall be sized for the proposed grade. The gradient of the slope to be stabilized shall be less than the natural angle of repose of the stone selected. Angles of repose of riprap stones may be estimated from Figure 4.1.

Riprap used for surface stabilization of slopes does not add significant resistance to sliding or slope failure and should not be considered a retaining wall. Slopes approaching 1.5:1 may require special stability analysis. The inherent stability of the soil must be satisfactory before riprap is used for surface stabilization.

2. Channel Stabilization - Design criteria for sizing stone for stability of channel side slopes are presented under Channel Stabilization Design Criteria on page 4.10.
2. Outlet Protection – Design criteria for sizing stone and determining dimensions of riprap aprons are presented in Standards and Specifications for Rock Outlet Protection on page 3.39.

Filter Blanket – A filter blanket is a layer of material placed between the riprap and the underlying soil to prevent soil movement into or through the riprap. A suitable filter may consist of a well-graded gravel or sand-gravel layer or a synthetic filter fabric manufactured for this purpose. The design of a gravel filter blanket is based on the ratio of particle size in the overlying filter material to that of the base material in accordance with the criteria below. Multiple layers may be designed to affect a proper filter if necessary.

A gravel filter blanket should have the following relationship for a stable design:

$$\frac{d_{15} \text{ filter}}{d_{25} \text{ base}} \leq 5$$

$$5 < \frac{d_{15} \text{ filter}}{d_{50} \text{ base}} \leq 40$$

and

$$\frac{d_{20} \text{ filter}}{d_{20} \text{ base}} \leq 40$$

Filter refers to the overlying material while base refers to the underlying material. These relationships must hold between the base and filter and the filter and riprap to prevent migration of material. In some cases, more than one filter may be needed. Each filter layer should be a minimum of 6 inches thick, unless an acceptable filter fabric is used.

A synthetic filter fabric may be used with or in place of gravel filters. The following particle size relationships should exist:

1. Filter fabric covering a base containing 50% or less by weight of fine particles (#200 sieve size):

A.
$$\frac{d_{85} \text{ base (mm)}}{\text{EOS} \times \text{filter fabric (mm)}} > 1$$

- B. total open area of filter fabric should not exceed 36%

2. Filter fabric covering other soils:

- A. EOS is no larger than 0.21 mm (#70 sieve size)

- B. total open area of filter fabric should not exceed 10%

*EOS – Equivalent opening size compared to a U.S. standard sieve size.

No filter fabric should have less than 4% open area or an EOS less than U.S. Standard Sieve #100 (0.15 mm). The permeability of the fabric must be greater than that of the soil. The fabric may be made of woven or nonwoven monofilament yarns and should meet the following minimum requirements:

Thickness 20-60 mils

grab strength 90-120 lbs.

conform to ASTM D-1682 or ASTM D-177

Filter blankets should always be provided where seepage is significant or where flow velocity and duration of flow or turbulence may cause underlying soil particles to move through the riprap.

Construction Specifications

Subgrade Preparation – Prepare the subgrade for riprap and filter to the required lines and grades shown on the plans. Compact any fill required in the subgrade to a density approximating that of the undisturbed material or overfill depressions with riprap. Remove brush, trees, stumps, and other objectionable material. Cut the subgrade sufficiently deep so that the finished grade of the riprap will be at the

elevation of the surrounding area. Channels shall be excavated sufficiently to allow placement of the riprap in a manner such that the finished inside dimensions and grade of the riprap meet design specifications.

Sand and gravel filter blanket – Place the filter blanket immediately after the ground foundation is prepared. For gravel, spread filter stone in a uniform layer to the specified depth. Where more than one layer of filter material is used, spread the layers with minimal mixing.

Synthetic filter fabric – Place the cloth directly on the prepared foundation. Overlap the edges by at least 2 feet, and space the anchor pins every 3 feet along the overlap. Bury the upper and lower ends of the cloth a minimum of 12 inches below ground. Take precautions not to damage the cloth by dropping the riprap. If damage occurs, remove the riprap and repair the sheet by adding another layer of filter fabric with a minimum overlap of 12 inches around the damaged area. Where large stones are to be placed, a 4-inch layer of fine sand or gravel is recommended to protect the filter cloth. Filter fabric is not recommended as a filter on slopes steeper than 2 horizontal to 1 vertical.

Stone placement – Placement of the riprap shall follow immediately after placement of the filter. Place riprap so that it forms dense, well-graded mass of stone with a minimum of voids. The desired distribution of stones throughout the mass may be obtained by selective loading at the quarry and controlled dumping during final placement. Place riprap to its full thickness in one operation. Do not place riprap by dumping through chutes or other methods that cause segregation of stone sizes. Be careful not to dislodge the underlying base or filter when placing the stones.

The toe of the riprap shall be keyed into a stable foundation at its base as shown in Figure 4.2 - Typical Riprap Slope Protection Detail. The toe should be excavated to a depth of 2.0 feet. The design thickness of the riprap shall extend a minimum of 3 feet horizontally from the slope. The finished slope should be free of pockets of small stone or clusters of large stones. Hand placing may be necessary to achieve proper distribution of stone sizes to produce a relatively smooth, uniform surface. The finished grade of the riprap should blend with the surrounding area.

Maintenance

Riprap shall be inspected periodically for scour or dislodged stones. Control weed and brush growth as needed.

Figure 4.1
Angles of Repose of Riprap Stones (FHWA)

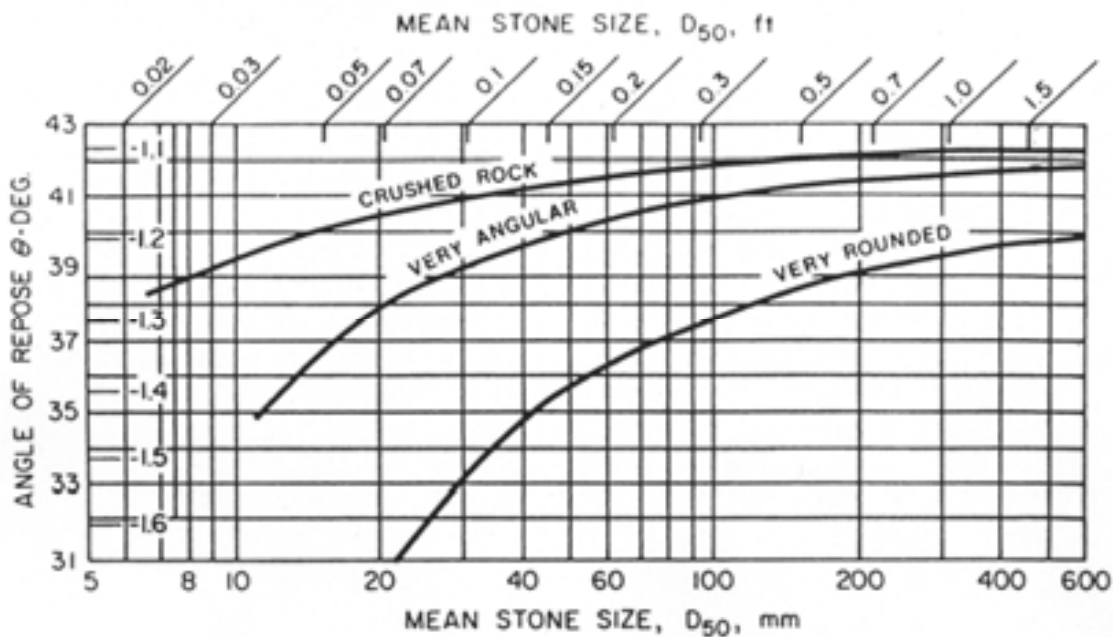
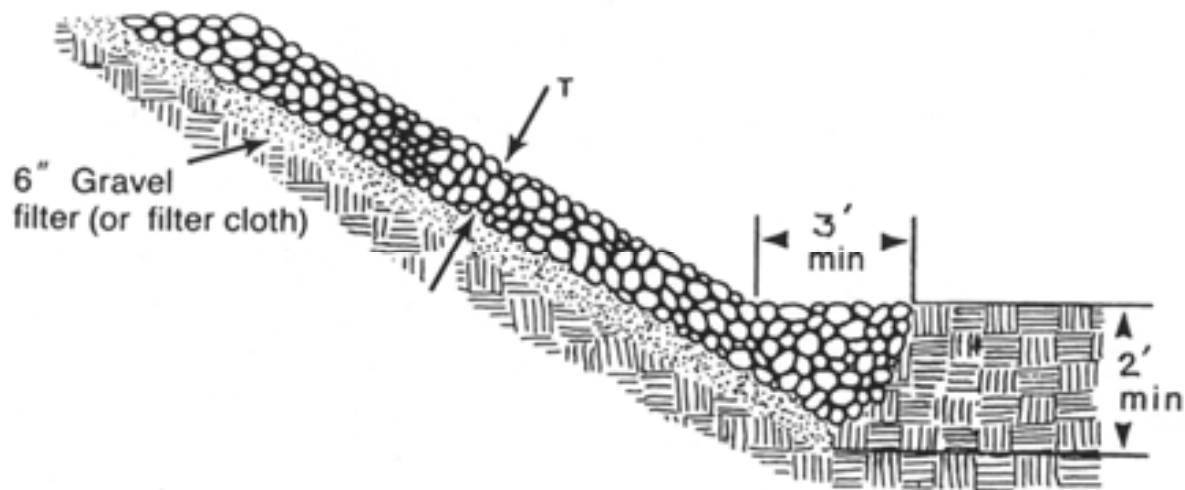

Figure 4.2
Typical Riprap Slope Protection Detail





Channel Stabilization Design Criteria

1. Since each channel is unique, measures for structural channel stabilization should be installed according to a design based on specific site conditions.
2. The plan and profile of the design reach should approximate a naturally stable channel from the project area, based on a stable “reference reach” for the subject channel type.
3. Develop designs according to the following principles:
 - Make protective measures compatible with other channel modifications planned or being carried out in the channel reaches.
 - Whenever excavation and re-shaping work is proposed within channels, the design should provide functional channel dimensions and geometry at each section. Work proposed within a stream channel may require permits from the NYS DEC and US Army Corps of Engineers.
 - Use the design velocity of the peak discharge of the 10-year storm or bankfull discharge, whichever is less. Structural measures should be capable of withstanding greater flows without serious damage.
 - Ensure that the channel bottom is stable or stabilized by structural means before installing any permanent slope protection.
 - Channel stabilization should begin at a stable location and end at a stable point along the bank.
 - Changes in alignment should not be done without a complete analysis of the environmental and stability effects on the entire system.
 - Provisions should be made to maintain and improve fish and wildlife habitat. For example, restoring lost vegetation will provide valuable shade, food, and/or cover.
 - Ensure that all requirements of state law and all permit requirements of local, state, and federal agencies are met.

Construction Specifications

Riprap – Riprap is the most commonly used material to structurally stabilize a channel. While riprap will provide the structural stabilization necessary, the side slope can be enhanced with vegetative material to slow the velocity of water, filter debris, and enhance habitat. See [Principles of Biotechnical Practices](#) on page 4.1, for more information.

1. Side slope – slopes shall be graded to 2:1 or flatter prior to placing bedding, filter fabric, or riprap.
2. Filter – filters should be placed between the base material and the riprap and meet the requirements of criteria listed pages 4.7 and 4.8.
3. Gradation – The gradation of the riprap is dependent on the velocity expected against the bank for the design conditions. See Table 4.1 on page 4.12. Once the velocity is known, gradation can be selected from the table for the appropriate class of rock. Note, this table was developed for a 2:1 slope; if the slope steepens to 1.5:1 the gradations should be increased 20%. The riprap should extend 2 feet below the channel bottom and be keyed into the side slope both at the upstream end and downstream end of the proposed work or reach.

See Figure 4.3 on page 4.13 for details.

Reinforced Concrete - Is often used to armor eroding sections of flow channel by constructing walls, bulk heads, or stabilize bank linings in urban areas for redevelopment work. Provide positive drainage behind these structures to relieve uplift pressures.



Grid Pavers – Modular concrete units with or without void areas can be used to stabilize flow channel. Units with void areas can allow the establishment of vegetation. These structures may be obtained in a variety of shapes (Figure 4.4) or they may be formed and poured in place. Maintain design and installation in accordance with manufacturer’s instructions.



Revetment – Structural support or armoring to protect an embankment from erosion. Riprap and gabions are commonly used. Also used is a hollow fabric mattress with cells that receive a concrete mixture. Any revetment should be installed to a depth below the anticipated channel degradation and into the channel bed as necessary to provide stability.



Modular Pre-Cast Units – Interlocking modular precast units of different sizes, shapes, heights, and depths, have been developed for a wide variety of applications. They provide vertical support in tight areas as well as durability. Many types are available with textured surfaces. They also act as gravity retaining walls. They should be designed and installed in accordance with the manufacturer’s recommendations (Figure 4.4). All areas disturbed by construction should be stabilized as soon as the structural measures are complete.



Maintenance

Check stabilized flow channel sections after every high-water event, and make any needed repairs immediately to prevent any further damage or unraveling of the existing work.

Table 4.1 - Riprap Gradations for Channel Stabilization

Class	Layer Thickness (in.)	Max. Velocity (ft/s)	Wave Height (ft.)	PERCENT FINER BY WEIGHT											
				D ₁₀			D ₅₀			D ₈₅			D ₁₀₀		
				Wt. (lbs.)	d _o (in.)	d _□ (in.)	Wt. (lbs.)	d _o (in.)	d _□ (in.)	Wt. (lbs.)	d _o (in.)	d _□ (in.)	Wt. (lbs.)	d _o (in.)	d _□ (in.)
I	18	8.5	-	5	5	4	50	10	8	100	13	10	150	15	12
II	18	10	-	17	7	6	170	15	12	340	19	15	500	22	18
III	24	12	2	46	10	8	460	21	17	920	26	21	1400	30	24
IV	36	14	3	150	15	12	1500	30	25	3000	39	32	4500	47	36
V	48	17	4.8	370	20	16	3700	42	34	7400	53	43	11,000	60	49

d_o = gravel material d_□ = angular rock riprap
 Wt = weight in pounds

**Figure 4.3
Riprap Channel Stabilization**

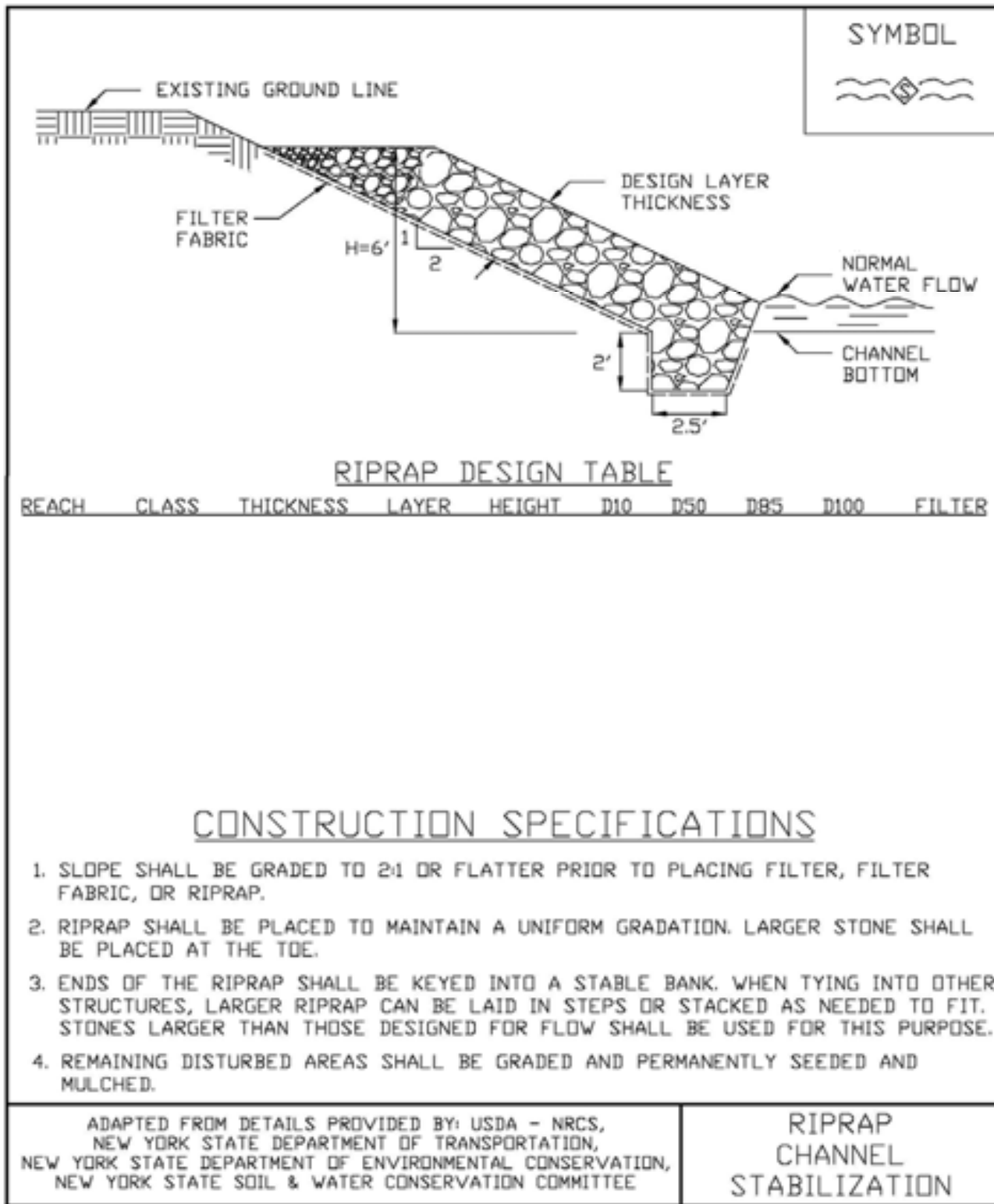

**Figure 4.4
Channel Stabilization Methods**

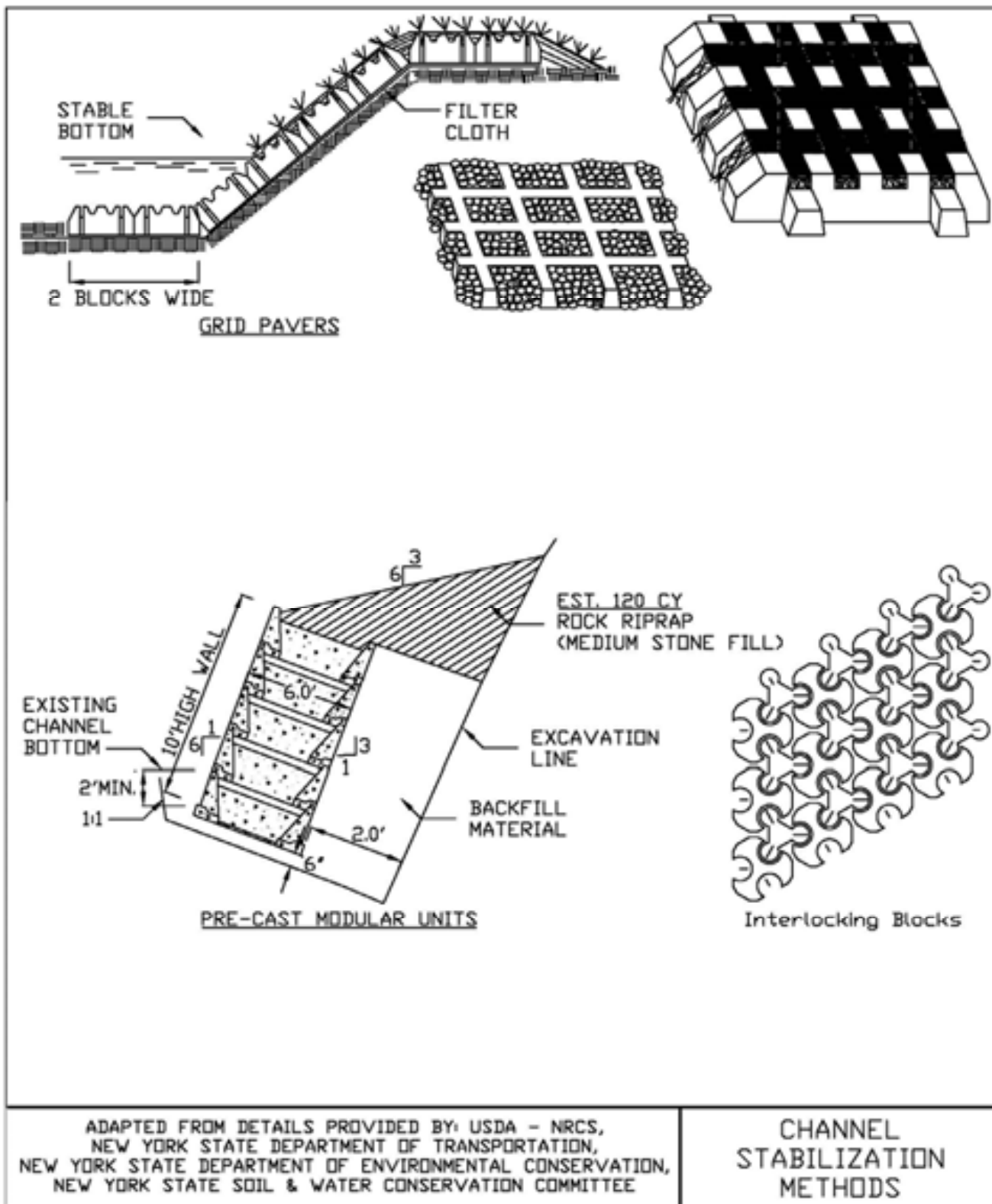

STANDARD AND SPECIFICATIONS FOR FERTILIZER APPLICATION



Definition & Scope

The **permanent** incorporation of fertilizer into the planting zone of the soil profile to provide nutrient amendments to the soil for vigorous support to plant and vegetation growth.

Conditions Where Practice Applies

This standard applies to all areas where permanent seeding, sodding, and plant establishment is required. All application of fertilizer shall be in accordance with Nutrient Runoff Law - ECL Article 17, Title 21. Phosphorus runoff poses a threat to water quality. Therefore, under New York Law, fertilizer containing phosphorus may only be applied to lawn or non-agricultural turf when:

1. A soil test indicates that additional phosphorus is needed for growth of that lawn or non-agricultural turf, or
2. The fertilizer is used for newly established lawn or non-agricultural turf during the first growing season.

For projects located within watersheds where enhanced phosphorus removal standards are required as part of its post-construction stormwater management plan, use of any fertilizer containing more than 0.67 percent phosphate (P_2O_5) content will be done only with a valid soil test demonstrating the need for that formulation.

Design Criteria

Fertilizer is sold with an analysis printed on the tag or bag shown as three numbers separated by a dash, such as 5-10-5. The first number is the percent of the total weight of the bag that is nitrogen (N), the second is the percent of

phosphate (phosphorus, P), and the third is the percent of potash (potassium, K). Other elements are sometimes included and are listed with these three basic components.

For example a 40 lb bag of 5-10-5 fertilizer contains 5% of 40 lbs of Nitrogen which equals 2 lbs. There is 10% of 40 lbs of phosphate (phosphorus) which equals 4 lbs, and there is 5% of potash (potassium), another 2 lbs., for a total of 8 lbs of active fertilizer in the 40 lb bag. The rest is filler to aid in spreading the material over the area to be treated.

Specify the design fertilizer mix and application rates based on the results of the soil tests.

Specifications

1. In no case shall fertilizer be applied between December 1 and April 1 annually.
2. Fertilizer shall not be spread within 20 feet of a surface water.
3. Any fertilizer falling or spilled into impervious surface areas such as parking lots, roadways, and sidewalks should be immediately contained and legally applied or placed in an appropriate container.
4. Incorporate the fertilizer, and lime if specified, into the top 2-4 inches of the topsoil or soil profile.
5. When applying fertilizer by hydro seeding care should be taken to apply mix only to seed bed areas at an appropriate flow rate to prevent erosion and spraying onto impervious areas.



STANDARD AND SPECIFICATIONS FOR FIBER ROLL



Definition & Scope

A fiber roll is a coir (coconut fiber), straw, or excelsior roll encased in netting of jute, nylon, or burlap to dissipate energy along streambanks, channels, and bodies of water and to reduce sheet flow on slopes.

Conditions Where Practice Applies

Fiber rolls are used where the water surface levels are relatively constant. Artificially controlled streams for hydropower are not good candidates for this technique. The rolls provide a good medium for the introduction of herbaceous vegetation. Planting in the fiber roll is appropriate where the roll will remain continuously wet.

Design Criteria

1. The roll is placed in a shallow trench dug below baseflow or in a 4 inch trench on the slope contour and anchored by 2" x 2", 3-foot long posts driven on each side of the roll (see Figure 4.8).
2. The roll is contained by a 9-gauge non-galvanized wire placed over the roll from post to post. Braided nylon rope (1/8" thick) may be used.
3. The anchor posts shall be spaced laterally 4 feet on center on both sides of the roll and driven down to the top of the roll.
4. Soil is placed behind the roll and planted with suitable herbaceous or woody vegetation. If the roll will be continuously saturated, wetland plants may be planted into voids created in the upper surface of the roll.
5. Where water levels may fall below the bottom edge of the roll, a brush layer of willow should be installed so

as to lay across the top edge of the roll.

6. Where fiber rolls are used to reduce sheet flow on slopes they should be at least 12" in diameter and spaced according to the straw bale dike standard for sediment control.

Maintenance

Due to the susceptibility of plant materials to the physical constraints of the site, climate conditions, and animal populations, it is necessary to inspect installations frequently. This is especially important during the first year or two of establishment. Plant materials missing or damaged should be replaced as soon as possible. Sloughs or breaks in drainage pattern should be reestablished for the site as quickly as possible to maintain stability.



**Figure 4.8
Fiber Roll**

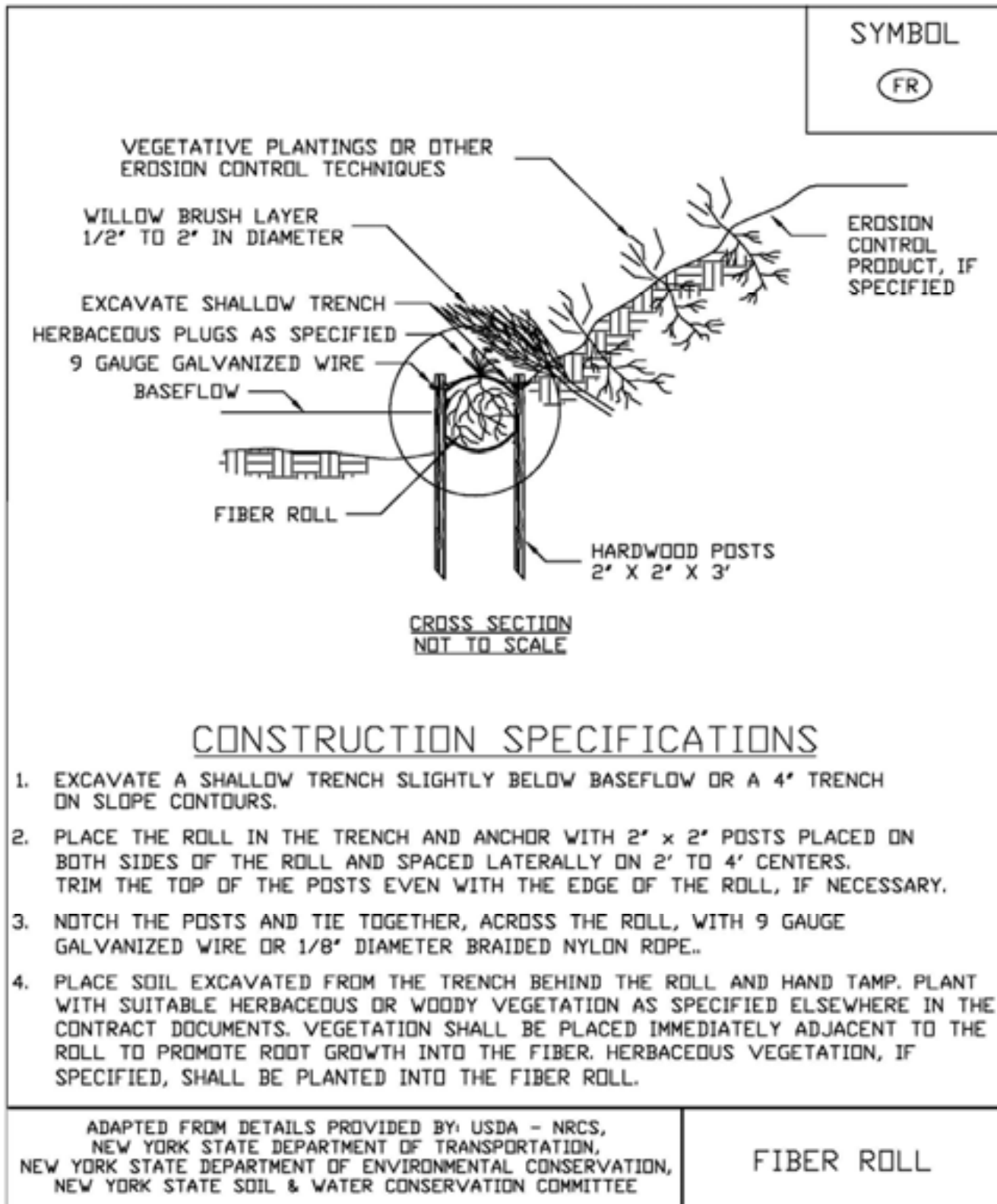

STANDARD AND SPECIFICATIONS FOR LANDGRADING



Definition & Scope

Permanent reshaping of the existing land surface by grading in accordance with an engineering topographic plan and specification to provide for erosion control and vegetative establishment on disturbed, reshaped areas.

Design Criteria

The grading plan should be based upon the incorporation of building designs and street layouts that fit and utilize existing topography and desirable natural surrounding to avoid extreme grade modifications. Information submitted must provide sufficient topographic surveys and soil investigations to determine limitations that must be imposed on the grading operation related to slope stability, effect on adjacent properties and drainage patterns, measures for drainage and water removal, and vegetative treatment, etc.

Many municipalities and counties have regulations and design procedures already established for land grading and cut and fill slopes. Where these requirements exist, they shall be followed.

The plan must show existing and proposed contours of the area(s) to be graded. The plan shall also include practices for erosion control, slope stabilization, safe disposal of runoff water and drainage, such as waterways, lined ditches, reverse slope benches (include grade and cross section), grade stabilization structures, retaining walls, and surface and subsurface drains. The plan shall also include phasing of these practices. The following shall be incorporated into the plan:

1. Provisions shall be made to safely convey surface runoff to storm drains, protected outlets, or to stable water courses to ensure that surface runoff will not

damage slopes or other graded areas; see standards and specifications for Grassed Waterway, Diversion, or Grade Stabilization Structure.

2. Cut and fill slopes that are to be stabilized with grasses shall not be steeper than 2:1. When slopes exceed 2:1, special design and stabilization consideration are required and shall be adequately shown on the plans. (Note: Where the slope is to be mowed, the slope should be no steeper than 3:1, although 4:1 is preferred because of safety factors related to mowing steep slopes.)
3. Reverse slope benches or diversion shall be provided whenever the vertical interval (height) of any 2:1 slope exceeds 20 feet; for 3:1 slope it shall be increased to 30 feet and for 4:1 to 40 feet. Benches shall be located to divide the slope face as equally as possible and shall convey the water to a stable outlet. Soils, seeps, rock outcrops, etc., shall also be taken into consideration when designing benches.
 - A. Benches shall be a minimum of six feet wide to provide for ease of maintenance.
 - B. Benches shall be designed with a reverse slope of 6:1 or flatter to the toe of the upper slope and with a minimum of one foot in depth. Bench gradient to the outlet shall be between 2 percent and 3 percent, unless accompanied by appropriate design and computations.
 - C. The flow length within a bench shall not exceed 800 feet unless accompanied by appropriate design and computations; see Standard and Specifications for Diversion on page 3.9
4. Surface water shall be diverted from the face of all cut and/or fill slopes by the use of diversions, ditches and swales or conveyed downslope by the use of a designed structure, except where:
 - A. The face of the slope is or shall be stabilized and the face of all graded slopes shall be protected from surface runoff until they are stabilized.
 - B. The face of the slope shall not be subject to any concentrated flows of surface water such as from natural drainage ways, graded ditches, downspouts, etc.
 - C. The face of the slope will be protected by anchored stabilization matting, sod, gravel, riprap, or other stabilization method.

5. Cut slopes occurring in ripable rock shall be serrated as shown in Figure 4.9 on page 4.26. The serrations shall be made with conventional equipment as the excavation is made. Each step or serration shall be constructed on the contour and will have steps cut at nominal two-foot intervals with nominal three-foot horizontal shelves. These steps will vary depending on the slope ratio or the cut slope. The nominal slope line is 1 ½: 1. These steps will weather and act to hold moisture, lime, fertilizer, and seed thus producing a much quicker and longer-lived vegetative cover and better slope stabilization. Overland flow shall be diverted from the top of all serrated cut slopes and carried to a suitable outlet.
6. Subsurface drainage shall be provided where necessary to intercept seepage that would otherwise adversely affect slope stability or create excessively wet site conditions.
7. Slopes shall not be created so close to property lines as to endanger adjoining properties without adequately protecting such properties against sedimentation, erosion, slippage, settlement, subsidence, or other related damages.
8. Fill material shall be free of brush, rubbish, rocks, logs, stumps, building debris, and other objectionable material. It should be free of stones over two (2) inches in diameter where compacted by hand or mechanical tampers or over eight (8) inches in diameter where compacted by rollers or other equipment. Frozen material shall not be placed in the fill nor shall the fill material be placed on a frozen foundation.
9. Stockpiles, borrow areas, and spoil shall be shown on the plans and shall be subject to the provisions of this Standard and Specifications.
10. All disturbed areas shall be stabilized structurally or vegetatively in compliance with the Permanent Construction Area Planting Standard on page 4.42.
4. Areas to be filled shall be cleared, grubbed, and stripped of topsoil to remove trees, vegetation, roots, or other objectionable material.
5. Areas that are to be topsoiled shall be scarified to a minimum depth of four inches prior to placement of topsoil.
6. All fills shall be compacted as required to reduce erosion, slippage, settlement, subsidence, or other related problems. Fill intended to support buildings, structures, and conduits, etc., shall be compacted in accordance with local requirements or codes.
7. All fill shall be placed and compacted in layers not to exceed 9 inches in thickness.
8. Except for approved landfills or nonstructural fills, fill material shall be free of frozen particles, brush, roots, sod, or other foreign objectionable materials that would interfere with, or prevent, construction of satisfactory fills.
9. Frozen material or soft, mucky or highly compressible materials shall not be incorporated into fill slopes or structural fills.
10. Fill shall not be placed on saturated or frozen surfaces.
11. All benches shall be kept free of sediment during all phases of development.
12. Seeps or springs encountered during construction shall be handled in accordance with the Standard and Specification for Subsurface Drain on page 3.48 or other approved methods.
13. All graded areas shall be permanently stabilized immediately following finished grading.
14. Stockpiles, borrow areas, and spoil areas shall be shown on the plans and shall be subject to the provisions of this Standard and Specifications.

Construction Specifications

See Figures 4.9 and 4.10 for details.

1. All graded or disturbed areas, including slopes, shall be protected during clearing and construction in accordance with the erosion and sediment control plan until they are adequately stabilized.
2. All erosion and sediment control practices and measures shall be constructed, applied and maintained in accordance with the erosion and sediment control plan and these standards.
3. Topsoil required for the establishment of vegetation shall be stockpiled in amount necessary to complete finished grading of all exposed areas.



Figure 4.9
Typical Section of Serrated Cut Slope

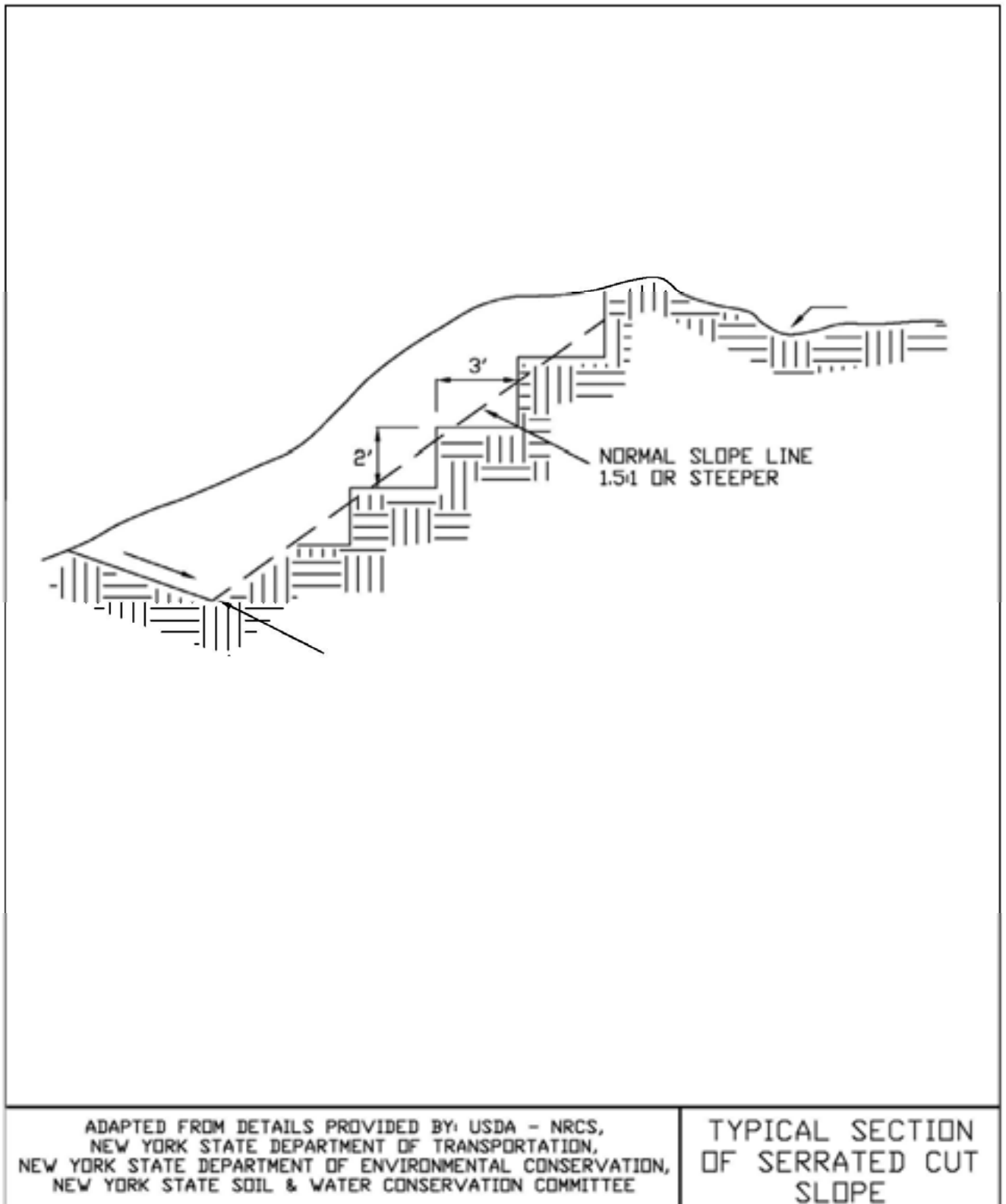

**Figure 4.10
Landgrading**

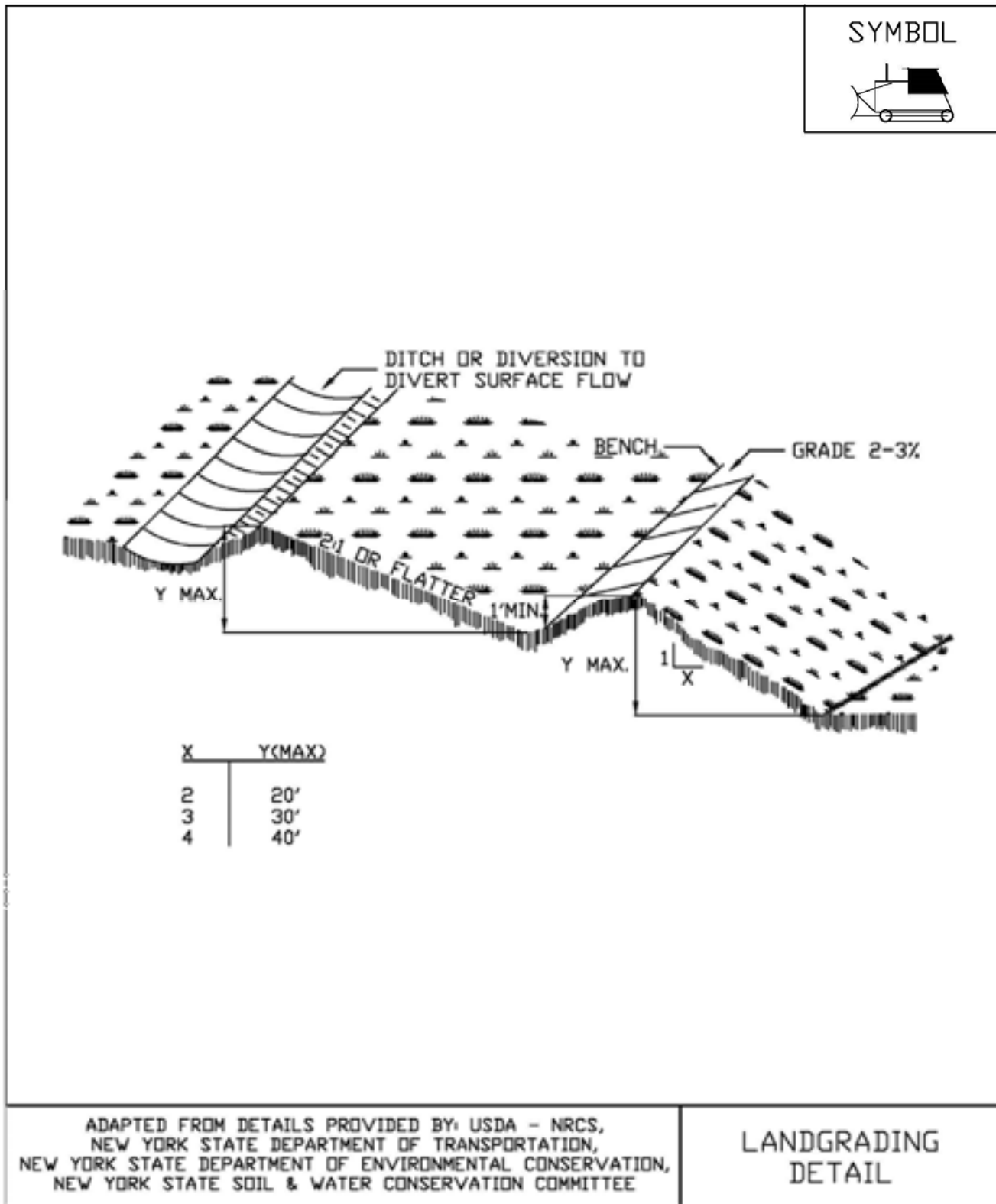

Figure 4.11
Landgrading - Construction Specifications

<u>CONSTRUCTION SPECIFICATIONS</u>	
<ol style="list-style-type: none"> 1. ALL GRADED OR DISTURBED AREAS INCLUDING SLOPES SHALL BE PROTECTED DURING CLEARING AND CONSTRUCTION IN ACCORDANCE WITH THE APPROVED EROSION AND SEDIMENT CONTROL PLAN UNTIL THEY ARE PERMANENTLY STABILIZED. 2. ALL SEDIMENT CONTROL PRACTICES AND MEASURES SHALL BE CONSTRUCTED, APPLIED AND MAINTAINED IN ACCORDANCE WITH THE APPROVED EROSION AND SEDIMENT CONTROL PLAN. 3. TOPSOIL REQUIRED FOR THE ESTABLISHMENT OF VEGETATION SHALL BE STOCKPILED IN AMOUNT NECESSARY TO COMPLETE FINISHED GRADING OF ALL EXPOSED AREAS. 4. AREAS TO BE FILLED SHALL BE CLEARED, GRUBBED, AND STRIPPED OF TOPSOIL TO REMOVE TREES, VEGETATION, ROOTS OR OTHER OBJECTIONABLE MATERIAL. 5. AREAS WHICH ARE TO BE TOPSOILED SHALL BE SCARIFIED TO A MINIMUM DEPTH OF FOUR INCHES PRIOR TO PLACEMENT OF TOPSOIL. 6. ALL FILLS SHALL BE COMPACTED AS REQUIRED TO REDUCE EROSION, SLIPPAGE, SETTLEMENT, SUBSIDENCE OR OTHER RELATED PROBLEMS. FILL INTENDED TO SUPPORT BUILDINGS, STRUCTURES AND CONDUITS, ETC. SHALL BE COMPACTED IN ACCORDANCE WITH LOCAL REQUIREMENTS OR CODES. 7. ALL FILL SHALL BE PLACED AND COMPACTED IN LAYERS NOT TO EXCEED 9 INCHES IN THICKNESS. 8. EXCEPT FOR APPROVED LANDFILLS, FILL MATERIAL SHALL BE FREE OF FROZEN PARTICLES, BRUSH, ROOTS, SOD, OR OTHER FOREIGN OR OTHER OBJECTIONABLE MATERIALS THAT WOULD INTERFERE WITH OR PREVENT CONSTRUCTION OF SATISFACTORY FILLS. 9. FROZEN MATERIALS OR SOFT, MUCKY OR HIGHLY COMPRESSIBLE MATERIALS SHALL NOT BE INCORPORATED IN FILLS. 10. FILL SHALL NOT BE PLACED ON SATURATED OR FROZEN SURFACES. 11. ALL BENCHES SHALL BE KEPT FREE OF SEDIMENT DURING ALL PHASES OF DEVELOPMENT. 12. SEEPS OR SPRINGS ENCOUNTERED DURING CONSTRUCTION SHALL BE HANDLED IN ACCORDANCE WITH THE STANDARD AND SPECIFICATION FOR SUBSURFACE DRAIN OR OTHER APPROVED METHOD. 13. ALL GRADED AREAS SHALL BE PERMANENTLY STABILIZED IMMEDIATELY FOLLOWING FINISHED GRADING. 14. STOCKPILES, BORROW AREAS AND SPOIL AREAS SHALL BE SHOWN ON THE PLANS AND SHALL BE SUBJECT TO THE PROVISIONS OF THIS STANDARD AND SPECIFICATION. 	
ADAPTED FROM DETAILS PROVIDED BY: USDA - NRCS, NEW YORK STATE DEPARTMENT OF TRANSPORTATION, NEW YORK STATE DEPARTMENT OF ENVIRONMENTAL CONSERVATION, NEW YORK STATE SOIL & WATER CONSERVATION COMMITTEE	LANDGRADING SPECIFICATIONS

STANDARD AND SPECIFICATIONS FOR LOOSE STABILIZATION BLANKETS



Definition and Scope

Blankets of various materials placed pneumatically, hydraulically, or other means on a prepared planting area or a critical area where existing vegetation can remain to reduce rain splash and sheet erosion and promote vegetative stabilization.

Conditions Where Practice Applies

Loose blankets are an appropriate stabilization practice for any soil surface that is rocky, frozen, flat, or steep. They can be used on streambanks, road cuts and embankments, and construction site areas where stormwater runoff occurs as sheet flow. They should not be used in areas of concentrated flow.

Design Criteria

Compost Blanket

Material: The compost infill shall be well decomposed (matured at least 3 months), weed-free, organic matter. It shall be aerobically composted, possess no objectionable odors, and contain less than 1%, by dry weight, of man-made foreign matter. The physical parameters of the compost shall meet the standards listed in Table 5.2 - Compost Standards Table. **Note: All biosolids composts produced in New York State (or approved for importation) must meet NYS DEC's 6 NYCRR Part 360 (Soild Waste Management Facilities) requirements. The Part 360 requirements are equal to or more stringent than 40 CFR Part 503 which ensure safe standards for pathogen reduction and heavy metal content. When using compost blankets adjacent to surface waters, the compost should have a low nutrient value.**

Placement: The method of application and depth of compost depend upon site conditions. Vegetation of the compost blanket is generally archived by incorporating seed into the compost before it is applied. However, seeding may occur after the application if needed.

The compost application rate will be in accordance with the following table. Compost is not recommended for slopes steeper than 2H:1V. Slopes with problem soils and more runoff will require greater application rates.

Compost Application Rates		
Slope Length (ft)	<3H:1V Slopes	3H:1V to 2H:1V Slopes
20 or less	270 cy/acre (2" Layer)	540 cy/acre (4" Layer)
20 to 60	405 cy/acre (3" Layer)	675 cy/acre (5" Layer)
60 to 100	540 cy/acre (4" Layer)	810 cy/acre (6" Layer)*
* For slopes between 2H:1V and 1H:1V use this rate with a max. slope length of 40 ft.		

Construction Specifications

1. Compost shall be placed evenly and must provide 100% soil coverage (no soil visible). On highly unstable soils, use compost in conjunction with appropriate structural measures.
2. Spread the compost uniformly to the design thickness by hand or mechanically (e.g. with a manure spreader, front end loader, dozer, pneumatic blower, etc.) and then track (compact) the compost layer using a bulldozer or other appropriate equipment.
3. When using a pneumatic (blower) unit, shoot the compost directly at soil, to provide a tighter interface between the soil and compost and prevent water from moving between the two layers.
4. Apply compost layer approximately 3 feet beyond the top of the slope or overlap it into existing vegetation.
5. Follow by seeding or ornamental planting as specified.
6. When planting immediate grass, wildflower, or legume seeding or ornamental planting, use only a well composted product that contains no substances toxic to plants.

7. Very coarse composts should be avoided if the slope is to be landscaped or seeded, as it will make planting and crop establishment more difficult. Composts containing fibrous particles that range in size produce a more stable mat.

Hydraulically Applied Blankets

These blankets are formed by mixing different types of materials with water and are then applied using standard hydroseeding equipment. These blankets should not be used in areas of concentrated flow such as ditches and channels.

- A. **Bonded Fiber Matrix (BFM)** - This method makes use of a cross-linked hydrocolloid tackifier to bond thermally processed wood fibers. Application rates vary according to site conditions. For slopes up to 3H:1V the BFM should be applied at a rate of 3,000 lb/acre. Steeper slopes may need as much as 4,000 lb/acre in accordance with the manufacturer's recommendations.

BFMs should only be used when no rain is forecast for at least 48 hours following the application. This is to allow the tackifier sufficient time to cure properly. Once properly applied, a BFM is very effective in preventing accelerated erosion. **Bonded Fiber Matrix should not be applied between September 30 and April 1 to allow for proper curing of the polymer.**

- B. **Flexible Growth Medium (FGM)** - This method has the added component of 1/2 inch long, crimped manmade fibers which add a mechanical bond to the chemical bond provided by BFMs. This increases the blanket's resistance to both raindrop impact and erosion due to runoff. Unlike BFMs, a flexible growth medium typically does not require a curing time to be effective. Properly applied, an FGM is also very effective.

There is no need to smooth the slope prior to application. In fact some roughening of the surface (either natural or mechanically induced) is preferable. However, large rocks (≥ 9 inches) and existing rills should be removed prior to application. Mixing and application rates should follow manufacturer's recommendations.

- C. **Polymer Stabilized Fiber Matrix (PSFM)** - PSFMs make use of a linear soil stabilization tackifier that works directly on soil to maintain soil structure, maintain pore space capacity and flocculate dislodged sediment that will significantly reduce runoff turbidity. PSFMs can be used in re-vegetation applications and for site winterization and/or dormant seeding - fall planting for spring germination - applications. Application rates vary according to site conditions and

should be in accordance with manufacturers recommendations.

Construction Specifications

BFMs, FGMs and PSFMs are typically applied in two stages. Unless specifically recommended to be applied in one application by the manufacturer, the seed mixture and soil amendments should be applied first. If the seed is applied at the same time as the hydraulically applied blankets, the bonded fibers may keep the seed from making sufficient contact with the soil to germinate. After the seed mixture is applied, the hydraulically applied blankets should be sprayed over the area at the required application rate, according to the manufactures recommendations.



STANDARD AND SPECIFICATIONS FOR MULCHING



Definition and Scope

Applying coarse plant residue or chips, or other suitable materials, to cover the soil surface to provide initial erosion control while a seeding or shrub planting is establishing. Mulch will conserve moisture and modify the surface soil temperature and reduce fluctuation of both. Mulch will prevent soil surface crusting and aid in weed control. Mulch can also be used alone for temporary stabilization in non-growing months. Use of stone as a mulch could be more permanent and should not be limited to non-growing months.

Conditions Where Practice Applies

On soils subject to erosion and on new seedings and shrub plantings. Mulch is useful on soils with low infiltration rates by retarding runoff.

Criteria

Site preparation prior to mulching requires the installation of necessary erosion control or water management practices and drainage systems.

Slope, grade and smooth the site to fit needs of selected mulch products.

Remove all undesirable stones and other debris to meet the needs of the anticipated land use and maintenance required.

Apply mulch after soil amendments and planting is accomplished or simultaneously if hydroseeding is used.

Select appropriate mulch material and application rate or material needs. Hay mulch shall not be used in wetlands or in areas of permanent seeding. Clean straw mulch is preferred alternative in wetland application. Determine local availability.

Select appropriate mulch anchoring material.

NOTE: The best combination for grass/legume establishment is straw (cereal grain) mulch applied at 2 ton/acre (90 lbs./1000sq.ft.) and anchored with wood fiber mulch (hydromulch) at 500 – 750 lbs./acre (11 – 17 lbs./1000 sq. ft.). The wood fiber mulch must be applied through a hydroseeder immediately after mulching.



Table 4.2
Guide to Mulch Materials, Rates, and Uses

Mulch Material	Quality Standards	per 1000 Sq. Ft.	per Acre	Depth of Application	Remarks
Wood chips or shavings	Air-dried. Free of objectionable coarse material	500-900 lbs.	10-20 tons	2-7"	Used primarily around shrub and tree plantings and recreation trails to inhibit weed competition. Resistant to wind blowing. Decomposes slowly.
Wood fiber cellulose (partly digested wood fibers)	Made from natural wood usually with green dye and dispersing agent	50 lbs.	2,000 lbs.	—	Apply with hydromulcher. No tie down required. Less erosion control provided than 2 tons of hay or straw.
Gravel, Crushed Stone or Slag	Washed; Size 2B or 3A—1 1/2"	9 cu. yds.	405 cu. yds.	3"	Excellent mulch for short slopes and around plants and ornamentals. Use 2B where subject to traffic. (Approximately 2,000 lbs./cu. yd.). Frequently used over filter fabric for better weed control.
Hay or Straw	Air-dried; free of undesirable seeds & coarse materials	90-100 lbs. 2-3 bales	2 tons (100-120 bales)	cover about 90% surface	Use small grain straw where mulch is maintained for more than three months. Subject to wind blowing unless anchored. Most commonly used mulching material. Provides the best micro-environment for germinating seeds.
Jute twisted yarn	Undyed, unbleached plain weave. Warp 78 ends/yd., Weft 41 ends/yd. 60-90 lbs./roll	48" x 50 yds. or 48" x 75 yds.	—	—	Use without additional mulch. Tie down as per manufacturers specifications. Good for center line of concentrated water flow.
Excelsior wood fiber mats	Interlocking web of excelsior fibers with photodegradable plastic netting	4' x 112.5' or 8' x 112.5'.	—	—	Use without additional mulch. Excellent for seeding establishment. Anchor as per manufacturers specifications. Approximately 72 lbs./roll for excelsior with plastic on both sides. Use two sided plastic for centerline of waterways.
Straw or coconut fiber, or combination	Photodegradable plastic net on one or two sides	Most are 6.5 ft. x 3.5 ft.	81 rolls	—	Designed to tolerate higher velocity water flow, centerlines of waterways, 60 sq. yds. per roll.

Table 4.3
Mulch Anchoring Guide

Anchoring Method or Material	Kind of Mulch to be Anchored	How to Apply
1. Peg and Twine	Hay or straw	After mulching, divide areas into blocks approximately 1 sq. yd. in size. Drive 4-6 pegs per block to within 2" to 3" of soil surface. Secure mulch to surface by stretching twine between pegs in criss-cross pattern on each block. Secure twine around each peg with 2 or more tight turns. Drive pegs flush with soil. Driving stakes into ground tightens the twine.
2. Mulch netting	Hay or straw	Staple the light-weight paper, jute, wood fiber, or plastic nettings to soil surface according to manufacturer's recommendations. Should be biodegradable. Most products are not suitable for foot traffic.
3. Wood cellulose fiber	Hay or straw	Apply with hydroseeder immediately after mulching. Use 500 lbs. wood fiber per acre. Some products contain an adhesive material ("tackifier"), possibly advantageous.
4. Mulch anchoring tool	Hay or straw	Apply mulch and pull a mulch anchoring tool (blunt, straight discs) over mulch as near to the contour as possible. Mulch material should be "tucked" into soil surface about 3".
5. Tackifier	Hay or straw	Mix and apply polymeric and gum tackifiers according to manufacturer's instructions. Avoid application during rain. A 24-hour curing period and a soil temperature higher than 45 ^o Fahrenheit are required.

STANDARD AND SPECIFICATIONS FOR PERMANENT CONSTRUCTION AREA PLANTING



Definition & Scope

Establishing **permanent** grasses with other forbs and/or shrubs to provide a minimum 80% perennial vegetative cover on areas disturbed by construction and critical areas to reduce erosion and sediment transport. Critical areas may include but are not limited to steep excavated cut or fill slopes as well as eroding or denuded natural slopes and areas subject to erosion.

Conditions Where Practice Applies

This practice applies to all disturbed areas void of, or having insufficient, cover to prevent erosion and sediment transport. See additional standards for special situations such as sand dunes and sand and gravel pits.

Criteria

All water control measures will be installed as needed prior to final grading and seedbed preparation. Any severely compacted sections will require chiseling or disking to provide an adequate rooting zone, to a minimum depth of 12", see Soil Restoration Standard. The seedbed must be prepared to allow good soil to seed contact, with the soil not too soft and not too compact. Adequate soil moisture must be present to accomplish this. If surface is powder dry or sticky wet, postpone operations until moisture changes to a favorable condition. If seeding is accomplished within 24 hours of final grading, additional scarification is generally not needed, especially on ditch or stream banks. Remove all stones and other debris from the surface that are greater than 4 inches, or that will interfere with future mowing or maintenance.

Soil amendments should be incorporated into the upper 2 inches of soil when feasible. **The soil should be tested to determine the amounts of amendments needed.** Apply

ground agricultural limestone to attain a pH of 6.0 in the upper 2 inches of soil. If soil must be fertilized before results of a soil test can be obtained to determine fertilizer needs, apply commercial fertilizer at 600 lbs. per acre of 5-5-10 or equivalent. If manure is used, apply a quantity to meet the nutrients of the above fertilizer. This requires an appropriate manure analysis prior to applying to the site. Do not use manure on sites to be planted with birdsfoot trefoil or in the path of concentrated water flow.

Seed mixtures may vary depending on location within the state and time of seeding. Generally, warm season grasses should only be seeded during early spring, April to May. These grasses are primarily used for vegetating excessively drained sands and gravels. See Standard and Specification for Sand and Gravel Mine Reclamation. Other grasses may be seeded any time of the year when the soil is not frozen and is workable. When legumes such as birdsfoot trefoil are included, spring seeding is preferred. See Table 4.4, "Permanent Construction Area Planting Mixture Recommendations" for additional seed mixtures.

<u>General Seed Mix:</u>	Variety	lbs./acre	lbs/1000 sq. ft.
Red Clover ¹ <u>OR</u>	Acclaim, Rally, Red Head II, Renegade	8 ²	0.20
Common white clover ¹	Common	8	0.20
<u>PLUS</u>			
Creeping Red Fescue	Common	20	0.45
<u>PLUS</u>			
Smooth Bromegrass <u>OR</u>	Common	2	0.05
Ryegrass (perennial)	Pennfine/Linn	5	0.10
¹ add inoculant immediately prior to seeding ² Mix 4 lbs each of Empire and Pardee OR 4 lbs of Birdsfoot and 4 lbs white clover per acre. All seeding rates are given for Pure Live Seed (PLS)			

Pure Live Seed, or (PLS) refers to the amount of live seed in a lot of bulk seed. Information on the seed bag label includes the type of seed, supplier, test date, source of seed, purity, and germination. Purity is the percentage of pure seed. Germination is the percentage of pure seed that will produce normal plants when planted under favorable conditions.

To compute Pure Live Seed multiply the “germination percent” times the “purity” and divide that by 100 to get Pure Live Seed.

$$\text{Pure Live Seed (PLS)} = \frac{\% \text{ Germination} \times \% \text{ Purity}}{100}$$

For example, the PLS for a lot of Kentucky Blue grass with 75% purity and 96% germination would be calculated as follows:

$$\frac{(96) \times (75)}{100} = 72\% \text{ Pure Live Seed}$$

For 10lbs of PLS from this lot =

$$\frac{10}{0.72} = 13.9 \text{ lbs}$$

Therefore, 13.9 lbs of seed is the actual weight needed to meet 10lbs PSL from this specific seed lot.

Time of Seeding: The optimum timing for the general seed mixture is early spring. Permanent seedings may be made any time of year if properly mulched and adequate moisture is provided. Late June through early August is not a good time to seed, but may facilitate covering the land without additional disturbance if construction is completed. Portions of the seeding may fail due to drought and heat. These areas may need reseeding in late summer/fall or the following spring.

Method of seeding: Broadcasting, drilling, cultipack type seeding, or hydroseeding are acceptable methods. Proper soil to seed contact is key to successful seedings.

Mulching: Mulching is essential to obtain a uniform stand of seeded plants. Optimum benefits of mulching new seedings are obtained with the use of small grain straw applied at a rate of 2 tons per acre, and anchored with a netting or tackifier. See the Standard and Specifications for Mulching for choices and requirements.

Irrigation: Watering may be essential to establish a new seeding when a drought condition occurs shortly after a new seeding emerges. Irrigation is a specialized practice and care must be taken not to exceed the application rate for the soil or subsoil. When disconnecting irrigation pipe, be sure pipes are drained in a safe manor, not creating an erosion concern.



80% Perennial Vegetative Cover



50% Perennial Vegetative Cover

**Table 4.4
Permanent Construction Area Planting Mixture Recommendations**

Seed Mixture	Variety	Rate in lbs./acre (PLS)	Rate in lbs./1,000 ft ²
Mix #1			
Creeping red fescue	Ensylva, Pennlawn, Boreal	10	.25
Perennial ryegrass	Pennfine, Linn	10	.25
*This mix is used extensively for shaded areas.			
Mix #2			
Switchgrass	Shelter, Pathfinder, Trailblazer, or Blackwell	20	.50
*This rate is in pure live seed, this would be an excellent choice along the upland edge of a wetland to filter runoff and provide wildlife benefits. In areas where erosion may be a problem, a companion seeding of sand lovegrass should be added to provide quick cover at a rate of 2 lbs. per acre (0.05 lbs. per 1000 sq. ft.).			
Mix #3			
Switchgrass	Shelter, Pathfinder, Trailblazer, or Blackwell	4	.10
Big bluestem	Niagara	4	.10
Little bluestem	Aldous or Camper	2	.05
Indiangrass	Rumsey	4	.10
Coastal panicgrass	Atlantic	2	.05
Sideoats grama	El Reno or Trailway	2	.05
Wildflower mix		.50	.01
*This mix has been successful on sand and gravel plantings. It is very difficult to seed without a warm season grass seeder such as a Truax seed drill. Broadcasting this seed is very difficult due to the fluffy nature of some of the seed, such as bluestems and indiangrass.			
Mix #4			
Switchgrass	Shelter, Pathfinder, Trailblazer, or Blackwell	10	.25
Coastal panicgrass	Atlantic	10	.25
*This mix is salt tolerant, a good choice along the upland edge of tidal areas and roadsides.			
Mix #5			
Saltmeadow cordgrass (<i>Spartina patens</i>)—This grass is used for tidal shoreline protection and tidal marsh restoration. It is planted by vegetative stem divisions.			
'Cape' American beachgrass can be planted for sand dune stabilization above the saltmeadow cordgrass zone.			
Mix #6			
Creeping red fescue	Ensylva, Pennlawn, Boreal	20	.45
Chewings Fescue	Common	20	.45
Perennial ryegrass	Pennfine, Linn	5	.10
Red Clover	Common	10	.45
*General purpose erosion control mix. Not to be used for a turf planting or play grounds.			

STANDARD AND SPECIFICATIONS FOR SOIL RESTORATION



Definition & Scope

The decompaction of areas of a development site or construction project where soils have been disturbed to recover the original properties and porosity of the soil; thus providing a sustainable growth medium for vegetation, reduction of runoff and filtering of pollutants from stormwater runoff.

Conditions Where Practice Applies

Soil restoration is to be applied to areas whose heavy construction traffic is done and final stabilization is to begin. This is generally applied in the cleanup, site restoration, and landscaping phase of construction followed by the permanent establishment of an appropriate ground cover to maintain the soil structure. Soil restoration measures should be applied over and adjacent to any runoff reduction practices to achieve design performance.



Design Criteria

1. Soil restoration areas will be designated on the plan views of areas to be disturbed.

2. Soil restoration will be completed in accordance with Table 4.6 on page 4.53.

Specification for Full Soil Restoration

During periods of relatively low to moderate subsoil moisture, the disturbed subsoils are returned to rough grade and the following Soil Restoration steps applied:

1. Apply 3 inches of compost over subsoil. The compost shall be well decomposed (matured at least 3 months), weed-free, organic matter. It shall be aerobically composted, possess no objectionable odors, and contain less than 1%, by dry weight, of man-made foreign matter. The physical parameters of the compost shall meet the standards listed in Table 5.2 - Compost Standards Table, except for "Particle Size" 100% will pass the 1/2" sieve. **Note: All biosolids compost produced in New York State (or approved for importation) must meet NYS DEC's 6 NYCRR Part 360 (Solid Waste Management Facilities) requirements. The Part 360 requirements are equal to or more stringent than 40 CFR Part 503 which ensure safe standards for pathogen reduction and heavy metals content.**



2. Till compost into subsoil to a depth of at least 12 inches using a cat-mounted ripper, tractor mounted disc, or tiller, to mix and circulate air and compost into the subsoil.
3. Rock-pick until uplifted stone/rock materials of four inches and larger size are cleaned off the site.
4. Apply topsoil to a depth of 6 inches.
5. Vegetate as required by the seeding plan. Use appropriate ground cover with deep roots to maintain the soil structure.
6. Topsoil may be manufactured as a mixture or a mineral component and organic material such as compost.

At the end of the project an inspector should be able to push a 3/8” metal bar 12 inches into the soil just with body weight. This should not be performed within the drip line of any existing trees or over utility installations that are within 24 inches of the surface.

Maintenance

Keep the site free of vehicular and foot traffic or other weight loads. Consider pedestrian footpaths.

**Table 4.6
Soil Restoration Requirements**

Type of Soil Disturbance	Soil Restoration Requirement		Comments/Examples
No soil disturbance	Restoration not permitted		Preservation of Natural Features
Minimal soil disturbance	Restoration not required		Clearing and grubbing
Areas where topsoil is stripped only - no change in grade	HSG A&B	HSG C&D	Protect area from any ongoing construction activities.
	Apply 6 inches of topsoil	Aerate* and apply 6 inches of topsoil	
Areas of cut or fill	HSG A&B	HSG C&D	
	Aerate* and apply 6 inches of topsoil	Apply full Soil Restoration**	
Heavy traffic areas on site (especially in a zone 5-25 feet around buildings but not within a 5 foot perimeter around foundation walls)	Apply full Soil Restoration (decompaction and compost enhancement)		
Areas where Runoff Reduction and/or Infiltration practices are applied	Restoration not required, but may be applied to enhance the reduction specified for appropriate practices.		Keep construction equipment from crossing these areas. To protect newly installed practice from any ongoing construction activities construct a single phase operation fence area
Redevelopment projects	Soil Restoration is required on redevelopment projects in areas where existing impervious area will be converted to pervious area.		
* Aeration includes the use of machines such as tractor-drawn implements with coulters making a narrow slit in the soil, a roller with many spikes making indentations in the soil, or prongs which function like a mini-subsoiler. ** Per “Deep Ripping and De-compaction, DEC 2008”.			

STANDARD AND SPECIFICATIONS FOR SURFACE ROUGHENING



Definition & Scope

Roughening a bare soil surface whether through creating horizontal grooves across a slope, stair-stepping, or tracking with construction equipment to aid the establishment of vegetative cover from seed, to reduce runoff velocity and increase infiltration, and to reduce erosion and provide for trapping of sediment.

Conditions Where Practice Applies

All construction slopes require surface roughening to facilitate stabilization with vegetation, particularly slopes steeper than 3:1.

Design Criteria

There are many different methods to achieve a roughened soil surface on a slope. No specific design criteria is required. However, the selection of the appropriate method depends on the type of slope. Methods include tracking, grooving, and stair-stepping. Steepness, mowing requirements, and/or a cut or fill slope operation are all factors considered in choosing a roughening method.

Construction Specifications

1. Cut Slope, No mowing.
 - A. Stair-step grade or groove cut slopes with a gradient steeper than 3:1 (Figure 4.18).
 - B. Use stair-step grading on any erodible material soft enough to be ripped with a bulldozer. Slopes of soft rock with some soil are particularly suited to stair-step grading.

- C. Make the vertical cut distance less than the horizontal distance, and slightly slope the horizontal position of the “step” to the vertical wall.
- D. Do not make vertical cuts more than 2 feet in soft materials or 3 feet in rocky materials.

Grooving uses machinery to create a series of ridges and depressions that run perpendicular to the slope following the contour. Groove using any appropriate implement that can be safely operated on the slope, such as disks, tillers, spring harrows, or the teeth of a front-end loader bucket. Do not make the grooves less than 3 inches deep or more than 15 inches apart.

2. Fill Slope, No mowing

- A. Place fill to create slopes with a gradient no steeper than 2:1 in lifts 9 inches or less and properly compacted. Ensure the face of the slope consists of loose, uncompacted fill 4 to 6 inches deep. Use grooving as described above to roughen the slope, if necessary.
- B. Do not back blade or scrape the final slope face.

3. Cuts/Fills, Mowed Maintenance

- A. Make mowed slopes no steeper than 3:1.
- B. Roughen these areas to shallow grooves by normal tilling, disking, harrowing, or use of cultipacker-seeder. Make the final pass of such tillage equipment on the contour.
- C. Make grooves at least 1 inch deep and a maximum of 10 inches apart.
- D. Excessive roughness is undesirable where mowing is planned.

Tracking should be used primarily in sandy soils to avoid undue compaction of the soil surface. Tracking is generally not as effective as the other roughening methods described. (It has been used as a method to track down mulch.) Operate tracked machinery up and down the slope to leave horizontal depressions in the soil. Do not back-blade during the final grading operation.

Figure 4.18
Surface Roughening

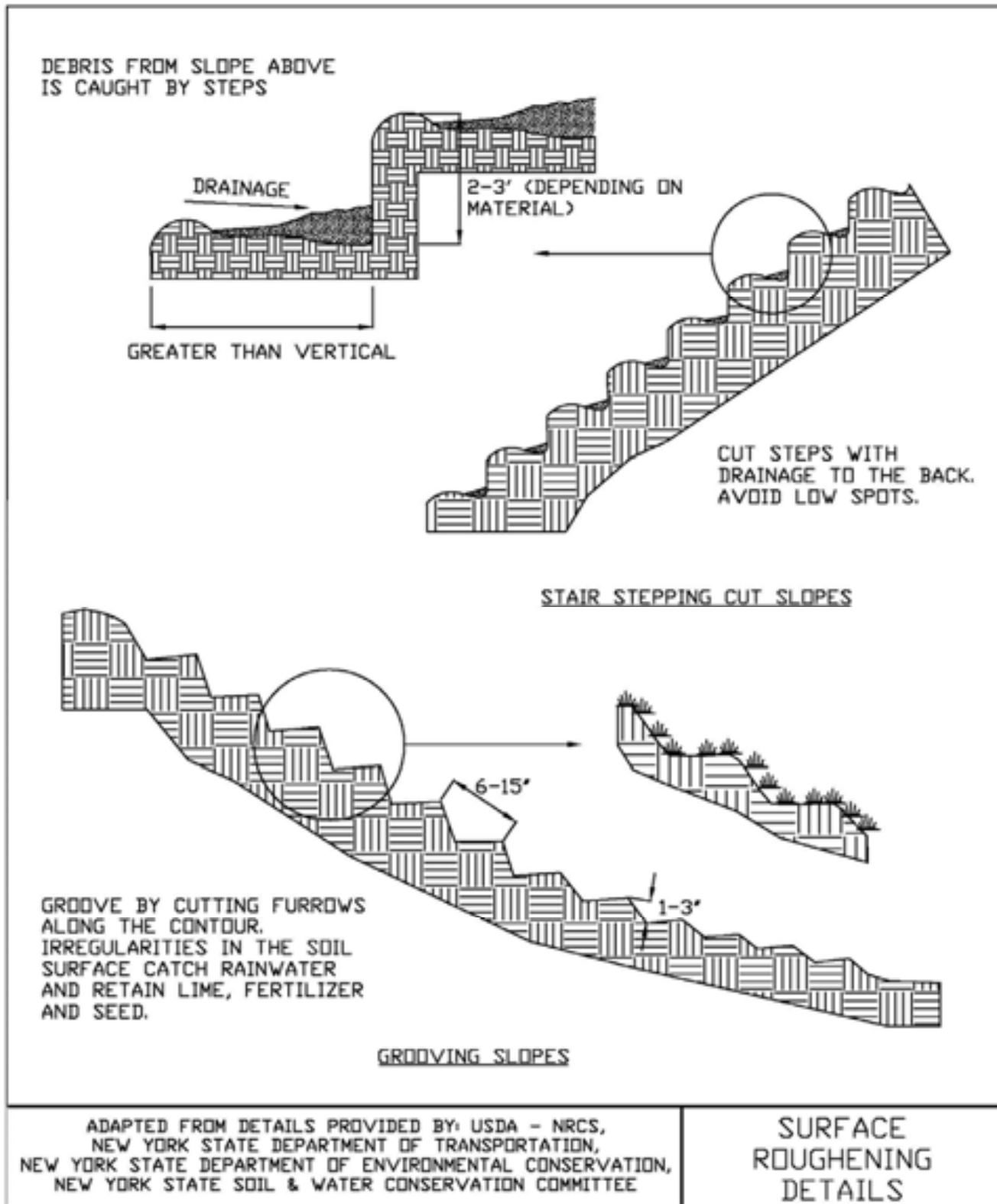

STANDARD AND SPECIFICATIONS FOR TEMPORARY CONSTRUCTION AREA SEEDING



Definition & Scope

Providing temporary erosion control protection to disturbed areas and/or localized critical areas for an interim period by covering all bare ground that exists as a result of construction activities or a natural event. Critical areas may include but are not limited to steep excavated cut or fill slopes and any disturbed, denuded natural slopes subject to erosion.

Conditions Where Practice Applies

Temporary seedings may be necessary on construction sites to protect an area, or section, where final grading is complete, when preparing for winter work shutdown, or to provide cover when permanent seedings are likely to fail due to mid-summer heat and drought. The intent is to provide temporary protective cover during temporary shutdown of construction and/or while waiting for optimal planting time.

Criteria

Water management practices must be installed as appropriate for site conditions. The area must be rough graded and slopes physically stable. Large debris and rocks are usually removed. Seedbed must be seeded within 24 hours of disturbance or scarification of the soil surface will be necessary prior to seeding.

Fertilizer or lime are not typically used for temporary seedings.

IF: Spring or summer or early fall, then seed the area with ryegrass (annual or perennial) at 30 lbs. per acre (Approximately 0.7 lb./1000 sq. ft. or use 1 lb./1000 sq. ft.).

IF: Late fall or early winter, then seed Certified 'Aroostook' winter rye (cereal rye) at 100 lbs. per acre (2.5 lbs./1000 sq. ft.).

Any seeding method may be used that will provide uniform application of seed to the area and result in relatively good soil to seed contact.

Mulch the area with hay or straw at 2 tons/acre (approx. 90 lbs./1000 sq. ft. or 2 bales). Quality of hay or straw mulch allowable will be determined based on long term use and visual concerns. Mulch anchoring will be required where wind or areas of concentrated water are of concern. Wood fiber hydromulch or other sprayable products approved for erosion control (nylon web or mesh) may be used if applied according to manufacturers' specification. Caution is advised when using nylon or other synthetic products. They may be difficult to remove prior to final seeding and can be a hazard to young wildlife species.

STANDARD AND SPECIFICATIONS FOR TOPSOILING



Definition & Scope

Spreading a specified quality and quantity of topsoil materials on graded or constructed subsoil areas to provide acceptable plant cover growing conditions, thereby reducing erosion; to reduce irrigation water needs; and to reduce the need for nitrogen fertilizer application.

Conditions Where Practice Applies

Topsoil is applied to subsoils that are droughty (low available moisture for plants), stony, slowly permeable, salty or extremely acid. It is also used to backfill around shrub and tree transplants. This standard does not apply to wetland soils.

Design Criteria

1. Preserve existing topsoil in place where possible, thereby reducing the need for added topsoil.
2. Conserve by stockpiling topsoil and friable fine textured subsoils that must be stripped from the excavated site and applied after final grading where vegetation will be established. Topsoil stockpiles must be stabilized. Stockpile surfaces can be stabilized by vegetation, geotextile or plastic covers. This can be aided by orientating the stockpile lengthwise into prevailing winds.
3. Refer to USDA Natural Resource Conservation Service soil surveys or soil interpretation record sheets for further soil texture information for selecting appropriate design topsoil depths.

Site Preparation

1. As needed, install erosion and sediment control practices such as diversions, channels, sediment traps, and stabilizing measures, or maintain if already installed.
2. Complete rough grading and final grade, allowing for depth of topsoil to be added.
3. Scarify all compact, slowly permeable, medium and fine textured subsoil areas. Scarify at approximately right angles to the slope direction in soil areas that are steeper than 5 percent. Areas that have been overly compacted shall be decompact in accordance with the Soil Restoration Standard.
4. Remove refuse, woody plant parts, stones over 3 inches in diameter, and other litter.

Topsoil Materials

1. Topsoil shall have at least 6 percent by weight of fine textured stable organic material, and no greater than 20 percent. Muck soil shall not be considered topsoil.
2. Topsoil shall have not less than 20 percent fine textured material (passing the NO. 200 sieve) and not more than 15 percent clay.
3. Topsoil treated with soil sterilants or herbicides shall be so identified to the purchaser.
4. Topsoil shall be relatively free of stones over 1 1/2 inches in diameter, trash, noxious weeds such as nut sedge and quackgrass, and will have less than 10 percent gravel.
5. Topsoil containing soluble salts greater than 500 parts per million shall not be used.
6. Topsoil may be manufactured as a mixture of a mineral component and organic material such as compost.

Application and Grading

1. Topsoil shall be distributed to a uniform depth over the area. It shall not be placed when it is partly frozen, muddy, or on frozen slopes or over ice, snow, or standing water puddles.
2. Topsoil placed and graded on slopes steeper than 5 percent shall be promptly fertilized, seeded, mulched, and stabilized by “tracking” with suitable equipment.
3. Apply topsoil in the amounts shown in Table 4.7 below:

Table 4.7 - Topsoil Application Depth		
Site Conditions	Intended Use	Minimum Topsoil Depth
1. Deep sand or loamy sand	Mowed lawn	6 in.
	Tall legumes, unmowed	2 in.
	Tall grass, unmowed	1 in.
2. Deep sandy loam	Mowed lawn	5 in.
	Tall legumes, unmowed	2 in.
	Tall grass, unmowed	none
3. Six inches or more: silt loam, clay loam, loam, or silt	Mowed lawn	4 in.
	Tall legumes, unmowed	1 in.
	Tall grass, unmowed	1 in.

STANDARD AND SPECIFICATIONS FOR BUFFER FILTER STRIP



Land Slope (%)	Minimum Filter Strip Width (ft.)
≤10	50
20	60
30	85
40	105
50	125
60	145
70	165

Definition & Scope

A **temporary/permanent** well vegetated grassed area below a disturbed area that can be used to remove sediment from runoff prior to it reaching surface waters or other designated areas of concern, such as parking lots and road pavement.

Condition Where Practice Applies

This practice is effective when the flow is in the form of sheet flow and the vegetative cover is established prior to disturbance. Surface water must be protected from sediment-laden runoff until buffer filter strip vegetation is established, and then the proposed disturbance can be undertaken. This practice is effective when the flow is in the form of sheet flow (maximum of 150 feet).

Design Criteria

1. The vegetation should be a well established perennial grass. Wooded and brushy areas are not acceptable for purposes of sediment removal.
2. The minimum buffer filter strip width for stream protection shall be in accordance with the following table:

3. The minimum buffer filter strip width to protect paved areas during construction is 20 feet.

Maintenance

If at any time the width of the buffer filter strip has been reduced by sediment deposition to half its original width or concentrated flow has developed, suitable additional practices should be installed. The erosion and sediment control plan shall include these details.

Figure 5.1
Buffer Filter Strip

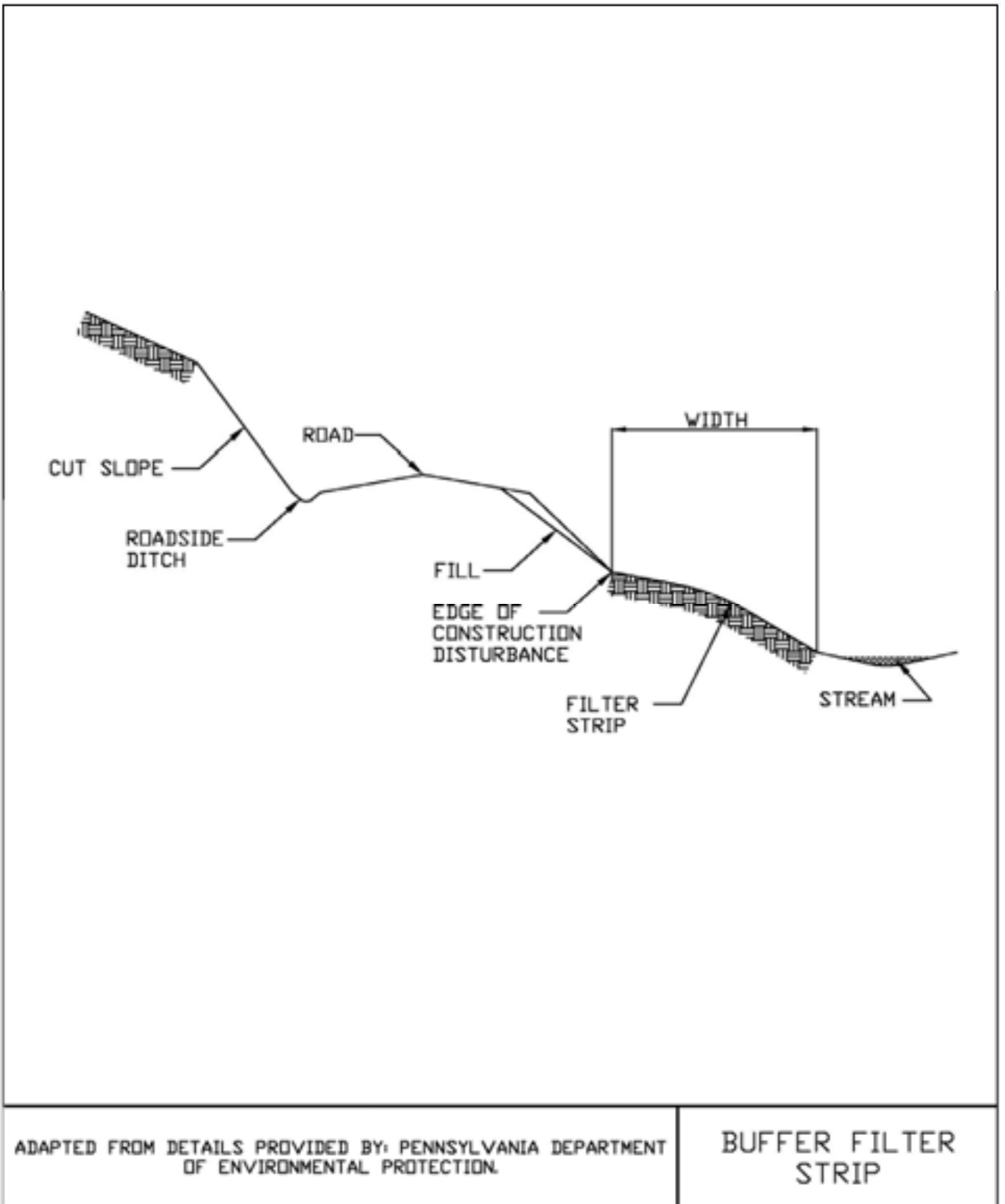

STANDARD AND SPECIFICATIONS FOR COFFERDAM STRUCTURES



Definition & Scope

A **temporary** barrier placed at a worksite to prevent water from flooding the work area so that construction can take place without discharging sediment into the water resource.

Condition Where Practice Applies

Temporary coffer dams are used to separate streams, rivers, lakes, and other sources of surface water from adjacent locations where soil disturbances are undertaken to complete construction. These barriers can be constructed of manufactured components such as geotextile/plastic tubes filled with water, portable dams formed by metal framing with a geo-membrane, or conventionally constructed earth and stone dike systems.

Design Criteria

The maximum height for this application is 10 feet. No construction activity shall commence in the area of the cofferdam until it is completed and stabilized.

Water Filled Structures

1. These structures shall be sized and installed according to the manufacturers recommendations.
2. Adequate freeboard must be provided to prevent flotation during high water events and periods of below freezing temperatures.
3. The foundation shall be prepared to provide full bottom contact prior to filling.
4. An interior dewatering system shall be designed within

the work area to manage seepage.

5. The ends of the water structures shall be anchored on the stream banks or shorelines at an elevation at least above the top of the structure.

Structural Component Dams

1. These structures shall be sized and installed in accordance with the manufacturers recommendations.
2. The foundation area for the placement of the structural steel framing and the impervious fabric membrane shall be as directed by the manufacturer or by qualified personnel.
3. Dewatering the interior of the coffer dam will be done in a manner that does not disturb the foundation area of the structural frame.
4. A minimum of 2 feet of freeboard shall be provided above the expected high water elevation.

Earthen Cofferdams

1. The earthen coffer dam shall be constructed of fill material that will preclude the transmission of water through the dam, or contain an impermeable core.
2. The minimum top width shall be 8 feet with 2:1 side slopes, and compacted in 9 inch lifts with a minimum of 4 passes of construction equipment.
3. The outside slope shall be covered with a 1 foot layer of rock riprap over a graded stone bedding or geotextile to prevent erosion of soil material into water. An alternative method is to cover the outside slope with an anchored plastic cover with a minimum thickness of 20 mil.
4. Interior work will be conducted in a manner that will not disturb or undermine the earthen coffer dam or its foundation.

Inspection and Maintenance

1. All cofferdams will be inspected daily to assure proper performance and stability as vibration from construction equipment can cause disturbance of the structures.
2. Particular attention should be given to the foundation support system at perimeter of structural component dams. Any undermined or settled areas shall be restored immediately.

3. Any holes, leaks, or torn areas in the geo-membranes or fabric shall be repaired immediately.
4. Any shifting, movement, or settling of the coffer dam shall be addressed immediately to protect workers in the construction area.
5. Inspect the interior dewatering system and ensure that the system is discharging clean water, or is being pumped to appropriate sediment control facility prior to returning to the water resource.
6. Repair or replace any loss of rock riprap or fill that may occur and assure the top of the coffer dam is level without any low spots due to settling.
7. Upon completion of the construction work, remove all excess material, accumulated sediment and debris from the work area, and remove the cofferdam in accordance with the site stabilization plan.

STANDARD AND SPECIFICATIONS FOR COMPOST FILTER SOCK



Definition & Scope

A **temporary** sediment control practice composed of a degradable geotextile mesh tube filled with compost filter media to filter sediment and other pollutants associated with construction activity to prevent their migration offsite.

Condition Where Practice Applies

Compost filter socks can be used in many construction site applications where erosion will occur in the form of sheet erosion and there is no concentration of water flowing to the sock. In areas with steep slopes and/or rocky terrain, soil conditions must be such that good continuous contact between the sock and the soil is maintained throughout its length. For use on impervious surfaces such as road pavement or parking areas, proper anchorage must be provided to prevent shifting of the sock or separation of the contact between the sock and the pavement. Compost filter socks are utilized both at the site perimeter as well as within the construction areas. These socks may be filled after placement by blowing compost into the tube pneumatically, or filled at a staging location and moved into its designed location.

Design Criteria

1. Compost filter socks will be placed on the contour with both terminal ends of the sock extended 8 feet upslope at a 45 degree angle to prevent bypass flow.
2. Diameters designed for use shall be 12" – 32" except

that 8" diameter socks may be used for residential lots to control areas less than 0.25 acres.

3. The flat dimension of the sock shall be at least 1.5 times the nominal diameter.
4. The **Maximum Slope Length** (in feet) above a compost filter sock shall not exceed the following limits:

Dia. (in.)	Slope %						
	2	5	10	20	25	33	50
8	225*	200	100	50	20	—	—
12	250	225	125	65	50	40	25
18	275	250	150	70	55	45	30
24	350	275	200	130	100	60	35
32	450	325	275	150	120	75	50

* Length in feet



5. The compost infill shall be well decomposed (matured at least 3 months), weed-free, organic matter. It shall be aerobically composted, possess no objectionable odors, and contain less than 1%, by dry weight, of man-made foreign matter. The physical parameters of the compost shall meet the standards listed in Table 5.2 - Compost Standards Table. **Note: All biosolids compost produced in New York State (or approved for importation) must meet NYS DEC's 6 NYCRR Part 360 (Solid Waste Management Facilities) requirements. The Part 360 requirements are equal to or more stringent than 40 CFR Part 503 which ensure safe standards for pathogen reduction and heavy metals content. When using compost filter socks adjacent to surface water, the compost should have a low nutrient value.**
6. The compost filter sock fabric material shall meet the

7. Compost filter socks shall be anchored in earth with 2” x 2” wooden stakes driven 12” into the soil on 10 foot centers on the centerline of the sock. On uneven terrain, effective ground contact can be enhanced by the placement of a fillet of filter media on the disturbed area side of the compost sock.
8. All specific construction details and material specifications shall appear on the erosion and sediment control constructions drawings when compost filter socks are included in the plan.
3. Socks shall be inspected weekly and after each runoff event. Damaged socks shall be repaired in the manner required by the manufacturer or replaced within 24 hours of inspection notification.
4. Biodegradable filter socks shall be replaced after 6 months; photodegradable filter socks after 1 year. Polypropylene socks shall be replaced according to the manufacturer’s recommendations.
5. Upon stabilization of the area contributory to the sock, stakes shall be removed. The sock may be left in place and vegetated or removed in accordance with the stabilization plan. For removal the mesh can be cut and the compost spread as an additional mulch to act as a soil supplement.

Maintenance

1. Traffic shall not be permitted to cross filter socks.
2. Accumulated sediment shall be removed when it reaches half the above ground height of the sock and disposed of in accordance with the plan.

Table 5.1 - Compost Sock Fabric Minimum Specifications Table

Material Type	3 mil HDPE	5 mil HDPE	5 mil HDPE	Multi-Filament Polypropylene (MFPP)	Heavy Duty Multi-Filament Polypropylene (HDMFPP)
Material Characteristics	Photodegradable	Photodegradable	Biodegradable	Photodegradable	Photodegradable
Sock Diameters	12” 18”	12” 18” 24” 32”	12” 18” 24” 32”	12” 18” 24” 32”	12” 18” 24” 32”
Mesh Opening	3/8”	3/8”	3/8”	3/8”	1/8”
Tensile Strength		26 psi	26 psi	44 psi	202 psi
Ultraviolet Stability % Original Strength (ASTM G-155)	23% at 1000 hr.	23% at 1000 hr.		100% at 1000 hr.	100% at 1000 hr.
Minimum Functional Longevity	6 months	9 months	6 months	1 year	2 years

Table 5.2 - Compost Standards Table

Organic matter content	25% - 100% (dry weight)
Organic portion	Fibrous and elongated
pH	6.0 – 8.0
Moisture content	30% - 60%
Particle size	100% passing a 1” screen and 10 - 50% passing a 3/8” screen
Soluble salt concentration	5.0 dS/m (mmhos/cm) maximum

Figure 5.2
Compost Filter Sock

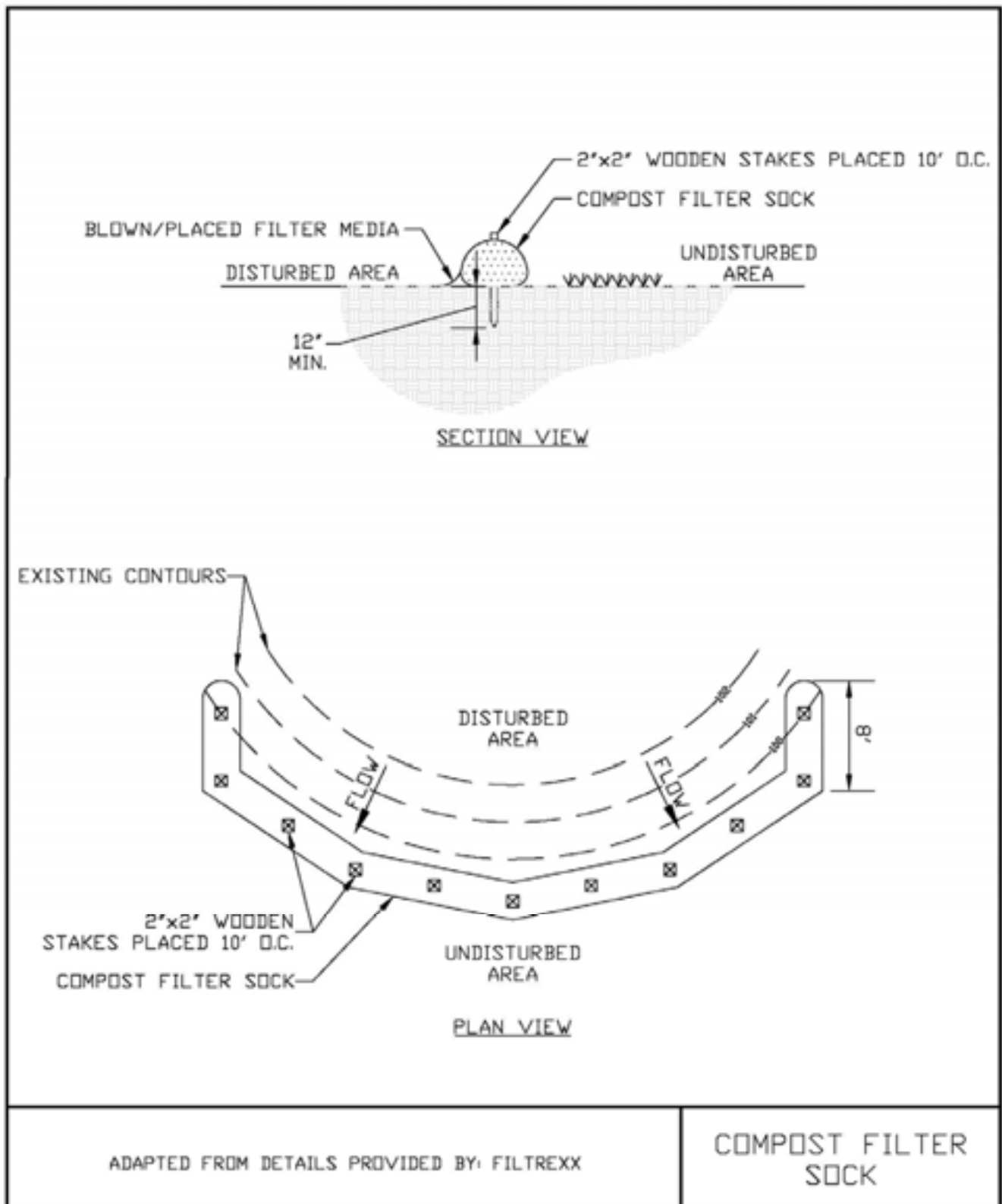

STANDARD AND SPECIFICATIONS FOR GEOTEXTILE FILTER BAG



Definition & Scope

A **temporary** portable device through which sediment laden water is pumped to trap and retain sediment prior to its discharge to drainageways or off-site.

Condition Where Practice Applies

On sites where space is limited such as urban construction or linear projects (e.g. roads and utility work) where rights-of-way are limited and larger de-silting practices are impractical.

Design Criteria

1. Location - The portable filter bag should be located to minimize interference with construction activities and pedestrian traffic. It should also be placed in a location that is vegetated, relatively level, and provides for ease of access by heavy equipment, cleanout, disposal of trapped sediment, and proper release of filtered water.

The filter bag shall also be placed at least 50 feet from all wetlands, streams or other surface waters.

2. Size - Geotextile filter bag shall be sized in accordance with the manufacturers recommendations based on the pump discharge rate.

Materials and Installation

1. The geotextile material will have the following attributes:

Minimum Grab Tensile Strength	200 lbs.
Minimum Grab Tensile Elongation	50 %
Minimum Trapezoid Tear Strength	80 lbs.
Mullen Burst Strength	380 psi
Minimum Puncture Strength	130 lbs
Apparent Opening Size	40 - 80 US sieve
Minimum UV Resistance	70%
Minimum Flow Thru Rate	70 gpm/sq ft

2. The bag shall be sewn with a double needle machine using high strength thread, double stitched "Joe" type capable of minimum roll strength of 100 lbs/inch (ASTM D4884).
3. The geotextile filter bag shall have an opening large enough to accommodate a 4 inch diameter discharge hose with an attached strap to tie off the bag to the hose to prevent back flow.
4. The geotextile shall be placed on a gravel bed 2 inches thick, a straw mat 4 inches thick, or a vegetated filter strip to allow water to flow out of the bag in all directions.

Maintenance

1. The geotextile filter bag is considered full when remaining bag flow area has been reduced by 75%. At this point, it should be replaced with a new bag.
2. Disposal may be accomplished by removing the bag to an appropriate designated upland area, cut open, remove the geotextile for disposal, and spread sediment contents and seeded and mulched according to the vegetative plan.

STANDARD AND SPECIFICATIONS FOR ROCK DAM



Definition & Scope

A rock embankment located to capture and retain sediment on the construction site and prevent sedimentation in offsite water bodies.

Conditions Where Practice Applies

The rock dam may be used instead of the standard sediment basin with barrel and riser. The rock dam is preferred when it is difficult to construct a stable, earthen embankment and rock materials are readily available. The site should be accessible for periodic sediment removal. This rock dam shall not be located in a perennial stream. The top of the dam will serve as the overflow outlet. The inside of the dam will be faced with smaller stone to reduce the rate of seepage so a sediment pool forms during runoff events.

Design Criteria

Drainage Area: The drainage area for this off stream structure is limited to 50 acres.

Location: The location of the dam should:

- provide a large area to trap sediment
- intercept runoff from disturbed areas
- be accessible to remove sediment
- not interfere with construction activities

Storage Volume: The storage volume behind the dam shall be at least 3,600 cubic feet per acre of drainage area to the dam. This volume is measured one foot below the crest of the dam.

Dam Section:

Top Width	5 feet minimum @ crest
Side Slopes	2:1 upstream slope 3:1 downstream slope
Height	6' max to spillway crest

Length of Crest: The crest length should be designed to carry the 10 yr. peak runoff with a maximum flow depth of 1 foot and 1 foot of freeboard.

Rock at the abutments should extend at least 2 feet above the spillway and be at least 2 feet thick. These rock abutments should extend at least one foot above the downstream slope to prevent abutment scour. A rock apron at least 1.5 feet thick should extend downstream from the toe of the dam a distance equal to the height of the dam to protect the outlet area from scour.

Rock Fill: The rock fill should be well graded, hard, erosion resistant stone with a minimum d_{50} size of 9 inches. A “key trench” lined with geotextile filter fabric should be installed in the soil foundation under the rock fill. The filter fabric must extend from the key trench to the downstream edge of the apron and abutments to prevent soil movement and piping under the dam.

The upstream face of the dam should be covered with a fine washed gravel (NYS-DOT #1 or #1A gravel, crushed stone or equal) a minimum 3 feet thick to reduce the drainage rate.

Trapping Efficiency: To obtain maximum trapping efficiency, design for a long detention period. Usually a minimum of eight (8) hours before the basin is completely drained. Maximize the length of travel of sediment laden water from the inlet to the drain for a minimum length to width ratio of 2 to 1 or greater. Achieve a surface area equal to 0.01 acres per cfs (inflow) based on the 10-year storm. See Figure 5.7 on page 5.18 for details.

Maintenance

Check the basin area after each rainfall event. Remove sediment and restore original volume when sediment accumulates to one-half the design volume. Check the structure for erosion, piping, and rock displacement after each significant event and replace immediately.

Remove the structure and any sediment immediately after the construction area has been permanently stabilized. All water should be removed from the basin prior to the removal of the rock dam. Sediment should be placed in designated disposal areas and not allowed to flow into streams or drainage ways during structure removal.

**Figure 5.7
Rock Dam**

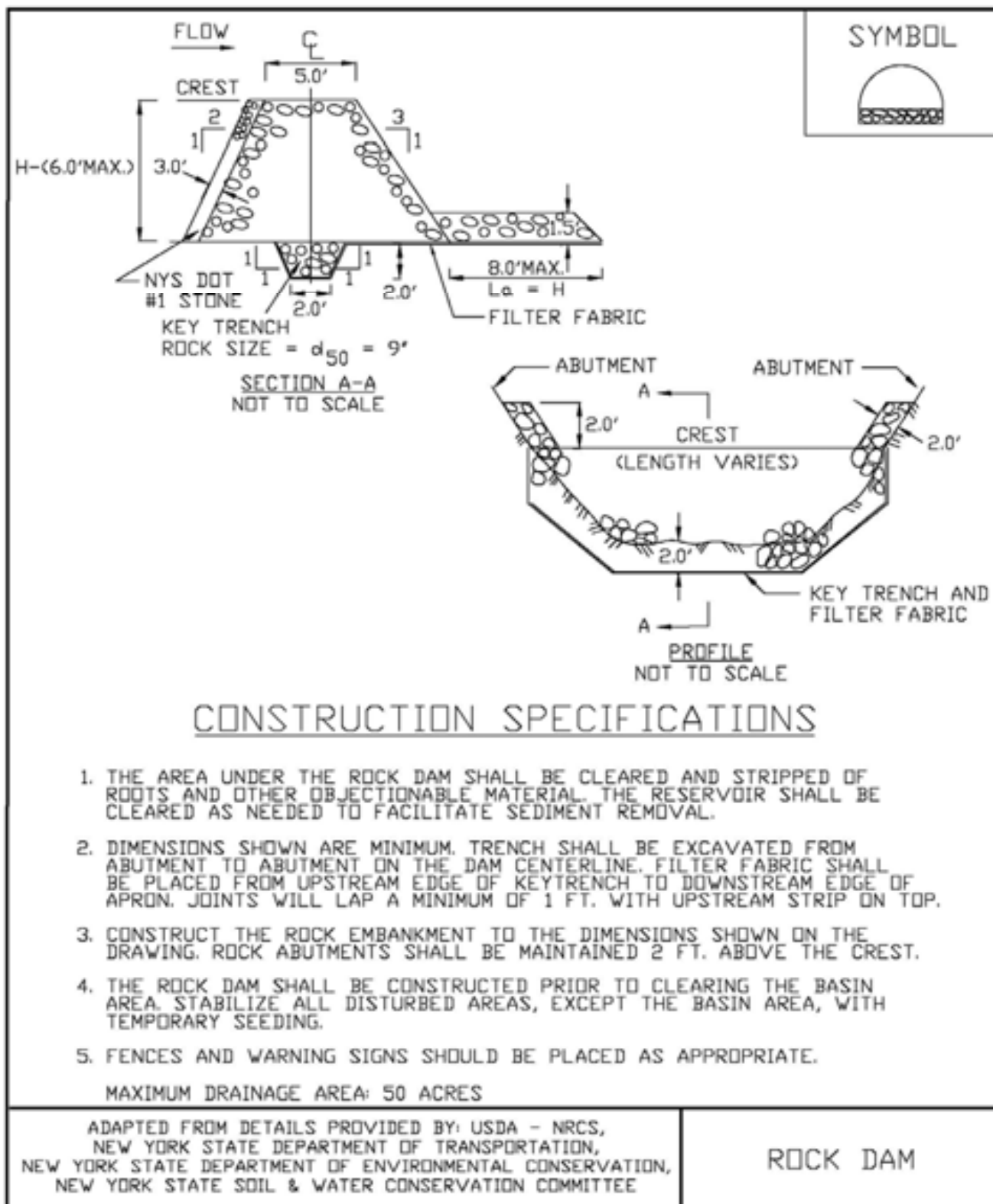

STANDARD AND SPECIFICATIONS FOR SILT FENCE



Definition & Scope

A **temporary** barrier of geotextile fabric installed on the contours across a slope used to intercept sediment laden runoff from small drainage areas of disturbed soil by temporarily ponding the sediment laden runoff allowing settling to occur. The maximum period of use is limited by the ultraviolet stability of the fabric (approximately one year).

Conditions Where Practice Applies

A silt fence may be used subject to the following conditions:

1. Maximum allowable slope length and fence length will not exceed the limits shown in the Design Criteria for the specific type of silt fence used ; and
2. Maximum ponding depth of 1.5 feet behind the fence; and
3. Erosion would occur in the form of sheet erosion; and
4. There is no concentration of water flowing to the barrier; and
5. Soil conditions allow for proper keying of fabric, or other anchorage, to prevent blowouts.

Design Criteria

1. Design computations are not required for installations of 1 month or less. Longer installation periods should be designed for expected runoff.
2. All silt fences shall be placed as close to the disturbed area as possible, but at least 10 feet from the toe of a slope steeper than 3H:1V, to allow for maintenance and

roll down. The area beyond the fence must be undisturbed or stabilized.

3. The type of silt fence specified for each location on the plan shall not exceed the maximum slope length and maximum fence length requirements shown in the following table:

		Slope Length/Fence Length (ft.)		
Slope	Steepness	Standard	Reinforced	Super
<2%	< 50:1	300/1500	N/A	N/A
2-10%	50:1 to 10:1	125/1000	250/2000	300/2500
10-20%	10:1 to 5:1	100/750	150/1000	200/1000
20-33%	5:1 to 3:1	60/500	80/750	100/1000
33-50%	3:1 to 2:1	40/250	70/350	100/500
>50%	> 2:1	20/125	30/175	50/250

Standard Silt Fence (SF) is fabric rolls stapled to wooden stakes driven 16 inches in the ground.

Reinforced Silt Fence (RSF) is fabric placed against welded wire fabric with anchored steel posts driven 16 inches in the ground.

Super Silt Fence (SSF) is fabric placed against chain link fence as support backing with posts driven 3 feet in the ground.

4. Silt fence shall be removed as soon as the disturbed area has achieved final stabilization.

The silt fence shall be installed in accordance with the appropriate details. Where ends of filter cloth come together, they shall be overlapped, folded and stapled to prevent sediment bypass. Butt joints are not acceptable. A detail of the silt fence shall be shown on the plan. See Figure 5.30 on page 5.56 for Reinforced Silt Fence as an example of details to be provided.

Criteria for Silt Fence Materials

1. Silt Fence Fabric: The fabric shall meet the following specifications unless otherwise approved by the appropriate erosion and sediment control plan approval authority. Such approval shall not constitute statewide acceptance.

Fabric Properties	Minimum Acceptable Value	Test Method
Grab Tensile Strength (lbs)	110	ASTM D 4632
Elongation at Failure (%)	20	ASTM D 4632
Mullen Burst Strength (PSI)	300	ASTM D 3786
Puncture Strength (lbs)	60	ASTM D 4833
Minimum Trapezoidal Tear Strength (lbs)	50	ASTM D 4533
Flow Through Rate (gal/min/sf)	25	ASTM D 4491
Equivalent Opening Size	40-80	US Std Sieve ASTM D 4751
Minimum UV Residual (%)	70	ASTM D 4355

Super Silt Fence



2. Fence Posts (for fabricated units): The length shall be a minimum of 36 inches long. Wood posts will be of sound quality hardwood with a minimum cross sectional area of 3.5 square inches. Steel posts will be standard T and U section weighing not less than 1.00 pound per linear foot. Posts for super silt fence shall be standard chain link fence posts.
3. Wire Fence for reinforced silt fence: Wire fencing shall be a minimum 14 gage with a maximum 6 in. mesh opening, or as approved.
4. Prefabricated silt fence is acceptable as long as all material specifications are met.

Reinforced Silt Fence



**Figure 5.30
Reinforced Silt Fence**

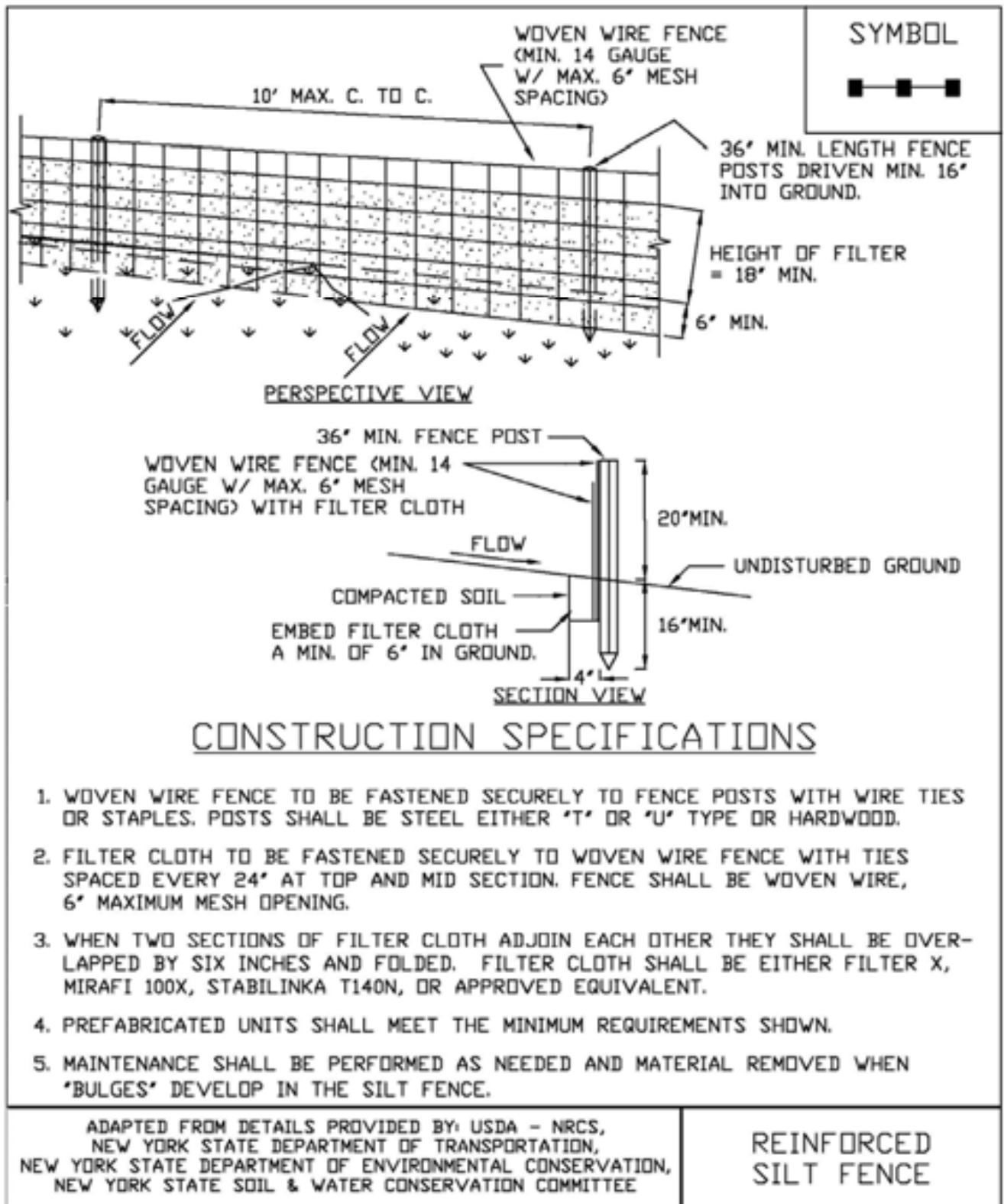

STANDARD AND SPECIFICATIONS FOR STRAW BALE DIKE



quarter of an acre per 100 feet of dike and the length of slope above the dike shall be less than 100 feet.

Design Criteria

The above table is adequate, in general, for a one-inch rain-fall event. Larger storms could cause failure of this practice. Use of this practice in sensitive areas for longer than one month should be specifically designed to store expected runoff. All bales shall be placed on the contour with cut edge of bale adhering to the ground. See Figure 5.34 on page 5.64 for details.

Definition & Scope

A **temporary** barrier of straw, or similar material, used to intercept sediment laden runoff from small drainage areas of disturbed soil to reduce runoff velocity and effect deposition of the transported sediment load. Straw bale dikes have an estimated design life of three (3) months.

Condition Where Practice Applies

The straw bale dike is used where:

1. No other practice is feasible.
2. There is no concentration of water in a channel or other drainage way above the barrier.
3. Erosion would occur in the form of sheet erosion.
4. Length of slope above the straw bale dike does not exceed the following limits with the bale placed 10 feet from the toe of the slope:

Constructed Slope	Percent Slope	Slope Length (ft.)
2:1	50	25
3:1	33	50
4:1	25	75

Where slope gradient changes through the drainage area, steepness refers to the steepest slope section contributing to the straw bale dike.

The practice may also be used for a single family lot if the slope is less than 15 percent. The contributing drainage areas in this instance shall be less than one

Figure 5.34
Straw Bale Dike

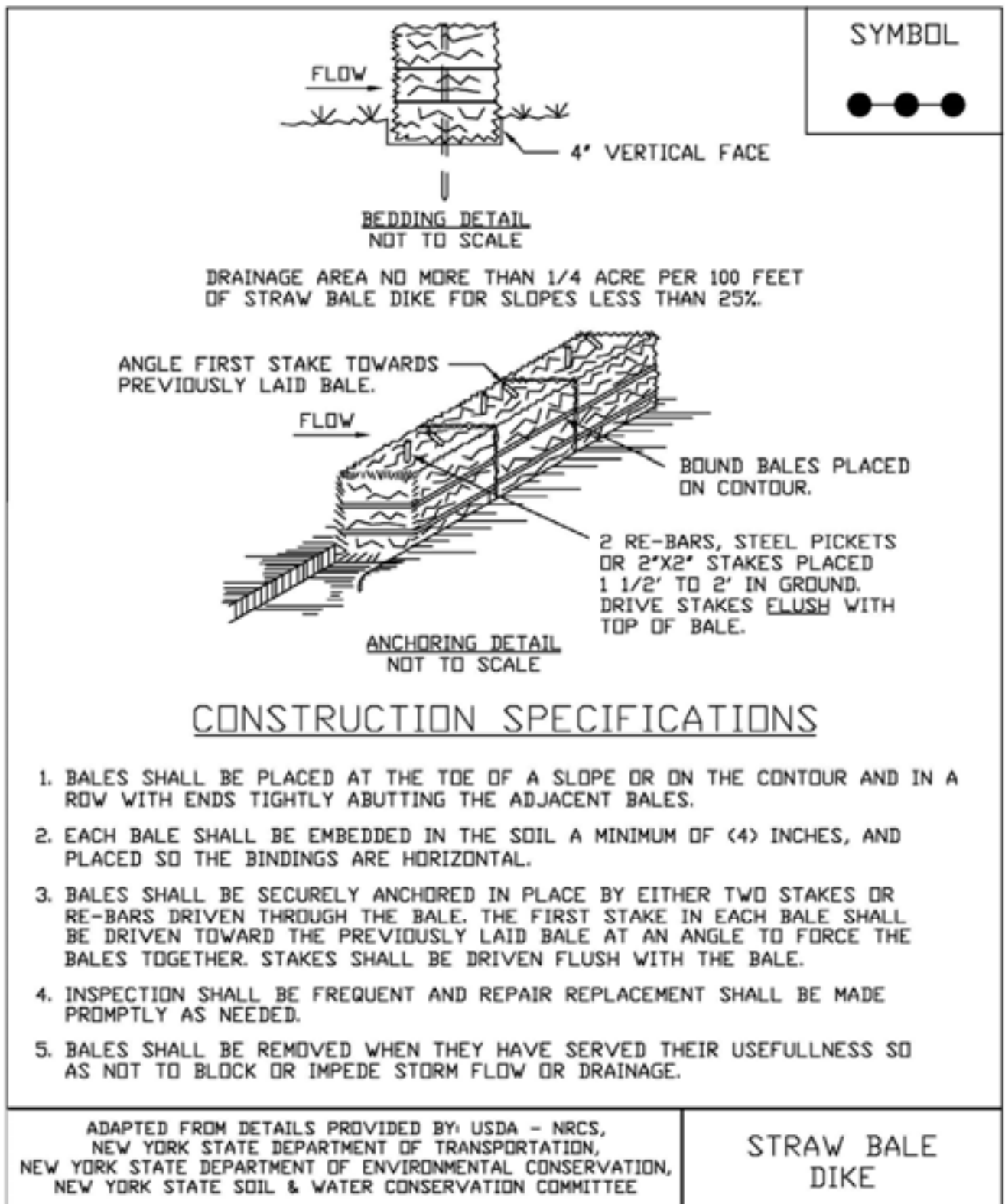

Appendix H – Spill Cleanup and Reporting Guidance

- NYSDEC Technical Field Guidance: Spill Reporting and Initial Notification Requirements -
- NYSDEC CP-51: Soil Cleanup Guidance -

**Appendix H – NYSDEC Technical Field Guidance: Spill Reporting and
Initial Notification Requirements**

TECHNICAL
FIELD GUIDANCE

**SPILL REPORTING AND INITIAL
NOTIFICATION REQUIREMENTS**

NOTES

Spill Reporting and Initial Notification Requirements

GUIDANCE SUMMARY AT-A-GLANCE

- Reporting spills is a crucial first step in the response process.
- You should understand the spill reporting requirements to be able to inform the spillers of their responsibilities.
- Several different state, local, and federal laws and regulations require spillers to report petroleum and hazardous materials spills.
- The state and federal reporting requirements are summarized in Exhibit 1.1-1.
- Petroleum spills must be reported to DEC unless they meet all of the following criteria:
 - The spill is known to be less than 5 gallons; and
 - The spill is contained and under the control of the spiller; and
 - The spill has not and will not reach the State's water or any land; and
 - The spill is cleaned up within 2 hours of discovery.

All reportable petroleum spills and most hazardous materials spills must be reported to DEC hotline (1-800-457-7362) within New York State; and (1-518 457-7362) from outside New York State. For spills not deemed reportable, it is strongly recommended that the facts concerning the incident be documented by the spiller and a record maintained for one year.

- Inform the spiller to report the spill to other federal or local authorities, if required.
- Report yourself those spills for which you are unable to locate the responsible spiller.
- Make note of other agencies' emergency response telephone numbers in case you require their on-scene assistance, or if the response is their responsibility and not BSPR's.

NOTES

1.1.1 Notification Requirements for Oil Spills and Hazardous Material Spills

Spillers are required under state law and under certain local and federal laws to report spills. These various requirements, summarized in Exhibit 1.1-1, often overlap; that is, a particular spill might be required to be reported under several laws or regulations and to several authorities. Under state law, all petroleum and most hazardous material spills must be reported to DEC Hotline (1-800-457-7362), within New York State, and to 1-518-457-7362 from outside New York State. Prompt reporting by spillers allows for a quick response, which may reduce the likelihood of any adverse impact to human health and the environment. You will often have to inform spillers of their responsibilities.

Although the spiller is responsible for reporting spills, other persons with knowledge of a spill, leak, or discharge is required to report the incident (see Appendices A and B). You will often have to inform spillers of their responsibilities. You may also have to report spills yourself in situations where the spiller is not known or cannot be located. However, it is the legal responsibility of the spiller to report spills to both state and other authorities.

BSPR personnel also are responsible for notifying other response agencies when the expertise or assistance of other agencies is needed. For example, the local fire department should be notified of spills that pose a potential explosion and/or fire hazard. If such a hazard is detected and the fire department has not been notified, call for their assistance immediately. Fire departments are trained and equipped to respond to these situations; you should not proceed with your response until the fire/safety hazard is eliminated. For more information on interagency coordination in emergency situations see Part 1, Section 3, Emergency Response.

Another important responsibility is notifying health department officials when a drinking water supply is found to be contaminated as a result of a spill. It will be the health department's responsibility to advise you on the health risk associated with any contamination.

Exhibits 1.1-1 and 1.1-2 list the state and federal requirements to report petroleum and hazardous substance spills, respectively. The charts describe the type of material covered, the applicable act or regulation, the agency that must be notified, what must be reported, and the person responsible for reporting. New York state also has a emergency notification network for spill situations (e.g., major chemical releases) that escalate beyond the capabilities of local and regional response agencies/authorities to provide adequate response. The New York State Emergency Management Office (SEMO) coordinates emergency response activities among local, state, and federal government organizations in these cases.

Exhibit 1.1-1

State and Federal Reporting Requirements for Petroleum Spills, Leaks, and Discharges

Materials Covered	Act or Regulation	Agency to Notify	What Must Be Reported and When	Who Must Report
Petroleum from any source	Navigation Law Article 12; 17 NYCRR 32.3 and 32.4	DEC Hotline 1-800-457-7362	<p>The notification of a discharge must be immediate, but in no case later than two hours after discharge.</p> <ol style="list-style-type: none"> 1. Name of person making report and his relationship to any person which might be responsible for causing the discharge. 2. Time and date of discharge. 3. Probable source of discharge. 4. The location of the discharge, both geographic and with respect to bodies of water. 5. Type of petroleum discharges. 6. Possible health or fire hazards resulting from the discharge. 7. Amount of petroleum discharged. 8. All actions that are being taken to clean up and remove the discharge. 9. The personnel presently on the scene. 10. Other government agencies that have been or will be notified. 	Any person causing discharge of petroleum. Owner or person in actual or constructive control must notify DEC unless that person has adequate assurance that such notice has already been given.
All aboveground petroleum and underground storage facilities with a combined storage capacity of over 1100 gallons.	ECL §17-1007; 6 NYCRR §613.8	DEC Hotline 1-800-457-7362	<ol style="list-style-type: none"> 1. Report spill incident within two hours of discovery. 2. Also when results of any inventory, record, test, or inspection shows a facility is leaking, that fact must be reported within two hours of discovery. 	Any person with knowledge of a spill, leak, or discharge.
Petroleum contaminated with PCB.	Chemical Bulk Storage Act 6 NYCRR Parts 595, 596, 597	DEC Hotline 1-800-457-7362	Releases of a reportable quantity of PCB oil.	Owner or person in actual or constructive possession or control of the substance, or a person in contractual relationship, who inspects, tests, or repairs for owner.

Exhibit 1.1-1

**State and Federal Reporting Requirements for Petroleum Spills, Leaks, and Discharges
(continued)**

Materials Covered	Act or Regulation	Agency to Notify	What Must Be Reported and When	Who Must Report
Any liquid (petroleum included) that if released would be likely to pollute lands or waters of the state.	ECL §17-1743	DEC Hotline 1-800-457-7362	Immediate notification that a spill, release, or discharge of any amount has occurred. Owner or person in actual or constructive possession or control of more than 1,100 gallons of the liquid.	
Petroleum Discharge in violation of §311(b)(3) of the Clean Water Act	40 CFR §110.10 (Clean Water Act)	<ol style="list-style-type: none"> 1. National Response Center (NRC) 1-800-424-8802. 2. If not possible to notify NRC, notify Coast Guard or predesignated on-scene coordinator. 3. If not possible to notify either 1 or 2, reports may be made immediately to nearest Coast Guard units, provided NRC notified as soon as possible. 	<p>Immediate notification as soon as there is knowledge of an oil discharge that violates water quality standards or causes sheen on navigable waters.</p> <p>Procedures for notice are set forth in 33 CFR Part 153, Subpart B, and in the National Oil and Hazardous Substances Pollution Contingency Plan, 40 CFR Part 300, Subpart E.</p>	Person in charge of vessel or on-shore or off-shore facility.
Petroleum, petroleum by-products or other dangerous liquid commodities that may create a hazardous or toxic condition spilled into navigable waters.	33 CFR 126.29 (Ports and Waters Safety Act)	Captain of the Port or District Commander	As soon as discharge occurs, owner or master of vessel must immediately report that a discharge has occurred.	Owner or master of vessel or owner or operator of the facility at which the discharge occurred.

Exhibit 1.1-1

**State and Federal Reporting Requirements for Petroleum Spills, Leaks, and Discharges
(continued)**

Materials Covered	Act or Regulation	Agency to Notify	What Must Be Reported and When	Who Must Report
Petroleum or hazardous substance from a vessel, on-shore or off-shore facility in violation of §311(b)(3) of the Clean Water Act.	33 CFR 153.203 (Clean Water Act)	<ol style="list-style-type: none"> 1. NRC U.S. Coast Guard, 2100 Second Street, SW, Washington, DC 20593; 1-800-424-8802. 2. Where direct reporting not practicable, reports may be made to the Coast Guard (District Offices), the 3rd and 9th district of the EPA regional office at 26 Federal Plaza, NY, NY 10278; 1-201-548-8730. 3. Where none of the above is possible, may contact nearest Coast Guard unit, provided NRC notified as soon as possible. 	Any discharger shall immediately notify the NRC of such discharge.	Person in charge of vessel or facility.

Exhibit 1.1-2

State and Federal Reporting Requirements for Hazardous Substance Spills, Leaks, and Discharges

Materials Covered	Act or Regulation	Agency to Notify	What Must Be Reported and When	Who Must Report
Any hazardous substance pursuant to Article 37. Does not include petroleum.	Chemical Bulk Storage Act 6 NYCRR Parts 595, 596, 597; ECL 40-0113(d)	DEC Hotline 1-800-457-7362	Releases of a reportable quantity of a hazardous substance.	Owner or person in actual or constructive possession or control of the substance, or a person in contractual relationship, who inspects, tests, or repairs for owner.
Hazardous materials or substances as defined in 49 CFR §171.8 that are transported. (See federal reporting requirements.)	Transportation Law 14(f); 17 NYCRR 507.4(b)	Local fire department or police department or local municipality	<p>Immediate notification must be given of incident in which any of the following occurs as a direct result of a spill of hazardous materials:</p> <ol style="list-style-type: none"> 1. Person is killed. 2. Person receives injuries requiring hospitalization. 3. Estimated damage to carrier or other property exceeds \$50,000. 4. Fire, breakage, spillage, or suspected contamination due to radioactive materials. 5. Fire, breakage, spillage, or suspected contamination involving etiologic agents. 6. Situation is such that, in the judgment of the carrier, a continuing danger to life or property exists at the scene of the incident. 	All persons and carriers engaged in the transportation of hazardous materials.

Exhibit 1.1-2
State and Federal Reporting Requirements for Hazardous Substance Spills, Leaks, and Discharges
(continued)

Materials Covered	Act or Regulation	Agency to Notify	What Must Be Reported and When	Who Must Report
Hazardous materials (wastes included) that are transported, whose carrier is involved in an accident.	Department of Transportation Regulations 49 CFR 171.15; 17 NYCRR Part 924; 17 NYCRR Part 507	<ol style="list-style-type: none"> 1. U.S. Department of Transportation 1-800-424-8802 2. DEC Hotline 1-800-457-7362 3. Rail Carrier <u>On-Duty</u> 518-457-1046 <u>Off-Duty</u> 518-457-6164 4. Notify local police or fire department. 	<p>Notice should be given by telephone at the earliest practicable moment and should include:</p> <ol style="list-style-type: none"> 1. Name of reporter. 2. Name and address of carrier represented by reporter. 3. Phone number where reporter can be contacted. 4. Date, time, and location of incident. 5. The extent of injuries, if any. 6. Classification, name and quantity of hazardous materials involved, if available. 7. Type of incident and nature of hazardous material involved and whether a continuing danger to life exists at scene. 8. Each carrier making this report must also make the report required by §171.16. 	<p>Each carrier that transports hazardous materials involves in an accident that causes any of the following as a direct result:</p> <ol style="list-style-type: none"> 1. A person is killed 2. A person receives injuries requiring hospitalization 3. Estimated damage to carrier or other property exceeds \$50,000 4. Fire, breakage, spillage, suspected or otherwise involving radioactive material. 5. Fire, breakage, spillage, suspected contamination involving etiologic agents. 6. Situation is such that carrier thinks it should be reported in accordance with paragraph b.

Exhibit 1.1-2
State and Federal Reporting Requirements for Hazardous Substance Spills, Leaks, and Discharges
(continued)

Materials Covered	Act or Regulation	Agency to Notify	What Must Be Reported and When	Who Must Report
Reportable quantity of a hazardous substance into navigable waters or adjoining shorelines. Substances are listed in 40 CFR 302.4.	Department of Transportation Regulations 49 CFR §171.16 as authorized by the Hazardous Materials Transportation Act	U.S. Coast Guard National Response Center (NRC), 1-800-424-8802 or 1-202-267-2675	<p>As soon as person in charge becomes aware of a spill incident, he must notify NRC and provide the following information:</p> <ol style="list-style-type: none"> 1. The information required by 49 CFR §171.15 (see above). 2. Name of shipper of hazardous substance. 3. Quantity of hazardous substance discharged, if known. 4. If person in charge is incapacitated, carrier shall make the notification. 5. Estimate of quantity of hazardous substance removed from the scene and the manner of disposition of any unremoved hazardous substance shall be entered in Part (H) of the report required by 49 CFR 171.16 (see above). 	Person in charge of aircraft, vessel, transport vehicle, or facility. Must inform NRC directly, or indirectly through carrier.
Reportable quantity of a hazardous substance from vessel, on-shore or off-shore facility. Substances and requirements specified in 40 CFR §117.3.	40 CFR §117.21 as authorized under the FWPCA	NRC 1-800-424-8802. If not practicable report may be made to the Coast Guard (3rd or 9th Districts) District Offices or to EPA, designated On-Scene Coordinator, Region II, 26 Federal Plaza, NY, NY 10278; 1-201-548-8730	Immediate notification is required.	Person in charge of vessel, or on-shore or off-shore facility

**Exhibit 1.1-2
State and Federal Reporting Requirements for Hazardous Substance Spills, Leaks, and Discharges
(continued)**

Materials Covered	Act or Regulation	Agency to Notify	What Must Be Reported and When	Who Must Report
<p>Facilities where a hazardous chemical is produced, used, or stored, and there is a reportable quantity of any extremely hazardous substance as set out in Appendix A to 40 CFR 355 or a CERCLA hazardous substance as specified in 40 CFR 302.4. (This section does not apply to a release that does not go beyond the facility, that emanates from a facility that is federally permitted, is continuous as defined under §103(f) of CERCLA or to any release exempt from CERCLA §103(a) reporting under §101(22) of CERCLA.)</p>	<p>40 CFR 355.40 (SARA)</p> <p>Releases of CERCLA Hazardous Substances are subject to release reporting requirements of CERCLA §103, codified at 40 CFR Part 302, in addition to being subject to the requirements of this Part.</p>	<p>Community emergency coordinator for the local emergency planning committee of any area likely to be affected and the State Emergency Response Commission of any state likely to be affected by the release. If there is no local emergency planning commission notification shall be made to relevant local emergency response personnel.</p>	<p>Immediately notify agencies at left and provide the following information when available:</p> <ol style="list-style-type: none"> 1. Chemical name or identity of any substance involved in the release. 2. Indication of whether the substance is an extremely hazardous substance. 3. An estimate of the quantity released. 4. Time and duration of release. 5. Medium or media into which the release occurred. 6. Known health risks associated with emergency and where appropriate advice regarding medical attention for those exposed. 7. Proper precautions/actions that should be taken, including evacuation. 8. Names and telephone numbers of person to be contacted for further information. <p>As soon as practicable after release, followup notification by providing the following information:</p> <ol style="list-style-type: none"> 1. Actions taken to respond to and contain the release. 2. Health risks. 3. Advice on medical attention for exposed individuals. 	<p>Owner or operator of facility</p>

Exhibit 1.1-2
State and Federal Reporting Requirements for Hazardous Substance Spills, Leaks, and Discharges
(continued)

Materials Covered	Act or Regulation	Agency to Notify	What Must Be Reported and When	Who Must Report
Hazardous liquids transported in pipelines, a release of which results in any circumstances as set out in 195.50(a) through (f). Also any incident that results in circumstances listed in 195.52(g).	49 CFR 195.50, 195.52 and 195.54 (Hazardous Liquid Pipeline Safety Act).	NRC, 1-800-424-8802	<p>Notice must be given at the earliest practicable moment and the following information provided:</p> <ol style="list-style-type: none"> 1. Name and address of the operator. 2. Name and telephone number of the reporter. 3. Location of the failure. 4. The time of the failure. 5. The fatalities and personal injuries, if any. 6. All other significant facts known by the operator that are relevant to the cause of the failure or extent of the damages. 	Operator of system.
Hazardous wastes in transport	40 CFR §263.30(a) (RCRA)	<ol style="list-style-type: none"> 1. Local authorities 2. If required by 49 CFR 171.15, notify the NRC at 1-800-424-8802 or 1-202-426-2675 3. Report in writing to Director of Hazardous Materials Regulations, Materials Transportation Bureau, Department of Transportation, Washington, DC 20590 	<p>Notification must be immediate.</p> <p>For discharge of hazardous waste by air, rail, highway, or water, the transporter must:</p> <ol style="list-style-type: none"> 1. Give notice as in 49 CFR 161.15 (if applicable). 2. Report in writing as in 49 CFR 171.16. <p>Wastes transporter (bulk shipment) must give same notice as required by 33 CFR 153.20.</p>	Transporter by air, rail, highway, or water.

Exhibit 1.1-2
State and Federal Reporting Requirements for Hazardous Substance Spills, Leaks, and Discharges
(continued)

Materials Covered	Act or Regulation	Agency to Notify	What Must Be Reported and When	Who Must Report
Vinyl Chloride from any manual vent valve, or polyvinyl chloride plants	Clean Air Act 40 CFR 61.64	Administrator of EPA	<p>Within 10 days of any discharge from any manual vent valve, report must be made, in writing, and the following information provided:</p> <ol style="list-style-type: none"> 1. Source, nature and cause of the discharge 2. Date and time of the discharge 3. Approximate total vinyl chloride loss during discharge 4. Method used for determining loss 5. Action taken to prevent the discharge 6. Measures adopted to prevent future discharges. 	Owner or operator of plant.
Radioactive Materials	6 NYCRR §380.7	Commissioner of DEC	<ol style="list-style-type: none"> 1. Notify immediately by telephone when concentration, averaged over a 24-hour period, exceeds or threatens to exceed 5000 times the limits set forth in Schedule 2 of 380.9 (in uncontrolled areas). 2. Notify within 24 hours by telephone when concentration, averaged over 24- hour period, exceeds or threatens to exceed 500 times the limits set forth in Schedule 2 above (in uncontrolled areas). 3. Report within 30 days the concentration and quantity of radioactive material involved, the cause of the discharge, and corrective steps taken or planned to ensure no recurrence of the discharge. 	Operator of the radiation installation.

Exhibit 1.1-2
State and Federal Reporting Requirements for Hazardous Substance Spills, Leaks, and Discharges
(continued)

Materials Covered	Act or Regulation	Agency to Notify	What Must Be Reported and When	Who Must Report
Low Level radioactive wastes in transport. Any suspected or actual uncontrolled releases.	6 NYCRR 381.16 ECL §27-0305 Waste Transporter Permits	DEC and Department of Health	Immediate notification.	Transporter

TECHNICAL
FIELD GUIDANCE

**SPILL REPORTING AND INITIAL NOTIFICATION
ENFORCEMENT OF SPILLER RESPONSIBILITY**

NOTES

Spill Reporting and Initial Notification - Enforcement of Spiller Responsibility

GUIDANCE SUMMARY-AT-A-GLANCE

Use the "Notification Procedures Checklist" (Exhibit 1.1-3) to document conversations with the responsible party or potentially responsible party (PRP/RP) concerning his or her clean-up responsibilities.

The steps to follow when you inform the PRP/RP of his or her legal responsibility are:

- Give your name and identify yourself as a DEC employee;
- Inform them that they have been identified as the party responsible for the spill;
- Inform PRP/Rps of their liability for all clean-up and removal costs. (If necessary, cite Section 181 of the Navigation Law);
- Ask PRP/Rps "point blank" if they will accept responsibility for the cleanup; and
- If the PRP/RP does not accept responsibility, or does not admit to being the PRP/RP, inform him or her that DEC will conduct the cleanup and send the bill to whoever is the PRP/RP. Also inform them that a DEC-conducted cleanup could be more costly than a PRP/RP-conducted cleanup, and that the PRP/RP could face interest charges and penalties for refusing to clean up the spill.

If the PRP/RP accepts responsibility for the cleanup:

- (1) Send the PRP/RP a "Spiller Responsibility Letter" (Exhibit 1.1-5) and an "Acceptance of Financial Responsibility Form" (Exhibit 1.1-6) and
- (2) Send the PRP/RP an "Option Letter," which should outline the options available to the PRP/RP to clean up the spill. See Exhibit 1.1-4 for a summary of how and when to use these forms and what they may include.

NOTES

1.1.2 Spill Reporting and Initial Notification - Enforcement of Spiller Responsibility

This section provides guidance on those steps you take to inform responsible parties or potentially responsible parties (PRP/Rps) or spillers of their responsibility under state law for cleaning up spills. This guidance applies to all contacts (by phone, by mail, or in person) you have with Rps throughout the response process concerning their fulfillment of this legal responsibility. The possible consequences of an RP's refusal or inability to conduct the spill response are also discussed.

1. State Law and Policy

Under Article 12 of the Navigation Law and Article 71 of the Environmental Conservation law (ECL), those parties responsible for a petroleum release are liable for all costs associated with cleaning up the spill as well as third party damages (see Introduction-A for more information). Section 181 of the Navigation Law states:

Any person who has discharged petroleum shall be strictly liable, without regard to fault, for all cleanup and removal costs and all direct damages, no matter by whom sustained as defined in this section.

There are two ways by which PRP/RPs can pay for the costs associated with cleanups. First, the PRP/RP can reimburse the state for site investigation, clean-up, and remediation costs incurred by the State Oil Spill Fund or federal Leaking Underground Storage Tank (LUST) Trust Fund. Second, the PRP/RP can assume full responsibility for the cleanup from the beginning and bear all costs throughout the clean-up process. It is DEC's policy to make every effort to have PRP/RPs pay for cleanups from the outset.¹

To achieve PRP/RP-directed and PRP/RP-financed cleanups, your responsibilities are to: (1) identify the PRP/RP(s), (2) inform them of their legal responsibilities for the spill, and (3) ensure that they carry out these responsibilities. All investigations of spills and PRP/RPs should be pursued vigorously and without prejudice. Use to your advantage the argument that having the PRP/RP assume responsibility for clean-up costs benefits both DEC and the spiller. It saves DEC the expense of cost-recovery procedures. It also allows the PRP/RP to be more involved in clean-up decisions (e.g., choosing their clean-up contractors) and, more significantly, it usually results in **lower clean-up costs. Because the PRP/RP is responsible for all indirect costs incurred if DEC conducts the cleanup, the spiller will pay for the DEC contractor's clean-up work, as well as the supervision costs incurred by DEC, any third-party claims associated with the spill, and any punitive fines levied.**

¹ Spillers are not only responsible for assuming the costs of a cleanup, but also can be subject to a \$25,000 per day fine for not paying the clean-up costs (among other violations). The Navigation Law provides for these penalties in Section 192, which states:

Any person who knowingly gives or causes to be given any false information as a part of, or in response to, any claim made pursuant to this article for cleanup and removal costs, direct or indirect damages resulting from a discharge, or who otherwise violates any of the provisions of this article or any rule promulgated thereunder or who fails to comply with any duty created by this article shall be liable to a penalty of not more than twenty-five thousand dollars for each offense in court of competent jurisdiction. If the violation is of a continuing nature each day during which it continues shall constitute an additional, separate, and distinct offense. (emphasis added)

NOTES

2. Notification Process

Part 1, Section 4, of this manual discusses the process of identifying the PRP/RP as part of the spill investigation for a particular site. Once you identify the PRP/RP, follow the guidance provided below for informing the PRP/RP of his or her responsibilities for spill cleanup. If you are uncertain about who the PRP/RP is, apply the procedures outlined below with all suspected RPs until the responsible party or parties are identified.

a. Informing RPs of Their Responsibility at the Spill Scene

It is important to inform PRP/RPs of their legal responsibility to clean up a spill as soon as possible. When you arrive at a spill site, you should immediately inform the representative of any PRP/RP of their liability under the Navigation Law and the Environmental Conservation Law. In doing so, follow the steps covered in the "Notification Procedures Checklist" (Exhibit 1.1-3).

Document completion of the notification steps, and identify your contact(s).

Although you should be firm and direct in informing the PRP/RP of their responsibility, you should make every attempt to avoid an adversarial relationship with the RP. The full cooperation of the PRP/RP will result in a more efficient and effective cleanup.

b. Informing Spillers of Their Responsibility in Writing

You should send three different letters to the PRP/RP to inform them of their responsibility (see Exhibit 1.1-4, "Notification Forms Summary"). If a site response was initiated and you are able to confirm the spill visually, the "Spiller Responsibility Letter" (Exhibit 1.1-5) along with an "Acceptance of Financial Responsibility Form" (Exhibit 1.1-6) should be sent as soon as possible. In addition, an "Option Letter" that informs the PRP/RP of their possible options for addressing a spill should be sent. These letters should be kept as part of the Corrective Action Plan (CAP) (see Part 1, Section 5, "Corrective Action Plans.")

**Exhibit 1.1-3
Notification Procedures Checklist**

Completed	Step	Date	Contact(s)
_____	1. Give your name and identify yourself as a DEC employee.		
_____	2. Inform the PRP/RP that he/she has been identified as the party responsible for the spill.		
_____	3. Inform PRP/RPs of their responsibility to pay for all clean-up costs. (As necessary, cite Section 181 of the Navigation Law or Article 71 of the ECL.)		
_____	4. Ask PRP/RPs "point blank" if they will accept responsibility for the cleanup.		
	Response: _____ _____ _____ _____		
_____	5. If the PRP/RP does not accept responsibility, or does not admit to being the spiller, inform him/her that DEC will conduct the cleanup and send the bill to whoever is the spiller.		
_____	6. If the PRP/RP does not accept responsibility also inform him or her that a DEC-conducted cleanup could be more costly than a spiller-conducted cleanup, and that the spiller could face interest charges and a fine for refusing to pay for the billed clean-up costs.		

Exhibit 1-A-4

**Notification Forms Summary
(Send Forms by Certified Mail)**

Notification Form	When and How to Use	Information to be Included
Spiller Responsibility Letter	Send by certified mail to PRP/RP for confirmed spill.	<ul style="list-style-type: none"># Spill location;# Spiller's responsibility under the Navigation Law;# Penalties that can be levied if the spiller does not cooperate; and# Deadline for spiller to begin containment and removal of the spill.
Acceptance of Spiller Responsibility Form	Send by certified mail to PRP/RP for confirmed spill.	<ul style="list-style-type: none"># Request for spiller's signature acknowledging his or her acceptance of responsibility for the spill cleanup.
Option Letter	Send by certified mail to PRP/RP for confirmed or suspected release (e.g., failed tightness test).	<ul style="list-style-type: none"># Spill number;# Date spill was discovered or reported;# Exact location of the spill;# Authority of Article 12 of the Navigation Act; and# Penalties for noncompliance.

Exhibit 1.1-5

Spiller Responsibility Letter

[Date]

[Addressee]

[Address]

Dear []:

This is to inform you that as a result of investigation by our Department, we consider you responsible for Petroleum Spill Number _____, dated _____, at _____. Under Article 12 of the Navigation Law, Section 192, any person who discharges petroleum without a permit and fails to promptly clean up such prohibited discharge may be subject to a penalty of up to \$25,000 a day.

Containment and removal of this spill must be initiated within _____ hours.

Your failure to initiate timely spill cleanup and removal, in addition to the penalty stated above, will result in your being billed for all actual costs incurred by New York State as set forth in Section 181 of the Navigation Law. These costs include cleanup and removal, all direct and indirect damages, including damages incurred by third parties.

Sincerely,

Regional Spill Engineer
Region

Exhibit 1.1-6
Acceptance of Spiller Responsibility Letter

[Date]

SPILL # _____

ACCEPTANCE OF FINANCIAL RESPONSIBILITY

_____, hereby assumes responsibility for containment and
(Name of Company and Person)

cleanup of _____ discharged from _____
(Substance) (Source)

on _____, and recognizes that the determination of the adequacy and propriety of
(Date)

the containment and cleanup operation continues to rest with the New York State
Department of Environmental Conservation On-Scene Coordinator.

(Authorized Signature and Title)

(Name and Title Printed)

(Address of Company)

(Date and Time)

(Witness)

NOTES

The "Spiller Responsibility Letter" informs spillers of their responsibility under the Navigation Law and explains the penalties that can be levied if the spiller does not cooperate. It should be sent to the spiller or suspected spiller as soon as a petroleum spill has been confirmed. The letter notifies the spiller that he or she is required to initiate containment and removal of the spill within a period of time you specify.

There are at least three factors you should consider when specifying a deadline in this letter:

- # The size and nature of the spill;
- # The proximity of the spill to, or its possible effects on, water supplies (surface or ground water), nearby homes and other structures, and/or sensitive environmental areas; and The possible environmental, safety, and/or human health effects of delaying containment and removal.

The "Acceptance of Spiller Responsibility Form" requires the spiller's signature acknowledging his or her responsibility for containment and cleanup of the spill. This form and the "Spiller Responsibility Letter" should be sent by certified mail.

The "Option Letter" outlines the possible options available to the PRP/RP for cleanup of the spill. The contents of this letter can vary somewhat depending on how the release was discovered (e.g., through a complaint or a failed tightness test), the extent and type of spill, and the policies and procedures of your regional office. There is, however, some information that should appear in every "Option Letter." All "Option Letters" should contain the following: spill number, date the spill was discovered, and exact location of the spill. In addition, the letter should cite the response authority provided DEC by Article 12 of the Navigation Act and describe the penalties for noncompliance.

Each "Option Letter" should outline clearly the options open to the PRP/RP to address the spill and the information you wish submitted, and may also specify certain deadlines for taking action. However, it is up to you to determine the particular options, information requirements, and dates you include in the letter. Depending on the circumstances, you may list in your letter one or several options from which the PRP/RP can choose. For example, when an UST fails an initial tank test the following options could be included:

- # Conduct separate integrity tests on the piping and the tanks in order to verify the release source within the tank system.
- # Remove the "non-tight" tank and either remove and dispose of all contaminated soils, or install monitoring wells.

NOTES

- # Install monitoring wells and abandon the "non-tight" tank in-place.
- # Remove the tank within 30 days, according to the requirements for tank removal (outline these requirements in the letter).

The "Option Letter" should always be sent by certified mail. In addition, you should have the PRP/RP inform you as soon as possible about the option(s) he or she has chosen.

Several examples of possible "Option Letters" are included as Exhibits 1.1-7 through 1.1-12. These are provided as examples only; you should use "Option Letters" developed by your own office, or develop your own.

Exhibit 1.1-7 is a sample option letter to an PRP/RP for removal of contaminated soil from an UST release. Note that this option letter includes: (a) specific requirements for removal of the contaminated soil; (b) dates for when the removal must be completed, and (c) requirements for the PRP/RP to forward to DEC copies of the landfill disposal receipt and ample test results. The additional sample option letters apply to the following situations: when an UST has failed an initial tightness test (Exhibit 1.1-8), when an UST fails an isolation tank test (Exhibit 1.1-9), when an UST fails a Petro-tite Systems Test (Exhibit 1.1-10), and ground-water contamination cleanup (Exhibit 1.1-11).

3. Dealing with Uncooperative Spillers

There are generally two ways in which an PRP/RP may fail to fulfill his or her legal responsibilities for spill cleanup: (1) a PRP/RP may refuse from the beginning to accept responsibility, or (2) an PRP/RP may fail to conduct a cleanup in the manner, or in as timely a fashion, as agreed upon with the DEC. If a PRP/RP refuses to cooperate from the outset, try again to change the RP's mind. Send additional notices of spiller responsibility (Exhibit 1.1-12) and/or initiate phone conversations with PRP/RPs to inform them again of the consequences of not cooperating (i.e., higher clean-up costs and possible penalties). If a party claims not to be the PRP/RP, you should inform them of your reasons for believing they are the PRP/RP under the Navigation Law.

If a PRP/RP agrees to conduct and pay for the cleanup and then does not proceed in the manner agreed upon or as quickly as agreed upon, you should inform the PRP/RP immediately that you are dissatisfied with the progress of the cleanup and that DEC is considering taking it over. There are no hard-and-fast rules for deciding when you should take over a cleanup. If possible, you should always work toward having the PRP/RP continue the cleanup in the agreed-upon manner. Attempt to determine why the cleanup is not proceeding as planned and consider means of helping the PRP/RP-directed cleanup get back on track.

Exhibit 1.1-7

Sample Option Letter:
Soil Cleanup Spill

[Date]

[Addressee]

[Address]

Dear []:

This letter is to confirm your - (site meeting) (telephone conversation) with _____ of this Department on _____, (Name) (day) (date) (year) in regards to the above-mentioned spill site. This site involves _____ (explanation)

The following items were discussed and agreed upon:

1. All contaminated material must be removed and stored on site until it can be properly disposed of at a properly permitted landfill.
2. All contaminated material must be sampled for _____ (analyses). The results must be negative for the material to be considered non-hazardous oily debris. You must contact your selected sanitary landfill to verify the sample analyses that they require for disposal.
3. A hauler with a Part 364 permit must be used to haul the contaminated soil to your selected landfill.
4. Please notify this Department after the work is completed but prior to any backfilling of the spill area so that an inspection of the excavation may be made.
5. Please forward to us a copy of the landfill disposal receipt and the sample results.

A schedule for this work is required by _____ (day) (date) (year).

Cleanup must be performed by no later than _____ (day) (date) (year).

If you have any questions, please feel free to contact _____ (Name)

at 847-4590. Your cooperation will be appreciated.

Very truly yours,

Senior Sanitary Engineer

Exhibit 1.1-8

Sample Option Letter:
Initial Tank Failure

[Date]

[Addressee]

[Address]

Dear []:

This Department received notification on _____ that (a)
_____ (day) (date) (year)
_____ tank(s) failed its (their) tank test performed by
(gallons) (product stored)
_____. On _____, Mr. _____ of this Department
(contractor) (date) (name)
discussed with _____ that one of the following options must be done concerning this tank.
(person)

- OPTION 1:
1. The tank is to be immediately isolated from the piping and is to be retested. If the tank tests tight, it may remain in service.
 2. The lines are to be repaired, if necessary, and retested by a state-approved method. Exposed piping may be air tested.
 3. A copy of any test results are to be sent to this office.

- OPTION 2: If the tank fails the retest, or if you decide not to retest, the following must now be done:
1. All product must be immediately removed from the tank.
 2. The tank itself must be removed within thirty days. A Petroleum Bulk Storage form must be submitted to this Department prior to tank removal.
 3. The interior surface of the tank must be cleaned, and all sludge and residue generated by this process must be properly disposed. The tank must be cut open to allow for this work and to ensure proper ventilation of the tank interior.
 4. All safety precautions regarding the opening, cleaning and entering of the tank must be followed. The interior atmosphere of the tank may be explosive and proper procedures must be followed.
 5. Once the tank has been cleaned out, it may be disposed as scrap.

Mr. _____ must be notified when you have a firm date for retesting or removal. Please note, we must be present when this tank is removed to determine if any groundwater or soil contamination exists. If groundwater or soil contamination is found, further remedial work will be required.

If you have any questions, please contact _____ at 847-4590. Your cooperation will be appreciated.

Sincerely,

[]

Exhibit 1.1-9

Sample Option Letter:
Retest Failure, Tank Removal

[Date]

[Addressee]

[Address]

Dear []:

On _____, a _____ gallon _____, underground store storage tank at the
(day) (date) (year) (#) (material)
above-mentioned address failed a system tank test. On _____, this tank failed an isolation tank test.
(day) (date) (year)

Since the tank failed the retest, the following must now be done:

1. All product must be immediately removed from the tank.
2. The tank itself must be removed within thirty days. A Petroleum Bulk Storage form (enclosed) must be submitted to this Department prior to tank removal.
3. The interior surface of the tank must be cleaned, and all sludge and residue generated by this process must be properly disposed. The tank must be cut open to allow for this work and to ensure proper ventilation of the tank interior.
4. All safety precautions regarding the opening, cleaning and entering of the tank must be followed. The interior atmosphere of the tank may be explosive and proper procedures must be followed.
5. Once the tank has been cleaned out, it may be disposed as scrap.

_____ of this Department must be notified when you have a firm
(Name)

date for removal. We must be present when this tank is removed to determine if any groundwater or soil contamination exists. If groundwater or soil contamination is found, further remedial work will be required.

For your use, enclosed is a list of contractors that are known by this Department to do this type of work. This list is by no means complete. Any contractor may be used by you for this work.

If you have any questions, please feel free to call _____ at 847-4590.
(Name)

Your cooperation will be appreciated.

Sincerely,

[]

Exhibit 1.1-10

Sample Option Letter:
Failed Tank Test

[Date]

CERTIFIED - RETURN RECEIPT REQUESTED

[Addressee]

[Address]

RE: Spill No.

Gentlemen:

This office has been informed by _____ (Name) that _____ (tank) failed a Petrotite systems test. In accordance with Article 12 of the New York State Navigation Law, I must determine if there has been any harm to the lands or the groundwater of the State. In order for me to make this determination, you have three options:

1. Prove that it was not a leaking tank by removing all the piping from the tank and separately Petrotite test the tank. If the tank passes the Petrotite test, it is a piping leak. The tank may then be abandoned or the piping can be repaired, attached to the tank, and the system Petrotite tested.
2. Excavate and remove the tank in the presence of a representative from this office so that an inspection of the tank and the soil can be made. If the tank is sound, and there is no evidence of product loss, nothing further need be done. If there is a problem, proceed as in 3 below.
3. Abandon the tank in-place and install several four (4) inch diameter PVC site wells extending five (5) feet into the groundwater with a screen length of ten (10) feet, with slot size of .020 inches. The exact location and number of wells will be determined by a representative from this office. These wells will be checked for a period of twelve months by New York State, and if there is no evidence of product for that period, the spill will be removed from our listing. If free or dissolved product appears, cleanup must begin immediately.

If cleanup does not begin by _____ (Date) by the responsible party, the State will begin the cleanup and bill the responsible party.

Sincerely,

[]

Exhibit 1.1-11

Sample Option Letter:
Ground-water Cleanup

[Date]

[Addressee]

[Address]

Dear []:

This letter is to confirm your (site meeting) (telephone conversation) with (Name) of this Department on (day) (date) (year). Groundwater at this spill site is contaminated with (free floating oil) (dissolved oil components). The following items were discussed and agreed upon:

1. (#) additional four-inch monitoring wells will be installed at the agreed upon locations. A sketch of a typical monitoring well is enclosed for your use.
2. One recovery well will be installed to recover oil product. Groundwater must be pumped to depress the groundwater table. The groundwater must be pumped to an oil-water separator tank. Accumulated oil may be recovered from the well by bailing or by a second pump. A second type of recovery well pumps both oil and water to a separator tank. Oil from the tank is then recovered. You should check with your contractor to determine the best method for the recovery well. Groundwater must be pumped to depress the groundwater table.
3. The discharge water must be sampled for (Contaminates). Dependent upon the sampling results, it may be discharged with a SPDES permit to (Name). The water must at all times be sheenless. An air stripper or a carbon filter may be necessary for the discharge water.
4. All collected oil must be properly disposed. Copies of receipts indicating the disposal site must be forwarded to this office.

It was also agreed that these actions be completed by (Date). Should you have any questions, please do not hesitate to contact (Name) at 847-4590. Your cooperation will be appreciated.

Sincerely,

[]

Exhibit 1.1-12

Sample Option Letter:
Soil Disposal, Soil Still On Site

[Date]

[Addressee]

[Address]

Dear []:

A recent inspection by (Name) of this office indicated that the contaminated soil at your facility still remains on site. We are requesting this oil be removed by (day) (date) (year) to an acceptable landfill. Please send a copy of the disposal receipt to this office.

If you cannot remove the soil by that date, please contact this office immediately. If you do not contact this office and the soil still remains on site past (Date) , DEC will have the soil removed from your site. You will then be billed for the costs of removal and disposal as well any relevant penalties.

If you have any questions, please feel free to contact (Name) at 847-4590. Your cooperation will be appreciated.

Very truly yours,

Senior Sanitary Engineer

NOTES

If all efforts to encourage a PRP/RP to continue the cleanup fail, send a certified letter (Exhibit 1.1-13) notifying them that their actions have been unsatisfactory and that DEC will assume responsibility for the cleanup. This letter again informs the PRP/RP of his or her liability for all costs incurred by DEC during its cleanup.

Exhibit 1.1-13

Unsatisfactory Cleanup Notice Letter

[Date]

CERTIFIED MAIL

SPILL #

[Addressee]

[Address]

Dear Sir:

My letter of (Date) notified you of New York State's interest in a pollution incident for which you are presently considered responsible.

You are hereby given notice that your actions to remove the pollutant and mitigate its effects have been evaluated as unsatisfactory. Effective (Date), the New York State Department of Environmental Conservation will conduct all cleanup activities under the authority of Article 12 of the Navigation Law. Removal will be effected in accordance with the regulations of the Department of Environmental Conservation. You will be billed for all actual costs incurred by New York State as set forth in Section 181 of the Navigation Law, as well as interest and penalties.

Should you require further information concerning this matter, contact: (Name)

Sincerely,

[]

Received and Acknowledged

Time

Date

**TECHNICAL
FIELD GUIDANCE**

**SPILL REPORTING AND INITIAL NOTIFICATIONS -
ACCESS AND RIGHT-OF-ENTRY**

NOTES

Spill Reporting and Initial Notifications - Access and Right-of-Entry

GUIDANCE SUMMARY AT-A-GLANCE

- # Section 178 of the Navigation Law gives you the authority to enter private property to investigate or clean up a suspected spill.

- # In general, you should inform the property owner of your right to enter onto private property and obtain consent from the owner. This consent can be either written or verbal.

- # Detailed information and procedures for access and right-of-entry is considered confidential for spill responders. This information is contained in Appendix L, and is marked confidential.

NOTES

1.1.3 Access and Right-of-Entry

This section addresses the right of NYSDEC personnel to enter private property on which a spill has occurred or is suspected, for the purpose of investigating, containing, and/or cleaning up the spill. Detailed information and procedures of access and right-of-entry are considered confidential. Therefore, this information can be found in Appendix L, including your legal rights to enter property and the procedures to follow to ensure that no charges of trespassing are brought against the Department.

1. State Law and Policy

You have the authority, under the Navigation Law, to enter property to investigate or clean up a real or suspected spill. Specifically, Section 178 of the Navigation Law states:

The department is hereby authorized to enter and inspect any property or premises for the purpose of inspecting facilities and investigating either actual or suspected sources of discharges or violation of this article or any rule or regulations promulgated pursuant to this article. The department is further authorized to enter on property or premises in order to assist in the cleanup or removal of the discharge. Any information relating to secret processes or methods of manufacture shall be kept confidential.

In any emergency or non-emergency, you must possess information supporting a reasonable belief to suspect that a spill has occurred or is occurring, or that the spill is impacting the premises for which access is sought. A reasonable belief may be based on a report of a spill or visual observation. For example, if a gasoline station operator reports an unexpected loss of product from his underground storage tanks that are located near private household wells, you might want to investigate those wells and check the water.

Although you have the authority to enter the premises, *it is always advisable to obtain the consent of the property owner or his or her agent before entering the property.* This consent can be either written or verbal. Obtaining this consent may help avoid civil or criminal charges for trespass being logged. In cases where the owner/agent is not available or not ascertainable, entry should be made.

Appendix H – NYSDEC CP-51: Soil Cleanup Guidance

CP-51 / Soil Cleanup Guidance

New York State Department of Environmental Conservation

DEC Policy

Issuing Authority: Alexander B. Grannis, Commissioner

Date Issued: October 21, 2010

Latest Date Revised:

I. Summary

This policy provides the framework and procedures for the selection of soil cleanup levels appropriate for each of the remedial programs in the New York State Department of Environmental Conservation (DEC) Division of Environmental Remediation (DER). This policy applies to the Inactive Hazardous Waste Disposal Site Remedial Program, known as the State Superfund Program (SSF); Brownfield Cleanup Program (BCP); Voluntary Cleanup Program (VCP); Environmental Restoration Program (ERP); Spill Response Program - Navigation Law (NL) section 176 (SRP); and the Resource Conservation and Recovery Act (RCRA) Corrective Action Program. It replaces *Technical and Administrative Guidance Memorandum (TAGM) 4046: Determination of Soil Cleanup Objectives and Cleanup Levels* (January 24, 1994); the *Petroleum Site Inactivation and Closure Memorandum* (February 23, 1998); and Sections III and IV of *Spill Technology and Remediation Series (STARS) #1* (August 1992).

This document is used in conjunction with the applicable statutes, regulations and guidance. Site-specific soil cleanup levels, determined in accordance with this guidance, are only applied after:

- the site, or area of concern, is fully investigated to determine the nature and extent of contamination;
- all sources of contamination are addressed consistent with the hierarchy provided in 6 NYCRR 375-1.8(c) or consistent with the RCRA Corrective Action Program (as appropriate);
- groundwater, if contaminated, has been evaluated for appropriate remedial actions consistent with 6 NYCRR 375-1.8(d) or consistent with the RCRA Corrective Action Program (as appropriate); and
- impacts on adjacent residential properties, surface water, aquatic ecological resources are evaluated, as well as indoor air, soil vapor, vapor intrusion and other appropriate media.

II. Policy

It is DEC's policy, consistent with applicable statutes and regulations, that all remedies will be protective of public health and the environment. DEC's preference is that remedial programs, including the selection of soil cleanup levels, be designed such that the performance standard results in the implementation of a permanent remedy resulting in no future land use restrictions. However, some of

DEC's remedial programs are predicated on future site use. Further, it is not always feasible to return to a condition where no restrictions are required.

The procedures set forth herein are intended for the use and guidance of both DEC and remedial parties to provide a uniform and consistent process for the determination of soil cleanup levels. This guidance is not intended to create any substantive or procedural rights, enforceable by any party in administrative or judicial litigation with DEC. DEC reserves the right to act at variance with these procedures to address site-specific circumstances and to change the procedures in this guidance at any time.

Please note that this guidance focuses only on soil cleanup levels. All remedies must be fully protective of public health and the environment and must prevent further off-site migration to the extent feasible, with special emphasis on preventing or minimizing migration onto adjacent residential properties. A remedial party is required to evaluate and investigate, if necessary, all environmental media including soil, groundwater, surface water, sediments, soil vapor, ambient air, and biota. [See 6 NYCRR 375-1.8(a)(6) or RCRA Corrective Action Program (as appropriate)]. This investigation will determine if any of the referenced media are, or may be, impacted by site contamination. Applicable guidance should be consulted for media other than soil.

Nothing contained in this guidance, in itself, forms the basis for changes to previously selected remedies. However, a change in the site remedy may be considered consistent with *DER-2: Making Changes to Selected Remedies* (April 1, 2008). [See Section VI, Related References.] To the extent that a change to a selected remedy at a site in one of DER's remedial programs is necessary as provided in DER-2, as applicable, the Soil Cleanup Objectives (SCOs) may be considered in the evaluation of appropriate changes to the selected remedy. For sites in other programs, applicable regulations and guidance must be used.

III. Purpose and Background

DEC has a number of different remedial programs that were developed over time based on separate and distinct authorities. These programs use different procedures to determine the extent of soil cleanup necessary to satisfy the remedial program goals. The purpose of this document is to set forth how soil cleanup levels are selected for the different programs.

Legislation establishing New York State's Brownfield Cleanup Program (Article 27, Title 14 of the Environmental Conservation Law [ECL]) required DEC, in consultation with the New York State Department of Health (NYSDOH), to develop an approach for the remediation of contamination at brownfield sites. The resulting regulation includes seven sets of SCOs. Four sets provide for the protection of public health for different land uses (residential, restricted residential, commercial, and industrial); two sets provide for the protection of other resources (groundwater and ecological resources); and one set includes SCOs for protection of public health and the environment for all uses (unrestricted use).

With the promulgation of the SCOs, it is necessary to discuss how the SCOs, and soil cleanup levels generally, are arrived at for a specific site. Some key definitions in understanding how cleanup levels for soil are arrived at follow.

Feasible, which means suitable to site conditions, capable of being successfully carried out with available technology, implementable and cost effective [see 6 NYCRR 375-1.2(s)].

Presumptive remedy, which means a technology or technique where experience has shown the remedy to be a proven solution for specific types of sites and/or contaminant classes [See *DER-15: Presumptive/Proven Remedial Technologies* February 27, 2007. Refer to Section VI, Related References.]

Soil cleanup level, which means the concentration of a given contaminant for a specific site that must be achieved under a remedial program for soil. Depending on the regulatory program, a soil cleanup level may be based on the regulation [6 NYCRR 375-6.8(a) or (b)], modified from the regulatory value based on site-specific differences, or based on other information, including background levels or feasibility. Soil cleanup levels may include:

- SCOs promulgated at 6 NYCRR 375-6;
- Supplemental Soil Cleanup Objectives (SSCOs);
- a “totals” approach for a family of contaminants known as Polycyclic Aromatic Hydrocarbons (PAHs);
- Presumptive remedy for Polychlorinated Biphenyls (PCBs); and
- Nuisance Condition.

Soil Cleanup Objective (SCO), which means the chemical concentrations for soil cleanup of individual chemicals contained in 6 NYCRR 375-6.8(a) or (b). The SCOs were developed using the process outlined in the Technical Support Document (TSD). The SCOs and the SSCO defined below are applicable statewide and do not account for many site-specific considerations which could potentially result in higher levels. Soil concentrations that are higher than the SCOs and SSCO are not necessarily a health or environmental concern. When an SCO (or SSCO) is exceeded, the degree of public health or environmental concern depends on several factors, including the magnitude of the exceedance, the accuracy of the exposure estimates, other sources of exposure to the contaminant, and the strength and quality of the available toxicological information on the contaminant.

Supplemental Soil Cleanup Objective (SSCO), which means a) an existing soil cleanup level for a contaminant which had been included in former TAGM 4046 and was not included in 6 NYCRR 375-6; b) has been developed using the same process used for development of the SCOs; and c) new cleanup levels for soil developed by the remedial party following the approach detailed in Appendix E of the TSD. The TSD provides information relative to the development of cleanup objectives for soil that are not set forth in 6 NYCRR 375-6. Cleanup objectives that have been established at the direction of DEC or the election of remedial parties are included in Table 1.

Technical Support Document (TSD), which refers to the document dated December 2006 detailing the development of the SCOs that were promulgated in 6 NYCRR 375-6. It provides the technical background and provides a detailed discussion of the considerations for development of the SCOs for the different land uses and exposure pathways. The TSD is available on DEC’s website [see Section VI, Related References].

The purpose of this guidance is NOT to focus on media other than soil. Accordingly, the remedial program may require remedial activities to address media other than soil (e.g., groundwater, surface

water, sediment, and vapor). Applicable guidance should be consulted for media other than soil. This guidance is to be used in conjunction with the applicable statutes, regulations and guidance. Site-specific soil cleanup levels, determined in accordance with this guidance, are only applied after:

- the site, or area of concern, is fully investigated to determine the nature and extent of contamination;
- all sources of contamination are addressed consistent with the hierarchy provided in 6 NYCRR 375-1.8(c) or consistent with the RCRA Corrective Action Program (as appropriate);
- groundwater, if contaminated, has been evaluated for appropriate remedial actions consistent with 6 NYCRR 375-1.8(d) or consistent with the RCRA Corrective Action Program (as appropriate); and
- an evaluation of impacts on adjacent residential properties, surface water, aquatic ecological resources, as well as indoor air, soil vapor, vapor intrusion and other appropriate media.

IV. Responsibility

The responsibility for maintaining and updating this policy lies with DER. DEC staff are responsible for implementing this policy, with input (as applicable) from NYSDOH.

V. Procedures

A. General Approaches to the Selection of Soil Cleanup Levels

The determination of soil cleanup levels for a site is dependent on:

1. The regulatory program pursuant to which the site is being addressed;
2. Whether the groundwater beneath or down gradient of the site is, or may become contaminated with site-related contaminants;
3. Whether ecological resources constitute an important component of the environment at or adjacent to a site, and which are, or may be, impacted by site-related contaminants; and
4. Other impacted environmental media such as surface water, sediment, and soil vapor.

After fully evaluating the nature and extent of soil contamination associated with a site, the soil cleanup levels will be based on one, or a combination of, the following four approaches.

Approach 1: Utilize the Unrestricted Use Soil Cleanup Objectives [see 6 NYCRR Table 375-6.8(a)]. Under this approach, the soil cleanup levels will be established consistent with the SCOs set forth in 6 NYCRR Table 375-6.8(a). For contaminants of concern which are not included in the rule, DEC may direct development of a soil cleanup level which is protective of public health and the environment without restrictions following the procedure outlined in Appendix E of the TSD. Under this approach, the unrestricted SCOs are applied throughout the soil matrix to the top of bedrock (including the saturated zone).

Approach 2: Utilize the Restricted Use Soil Cleanup Objectives [see 6 NYCRR Table 375-6.8(b)]. Under this approach, soil cleanup levels will be established consistent with the SCOs set forth in 6 NYCRR Table 375-6.8(b) selecting the lowest SCO in the categories described in A

through C below. Generally, after source removal, the soil cleanup levels do not need to be achieved to more than 15 feet below ground surface or to the top of bedrock, whichever is shallower.

- A. Select the applicable land use category for the protection of public health (residential, restricted residential, commercial or industrial);
- B. Determine if the SCOs for the protection of groundwater are applicable (see Section V.D);
and
- C. Determine if the SCOs for the protection of ecological resources are applicable (see Section V.C).

Approach 3: Limited Site-Specific Modifications to Soil Cleanup Objectives. This approach allows for consideration of site-specific information to modify the SCOs promulgated in 6 NYCRR Tables 375-6.8 (a) and (b) following the approach detailed in Appendix E of the TSD. The equations and basic methodology specified for calculating the 6 NYCRR 375-6.8 (a) and (b) values may not be modified under this approach. However, in instances where site-specific parameters were used in the calculation of the SCOs, site data different from the assumptions used to calculate the SCOs may be used to modify the soil cleanup levels for a specific site. These instances are very limited and occur only in certain pathways that are listed below.

- Protection of groundwater pathway
- Particulate inhalation pathway
- Volatile inhalation pathway
- Protection of ecological resources pathway

It should be noted that even if site-specific data modifies these pathways, it may not result in modifying the SCOs because the lowest value from all applicable pathways is used to determine each SCO. The inhalation pathway is very seldom the controlling pathway in the determination of the protection of public health. The specific parameters that can be modified are identified in Appendix E of the TSD (e.g., inhalation dispersion terms, fraction of organic carbon in soil, etc.).

The remedial party should consider the cost of collecting the data necessary to support a request to modify the SCOs with the potential for deriving a higher SCO that provides an appropriate level of protection. The remedial party may be required to submit additional data to support the use of modified SCOs. Once DEC approves one or more modified SCOs, they are applied in the manner described under Approach 2.

Approach 4: Site-Specific Soil Cleanup Objectives. Under this approach, the remedial party may propose site-specific cleanup levels or approaches for soil which are protective of public health and the environment based on other information. This approach sets forth a flexible framework to develop soil cleanup levels by allowing the remedial party to conduct a more detailed evaluation of site information in an effort to calculate protective soil cleanup levels or approaches unique to a site. Under this approach, the remedial party may propose a remedy that does not include specific soil cleanup levels (e.g., excavate the top 6 feet in an area extending 75 feet in all directions from boring B12); modify the input parameters used in the SCO calculations; use site data to improve or confirm predictions of exposures to receptors to contaminants of concern; analyze site-specific risks using

risk assessments; use toxicological information available from alternate sources; or consider site background and historic fill. Data supporting these site-specific adjustments or use of alternate methodologies must also be provided to DEC for review and approval to ensure that the resulting soil cleanup levels are protective.

The Approach 4 framework leaves DEC with discretion to determine whether a different approach is appropriate for the site and, if a different approach is to be used, the proper method of implementation. The remedial party should consider the cost of collecting the data necessary to develop site-specific soil cleanup levels (or approaches) with the potential for deriving a soil cleanup level which is higher than a particular SCO and which provides an appropriate level of protection. The remedial party may also be required to submit additional data to support the use of methodologies in the calculation of site-specific soil cleanup levels or to support the proposed approach.

B. Application of Soil Cleanup Levels for the Specific Remedial Programs: Soil cleanup levels are determined on a site-specific basis depending on the program under which the site is being remediated. In some cases (e.g., BCP Track 1 or Track 2), the soil cleanup levels are the SCOs taken directly from 6 NYCRR 375-6. In other cases, soil cleanup levels may be derived from the Part 375 SCOs but modified based on other information. In yet other cases, the soil cleanup levels may have no relationship or connection to the SCOs, but rather be developed in accordance with DEC-approved methodologies or approaches.

1. Inactive Hazardous Waste Disposal Site Remedial Program (State Superfund Program): The goal of the remedial program for a specific site is to restore that site to pre-disposal conditions, to the extent feasible. The unrestricted use SCOs are considered to be representative of pre-disposal conditions unless an impact to ecological resources has been identified (see 6 NYCRR 375-2.8(b)(2)). However, it must be recognized that achievement of this goal may not be feasible in every case. At a minimum, all remedies must be protective of public health and the environment. The following procedure is used to determine the most feasible remedy.

- (a) The remedial party shall evaluate, and if feasible, implement a cleanup utilizing Approach 1 (application of unrestricted SCOs).
- (b) Where DEC determines that achieving unrestricted SCOs is not feasible as documented in a feasibility study, the remedial party may evaluate alternatives to remediate the site to the greatest extent feasible (see *DER-10: Technical Guidance for Site Investigation and Remediation*, Chapter 4.3). [See Section VI, Related References.] In this event, the remedial party may propose soil cleanup levels in accordance with any of the general approaches. However, when considering restricted use soil cleanup levels, the remedial party should apply the least restrictive use category feasible. For purposes of this discussion, residential use is the least restrictive use and industrial use is the most restrictive category. This process starts with consideration of residential use, followed by restricted residential use, commercial use, and then industrial use. The evaluation proceeds through the different land uses until a feasible remedy is found. This evaluation is not bound to the SCOs in regulation or SSCOs set forth in this guidance but may result in a site-specific soil cleanup level that is between the SCOs or soil cleanup level for two different land uses (e.g., above the restricted residential SCO and below the commercial SCO).

2. Brownfield Cleanup Program The remedy shall be fully protective of public health and the environment, including, but not limited to, groundwater according to its classification pursuant to ECL 17-0301, drinking water, surface water, air (including indoor air), sensitive populations (including children), and ecological resources (including fish and wildlife). Soil cleanup levels corresponding to the cleanup track under which the site is being remediated are required to be met. The four cleanup tracks are:

Track 1: Cleanups pursuant to this track must achieve unrestricted use of the site. This track requires that the remedial party implement a cleanup utilizing Approach 1. Institutional and engineering controls are allowed only for periods of less than five years (defined as short-term controls) except in the limited instance where a volunteer has conducted remedial activities resulting in a bulk reduction in groundwater contamination to asymptotic levels.

Track 2 : Cleanups pursuant to this track may consider the current, intended, or reasonably anticipated future use in determining the appropriate cleanup levels for soil. This track requires that the remedial party implement a cleanup that achieves the SCOs in the tables in 6 NYCRR 375-6.7(b) for the top 15 feet of soil (or bedrock if less than 15 feet). This track follows approach 2. Institutional and engineering controls are allowed for soil (for the top 15 feet of soil or bedrock if less than 15 feet) for less than five years (defined as short-term controls). Institutional and engineering controls which limit site use and the use of onsite groundwater can be used without regard to duration. Track 2 cleanups at restricted residential, commercial or industrial use sites require site management plans to ensure that material removed from the site (post remedial action) is managed appropriately and to ensure that any buffer zone protecting adjacent residential use sites or ecological resources is maintained.

Track 3: Cleanups pursuant to this track may consider the current, intended, or reasonably anticipated use in determining the appropriate cleanup levels for soil. This track requires that the remedial party implement a cleanup utilizing Approach 3 for those SCOs which the remedial party seeks to modify an established SCO. Institutional and engineering controls are allowed for soil (for the top 15 feet of soil or bedrock if less than 15 feet) for less than 5 years (defined as short-term controls). Institutional and engineering controls which limit site use and the use of on-site groundwater can be used without regard to duration. Track 3 cleanups at restricted residential, commercial or industrial use sites require site management plans to ensure that material removed from the site (post remedial action) is managed appropriately and to ensure that any buffer zone protecting adjacent residential use sites or ecological resources is maintained.

Track 4: Cleanups pursuant to this track may consider the current, intended, or reasonably anticipated use in determining the appropriate cleanup levels for soil. This track allows for the development of site-specific soil cleanup levels below the cover system in accordance with Approach 4. Track 4 remedies must address all sources as a component of the remedy. Short- and long-term institutional and engineering controls are allowed to achieve protection of public health and the environment. The remedy under Track 4 must provide a cover system over exposed residual soil contamination. Soils which are not otherwise covered by structures such as buildings, sidewalks or pavement (i.e., exposed surface soils) must be covered with soil that complies with the use-based SCOs in 6 NYCRR Table 375-6.8(b) levels for the top one foot (non-residential uses) or top two feet (restricted residential use).

3. Environmental Restoration Program: The goal of the program for a specific site is to select a remedy that is protective of public health and the environment, including, but not limited to, groundwater according to its classification pursuant to ECL 17-0301, drinking water, surface water and air (including indoor air), sensitive populations (including children) and ecological resources (including fish and wildlife). At a minimum, the remedy selected shall eliminate or mitigate all significant threats to public health and to the environment presented by contaminants disposed at the site through the proper application of scientific and engineering principles. Soil cleanup levels may be developed in accordance with Approaches 1 – 4 without restriction.

4. Voluntary Cleanup Program: The goal of the program for a specific site is to select a remedy that is protective of public health and the environment for the contemplated use. The soil cleanup levels may be developed in accordance with Approaches 1 – 4 without restriction.

5. Petroleum Spill Response Program: The goal of the Petroleum Spill Response Program is to achieve pre-spill conditions [6 NYCRR 611.6(a)(4)]. Remedial activities under this program shall be undertaken relative to the petroleum contamination that was released along with any co-mingled contamination from other sources. The remedial party shall achieve, to the extent feasible, the unrestricted SCOs for petroleum-related contaminants listed in 6 NYCRR Table 375-6.8(a). For petroleum contaminants not included in 6 NYCRR Table 375-6.8(a) (discussed in Section E below), the remedial party shall apply, to the extent feasible, the soil cleanup levels provided in Table 1. For ease of implementation, two lists of petroleum contaminants (Gasoline and Fuel Oil, Tables 2 and 3) are attached. The tables combine the applicable petroleum-related SCOs from 6 NYCRR 375-6.8(a) and the applicable petroleum related SSCOs from Table 1. Where DEC determines that it is not feasible to achieve the soil cleanup levels as set forth in this paragraph, the remedial party may propose soil cleanup levels in accordance with any of the general approaches. However, when considering restricted use soil cleanup levels, the remedial party should apply the least restrictive use category feasible.

For purposes of this discussion, residential use is the least restrictive use, and industrial use is the most restrictive category. This process starts with consideration of residential use, followed by restricted residential use, commercial use, and then industrial use. The evaluation proceeds through the different land uses until a feasible remedy is found. If the protection of groundwater or ecological SCOs apply, the lower of the applicable protection of the public health SCO or the applicable protection of groundwater or ecological SCO should be achieved to the extent feasible. This evaluation is not bound to the SCOs in regulation or the SSCOs set forth in this guidance but may result in a site-specific soil cleanup level that is between the SCOs or soil cleanup level for two different land uses (e.g., above the restricted residential SCO and below the commercial SCO).

6. RCRA Corrective Action Program: The RCRA program was promulgated to regulate facilities that actively manage hazardous waste. DER administers the RCRA Corrective Action Program, with a goal of achieving soil cleanup levels at Solid Waste Management Units (SWMUs) and Areas of Concern (AOCs) that eliminate risks to public health and the environment (i.e., clean the site to unrestricted use) or control said risks (i.e., clean the site or unit(s) to the lowest possible soil cleanup objective, regardless of site use), to the extent feasible. This goal takes into account that certain units at the facility may be permitted to manage hazardous waste under New York State's Hazardous Waste Management (HWM) regulations (6 NYCRR Part 373). The requirements of active HWM facilities, as well as the site's history, will be considered when soil cleanup levels are determined. Selected remedies must be protective of public health and the environment. Soil cleanup levels will be selected using the following procedure.

- (a) The remedial party shall evaluate, and if feasible, implement a cleanup utilizing Approach 1. Under this approach, the unrestricted SCOs apply to the entire soil matrix to the top of bedrock. For contaminants not listed in 6 NYCRR 375-6, a new or existing SSCO may be used.
- (b) If DEC determines that achieving unrestricted SCOs is not feasible, the remedial party may evaluate other alternatives to remediate the site. In this event, the remedial party may propose soil cleanup levels in accordance with any of the general approaches. However, when considering restricted use soil cleanup levels, the remedial party shall apply the use category which is both feasible and least restricted. For purposes of this discussion, residential use is the least restricted category and industrial use is the most restricted category. A soil cleanup level between two different land uses (e.g., residential and restricted residential) may be determined to be feasible, and if selected, must be achieved.

Any soil cleanup levels specified in regulation (i.e., 6 NYCRR 373-2.6(b)-(k) for “regulated units” as defined in 6 NYCRR 373-2.6 (a)(1)(ii)) or in a DEC enforceable document (Part 373 permits, Consent Orders, etc.) shall take precedence over the soil cleanup levels which could be established through use of this document.

C. Determination of Whether Ecological Resources SCOs Apply to a Site: SCOs developed to protect ecological resources (ESCOs) are incorporated in the Unrestricted Use SCO in 6 NYCRR Table 375-6.8(a) and are included as a separate category in 6 NYCRR Table 375-6.8(b). For contaminants of concern which do not have a calculated ESCO in regulation, DEC may direct the remedial party to develop a soil cleanup level which is protective of ecological resources where appropriate, based on the process outlined in Appendix E of the TSD.

The presence of ecological resources and any impact to those resources will be assessed during the remedial investigation. For sites where there is the potential for an ecological resource impact to be present, or where it is likely to be present, an assessment of fish and wildlife resource impacts will be performed. For sites in DER’s SSF, BCP, VCP and ERP, the assessment will be performed in accordance with DEC’s guidance, *Fish and Wildlife Impact Analysis for Inactive Hazardous Waste Sites*, October, 1994, as described in DER-10, Section 3.10. For sites in the RCRA Corrective Action Program, the assessment will be performed using the above referenced fish and wildlife impact analysis document as guidance, and by consulting with appropriate personnel in DEC’s Division of Fish, Wildlife and Marine Resources.

Soil cleanup levels which are protective of ecological resources must be considered and applied, as appropriate, for the upland soils (not sediment) at sites where DEC determines, based on the foregoing analysis, that:

- ecological resources are present, or will be present, under the reasonably anticipated future use of the site, and such resources constitute an important component of the environment at, or adjacent to, the site;
- an impact or threat of impact to the ecological resource has been identified; and
- contaminant concentrations in soil exceed the ESCOs as set forth in 6 NYCRR 375-6.8(b) or the Protection of Ecological Resources SSCOs contained in this document.

Sites or portions thereof that will be covered by buildings, structures or pavement are not subject to the ESCOs. Further, ecological resources do not include pets, livestock, agricultural or horticultural crops, or landscaping in developed areas. (See 6 NYCRR 375-6.6 for more detail.)

D. Determination of Whether Protection of Groundwater SCOs Apply: SCOs developed to protect groundwater are incorporated in the Unrestricted Use SCOs in 6 NYCRR Table 375-6.8(a) and are included as a separate category in 6 NYCRR Table 375-6.8(b). For contaminants of concern which do not have a protection of groundwater SCO, DEC may direct the remedial party to develop a soil cleanup level which is protective of groundwater using the process in Appendix E of the TSD.

1. Except as provided for in (2) below, the protection of groundwater SCOs will be applicable where:
 - (i) contamination has been identified in on-site soil by the remedial investigation; and
 - (ii) groundwater standards are, or are threatened to be, contravened by the presence of soil contamination at concentrations above the protection of groundwater SCOs.
2. DEC may provide an exception to the applicability of the protection of groundwater SCOs, as set forth in 6 NYCRR 375-6.5(a)(1), when (i), (ii), and (iii) exist and either (iv) or (v) also apply, as described below.
 - (i) The groundwater standard contravention is the result of an on-site source which is addressed by the remedial program.
 - (ii) An environmental easement or other institutional control will be put in place which provides for a groundwater use restriction.
 - (iii) DEC determines that contaminated groundwater at the site:
 - (a) is not migrating, nor is likely to migrate, off-site; or
 - (b) is migrating, or is likely to migrate, off-site; however, the remedy includes active groundwater management to address off-site migration.
 - (iv) DEC determines the groundwater quality will improve over time.
 - (v) The groundwater contamination migrating from the site is the result of an off-site source of contamination, and site contaminants are not contributing consequential amounts to the groundwater contamination.
3. In determining whether to provide the exemption set forth in subparagraph 2 above, DEC will consider:
 - (i) all of the remedy selection criteria at 6 NYCRR 375-1.8(h) or in the RCRA Corrective Action program;
 - (ii) the amount of time that the groundwater will need to be actively managed for the protection of public health and the environment; and
 - (iii) the potential impact that groundwater contamination may have on media not specifically addressed by the SCOs (e.g., vapor intrusion, protection of surface water, and protection of aquatic ecological resources).

E. Supplemental Soil Cleanup Objectives: SSCOs are either existing cleanup levels in Table 1 or are new soil cleanup levels developed by the remedial party as part of its remedial program. These SSCOs are in addition to the SCOs that are included in Part 375.

Existing SSCOs: The Table 1 list of SSCOs includes contaminants from former TAGM 4046 that were not included in 6 NYCRR 375-6.8 and soil cleanup levels developed using the process detailed in Appendix E of the TSD but not promulgated. For those contaminants which were part of the former TAGM 4046, soil cleanup levels exist for the protection of public health (based on ingestion) and for the protection of groundwater. In some cases, to be determined on a site-by-site basis, evaluation of other factors is likely needed for the protection of public health, especially when the use of a site includes residential use.

These other factors include other exposure pathways (e.g., homegrown vegetable ingestion, inhalation and dermal contact), potential non-site exposures to the contaminant and current toxicological data on the contaminant. In these instances, DEC (in consultation with NYSDOH) will determine if the additional factors have been adequately addressed. The SSCOs identified in Table 1 (subject to the limitation described above) may be used as if they were included in Part 375. A remedial party is not required to use the SSCOs set forth in Table 1. In lieu of applying an SSCO, the remedial party may elect to develop a soil cleanup level (using the process described in Appendix E of the TSD and discussed below.) Table 1 also includes SSCOs that were developed for some pathways using the same process detailed in the TSD. A remedial party may elect to use those SSCOs directly or confirm that the calculated value for that pathway is correct.

New SSCOs: The remedial party may elect to, or DEC may direct a remedial party to, develop a contaminant-specific SCO for any contaminant not included in 6 NYCRR Tables 375-6.8(a) or (b). Generally, DEC will request that an SCO be developed only where the contaminant is a predominant contaminant of concern (COC) at the site and is not otherwise being addressed to DEC's satisfaction as part of the proposed remedy. This could happen, for example, when a remedial party is seeking a Track 1 cleanup and non-SCO/SSCO contaminants are present and may not be satisfactorily addressed by the remedial activities addressing the SCOs or SSCOs. Guidance on the process for developing new SCOs is provided in Appendix E of the TSD. DEC will include all newly developed soil cleanup levels, developed and approved pursuant to this paragraph in a revised Table 1. The developed SSCO must:

1. be developed utilizing the same methodologies that were used by DEC to develop SCOs that are set forth in Part 375; and
2. apply the maximum acceptable soil concentrations (caps), as set forth in section 9.3 of the TSD.

F. Use of SCOs and SSCOs as a Screening Tool: The SCOs and SSCOs may be used to identify areas of soil contamination and to determine the extent of soil contamination. As noted in Section V.K, consideration of other media is required to determine if remedial action is needed.

1. At sites or areas of concern where contaminant concentrations are equal to or below the unrestricted SCOs in 6 NYCRR Table 375-6.8(a), no action or study is warranted because of soil contamination.

2. The exceedance of one or more applicable SCOs or SSCOs, (which is the lower of protection of public health, protection of groundwater, or protection of ecological resources soil cleanup objectives as described in Section III below), alone does not trigger the need for remedial action, define “unacceptable” levels of contaminants in soil, or indicates that a site qualifies for any DEC remedial program (e.g., BCP, SSF). As noted in the definition of SCO above, SCOs and SSCOs are applicable statewide and do not account for many site-specific considerations which could potentially result in higher levels. Therefore, soil concentrations that are higher than the applicable SCOs or SSCOs are not necessarily health or environmental concerns.
3. When an applicable SCO or SSCO is exceeded, the degree of public health or environmental concern depends on several factors, including:
 - magnitude of the exceedance;
 - accuracy of the exposure estimates;
 - other sources of exposure to the contaminant; and
 - strength and quality of the available toxicological information on the contaminant.

G. Soil Cleanup Levels for Nuisance Conditions: Experience has shown that contaminants in soil that meets the DEC-approved soil cleanup levels can exhibit a distinct odor or other type of nuisance (e.g., staining). This is true even though the contaminants will not leach from the soil (e.g., certain soils with more insoluble substances at higher concentrations). When DEC determines that soil remaining after the remedial action will result in the continuation of a nuisance (e.g., odors, staining, etc), DEC will require that additional remedial measures be evaluated, and may require additional remedial actions be taken to address the nuisance condition.

H. Subsurface Soil Cleanup for Total Polycyclic Aromatic Hydrocarbons: For non-residential use sites (i.e., commercial or industrial use sites) where the ESCOs are not applicable, DEC may approve a remedial program which achieves a soil cleanup level of 500 parts per million (ppm) for total PAHs for all subsurface soil. The 500 ppm soil cleanup level is in lieu of achieving all of the PAH-specific SCOs in 6 NYCRR 375-6. For purposes of this provision, subsurface soil shall mean the soil beneath permanent structures, pavement, or similar cover systems; or at least one foot of soil cover (which must meet the applicable SCOs). Institutional controls (e.g., an environmental easement) along with a site management plan will be required when this soil cleanup level is employed at a site. This cleanup level is determined to be feasible and protective based on DEC's experience in its various remedial programs. This approach has existed in TAGM 4046 since it was first issued in 1992.

I. Soil Cleanup for PCBs: DEC may approve a remedial program which achieves a soil cleanup level for PCBs as set forth herein:

1. **For Non-BCP sites:** An acceptable presumptive remedy for soil where neither the unrestricted SCOs nor the ESCOs are applied in the remedial program may include a soil cleanup level for PCBs of 1 ppm in the surface soils and 10 ppm in subsurface soils.
2. **For BCP sites:** An acceptable presumptive remedy for soil may include a soil cleanup level for PCBs of 1 ppm (the applicable SCO) in the surface soils and 10 ppm in subsurface in limited circumstances as follows:

- cleanup track is Track 4;
 - site use will be restricted residential, commercial or industrial; and
 - ESCOs do not apply.
3. **At industrial use sites**, a level of 25 ppm for PCBs provided that access is limited and individual occupancy is restricted to less than an average of 6.7 hours per week.

For purposes of this provision, subsurface soil shall mean:

- soil beneath permanent structures, pavement, or similar cover systems;
- soil beneath 1 foot of soil cover for commercial and industrial uses; or
- soil beneath 2 feet of soil cover for residential and restricted residential uses.

Institutional controls (i.e., an environmental easement), along with a site management plan, will be required when this soil cleanup level is employed at a site. As with all presumptive remedies, just because a remedy is presumptive does not mean that it will work at every site. For example, this presumptive remedy for PCBs in soil is not applicable at most landfills. This cleanup level is determined to be feasible and protective based on DEC's experience in its various remedial programs. Further, this approach has existed in TAGM 4046 since it was first issued in 1992.

J. Sampling and Compliance with Soil Cleanup Levels: The number of samples to determine if the SCOs have been achieved should be sufficient to be representative of the area being sampled. See attached Table 4 for suggested sampling frequency and subdivision 5.4(e) of DER-10 for details. This frequency can be used for confirmatory samples or for backfill. It is DEC's goal that all confirmatory samples demonstrate that the remedy has achieved the DEC-approved soil cleanup levels. However, recognizing the heterogeneity of contaminated sites and the uncertainty of sampling and analysis, DEC project manager has limited discretion to determine that remediation is complete where some discrete samples do not meet the soil cleanup levels established for a site. See DER-10 for more information regarding the determination that remediation is complete.

K. Other Considerations: All remedies must be fully protective of public health and the environment and prevent off-site migration to the extent feasible with special emphasis for the prevention or minimization of migration onto adjacent residential properties or into ecological resources. A remedial party is required to investigate all environmental media including soil, groundwater, surface water, sediments, soil vapor, indoor air, and biota. (See 6 NYCRR 375-1.8(a)(6) or RCRA Corrective Action Program). This investigation will determine if any of the referenced media are, or may be, impacted by site contamination. However, the SCOs do not directly address these other media. DEC may require remedial actions to address such media and impacts, including but not limited to the application of lower soil cleanup levels or buffer zones where it determines, based on the investigation, that any of these media are, or may be, impacted by site contamination.

VI. Related References:

- ◆ Environmental Conservation Law, Article 27 Titles 3, 5, 9, 13 and 14.
- ◆ Article 12 of the Navigation Law, Section 178.

- ◆ 6 NYCRR Part 375, Environmental Remediation Programs. December 14, 2006.
- ◆ 6 NYCRR Subparts 373-1, 373-2 and 373-3, Requirements for Hazardous Waste Management Facilities. September 6, 2006.
- ◆ 6 NYCRR Part 611, Environmental Priorities and Procedures in Petroleum Cleanup and Removal. November 5, 1984 (amended).
- ◆ [Development of Soil Cleanup Objectives: Technical Support Document](#). New York State Department of Environmental Conservation. December 14, 2006.
- ◆ Supplemental Guidance to RAGS: Calculating the Concentration Term. United States Environmental Protection Agency. Publication 9285.7-081. May 1992.
- ◆ New York State Guidelines for Urban Erosion and Sediment Control. 1997.
- ◆ Fish and Wildlife Impact Analysis for Inactive Hazardous Waste Sites. New York State Department of Environmental Conservation. October 1994.
- ◆ [Program Policy DER-2, Making Changes to Selected Remedies](#). New York State Department of Environmental Conservation. April 1, 2008.
- ◆ [Program Policy DER-10, Technical Guidance for Site Investigation and Remediation](#). New York State Department of Environmental Conservation. May 3, 2010.
- ◆ [Program Policy DER-15, Presumptive/Proven Remedial Technologies](#). New York State Department of Environmental Conservation. February 27, 2007.

TABLES

- 1 - Supplemental Soil Cleanup Objectives**
- 2 - Soil Cleanup Levels for Gasoline Contaminated Soils**
- 3 - Soil Cleanup Levels for Fuel Oil Contaminated Soils**
- 4 - Recommended Number of Soil Samples for Soil Imported to or Exported From a Site**

Table 1
Supplemental Soil Cleanup Objectives
(ppm)

Contaminant	CAS Number	Residential	Restricted Residential	Commercial	Industrial	Protection of Ecological Resources	Protection of Ground-water
METALS							
Aluminum	7429-90-5					10,000 ^{a,b}	
Antimony	7440-36-0					12 ^c	
Boron	7440-42-8					0.5	
Calcium	7440-70-2					10,000 ^{a,b}	
Cobalt	7440-48-4	30				20	
Iron	7439-89-6	2,000					
Lithium	7439-93-2					2	
Molybdenum	7439-98-7					2	
Technetium	7440-26-8					0.2	
Thallium	7440-28-0					5 ^c	
Tin	7440-31-5					50	
Uranium	7440-61-1					5	
Vanadium	7440-62-2	100 ^a				39 ^b	
PESTICIDES							
Biphenyl	92-52-4					60	
Chlordecone (Kepone)	143-50-0					0.06	
Dibenzofuran	132-64-9						6.2
2,4-D (2,4-Dichloro-phenoxyacetic acid)	94-75-7	100 ^a					0.5
Furan	110-00-9					600	
Gamma Chlordane	5103-74-2	0.54					14
Heptachlor Epoxide	1024-57-3	0.077					0.02
Methoxychlor	72-43-5	100 ^a				1.2	900

Contaminant	CAS Number	Residential	Restricted Residential	Commercial	Industrial	Protection of Ecological Resources	Protection of Ground-water
Parathion	56-38-2	100 ^a					1.2
2,4,5-T	93-76-5	100 ^a					1.9
2,3,7,8-TCDD	1746-01-6					0.000001	
2,3,7,8-TCDF	51207-31-9					0.000001	
SEMIVOLATILE ORGANIC COMPOUNDS							
Aniline	62-53-3	48	100 ^a	500 ^a	1000 ^a		0.33 ^b
Bis(2-ethylhexyl) phthalate	117-81-7	50				239	435
Benzoic Acid	65-85-0	100 ^a					2.7
Butylbenzyl-phthalate	85-68-7	100 ^a					122
4-Chloroaniline	106-47-8	100 ^a					0.22
Chloroethane	75-00-3						1.9
2-Chlorophenol	95-57-8	100 ^a				0.8	
3-Chloroaniline	108-42-9					20	
3-Chlorophenol	108-43-0					7	
Di-n-butyl-phthalate	84-74-2	100 ^a				0.014	8.1
2,4-Dichlorophenol	120-83-2	100 ^a				20	0.40
3,4-Dichlorophenol	95-77-2					20	
Diethylphthalate	84-66-2	100 ^a				100	7.1
Di-n-hexyl-phthalate	84-75-3					0.91	
2,4-Dinitrophenol	51-28-5	100 ^a				20	0.2
Dimethylphthlate	131-11-3	100 ^a				200	27
Di-n-octylphthlate	117-84-0	100 ^a					120
1,2,3,6,7,8-HCDF	57117-44-9					0.00021	
Hexachloro-benzene	118-74-1	0.41					1.4
2,6-Dinitrotoluene	606-20-2	1.03					1.0
Isophorone	78-59-1	100 ^a					4.4

Contaminant	CAS Number	Residential	Restricted Residential	Commercial	Industrial	Protection of Ecological Resources	Protection of Ground-water
4-methyl-2-pentanone	108-10-1						1.0
2-methyl-naphthalene	91-57-6	0.41					36.4
2-Nitroaniline	88-74-4						0.4
3-Nitroaniline	99-09-2						0.5
Nitrobenzene	98-95-3	3.7	15	69	140	40	0.17 ^b
2-Nitrophenol	88-75-5					7	0.3
4-Nitrophenol	100-02-7					7	0.1
Pentachloroaniline	527-20-8					100	
2,3,5,6-Tetrachloroaniline	3481-20-7					20	
2,3,4,5-Tetrachlorophenol	4901-51-3					20	
2,4,5-Trichloroaniline	636-30-6					20	
2,4,5-Trichlorophenol	95-95-4	100 ^a				4	0.1
2,4,6-Trichlorophenol	88-06-2					10	
VOLATILE ORGANIC COMPOUNDS							
2-Butanone	78-93-3	100 ^a					0.3
Carbon Disulfide	75-15-0	100 ^a					2.7
Chloroacetamide	79-07-2					2	
Dibromochloromethane	124-48-1					10	
2,4-Dichloro aniline	554-00-7					100	
3,4-Dichloroaniline	95-76-1					20	
1,2-Dichloropropane	78-87-5					700	
1,3-Dichloropropane	142-28-9						0.3
2,6-Dinitrotoluene	606-20-2	1.03					0.17 ^b
Ethylacetate	141-78-6					48	

Contaminant	CAS Number	Residential	Restricted Residential	Commercial	Industrial	Protection of Ecological Resources	Protection of Ground-water
4-methyl-2-pentanone	108-10-1						1.0
113 Freon (1,1,2- TFE)	76-13-1	100 ^a					6
isopropylbenzene	98-82-8	100 ^a					2.3
p-isopropyltoluene	99-87-6						10
Hexachlorocyclopentadiene	77-47-4					10	
Methanol	67-56-1					6.5	
N-nitrosodiphenylamine	86-30-6					20	
Pentachlorobenzene	608-93-5					20	
Pentachloronitrobenzene	82-68-8					10	
Styrene	100-42-5					300	
1,2,3,4-Tetrachlorobenzene	634-66-2					10	
1,1,2,2-Tetrachloroethane	79-34-5	35					0.6
1,1,2,2-Tetrachloroethylene	127-18-4					2	
1,2,3-Trichlorobenzene	87-61-6					20	
1,2,4-Trichlorobenzene	120-82-1					20	3.4
1,2,3-Trichloropropane	96-18-4	80					0.34

^a SCOs for organic contaminants (volatile organic compounds, semivolatile organic compounds, and pesticides) are capped at 100 ppm for residential use, 500 ppm for commercial use, 1000 ppm for industrial use. SCOs for metals are capped at 10,000 ppm.

^b Based on rural background study

^c SCO limited by contract required quantitation limit.

Table 2**Soil Cleanup Levels for Gasoline Contaminated Soils**

Contaminant	CAS Registry Number	Soil Cleanup Level (ppm)
Benzene	71-43-2	0.06
n-Butylbenzene	104-51-8	12.0
sec-Butylbenzene	135-98-8	11.0
Ethylbenzene	100-41-4	1.0
Isopropylbenzene	98-82-8	2.3
p-Isopropyltoluene	99-87-6	10.0
Methyl-Tert-Butyl-Ether	1634-04-4	0.93
Naphthalene	91-20-3	12.0
n-Propylbenzene	103-65-1	3.9
Tert-Butylbenzene	98-06-6	5.9
Toluene	108-88-3	0.7
1,2,4-Trimethylbenzene	95-63-6	3.6
1,3,5-Trimethylbenzene	108-67-8	8.4
Xylene (Mixed)	1330-20-7	0.26

Table 3**Soil Cleanup Levels for Fuel Oil Contaminated Soil**

Contaminant	CAS Registry Number	Soil Cleanup Level (ppm)
Acenaphthene	83-32-9	20
Acenaphthylene	208-96-8	100
Anthracene	120-12-7	100
Benz(a)Anthracene	56-55-3	1.0
Dibenzo(a,h)Anthracene	53-70-3	0.33
Benzene	71-43-2	0.06
n-Butylbenzene	104-51-8	12.0
sec-Butylbenzene	135-98-8	11.0
Tert-Butylbenzene	98-06-6	5.9
Chrysene	218-01-9	1.0
Ethylbenzene	100-41-4	1.0
Fluoranthene	206-44-0	100
Benzo(b)Fluoranthene	205-99-2	1.0
Benzo(k)Fluoranthene	207-08-9	0.8
Fluorene	86-73-7	30
Isopropylbenzene	98-82-8	2.3
p-Isopropyltoluene	99-87-6	10.0
Naphthalene	91-20-3	12.0
n-Propylbenzene	103-65-1	3.9
Benzo(g,h,i)Perylene	191-24-2	100
Phenanthrene	85-01-8	100
Pyrene	129-00-0	100
Benzo(a)Pyrene	50-32-8	1.0
Indeno(1,2,3-cd)Pyrene	193-39-5	0.5
1,2,4-Trimethylbenzene	95-63-6	3.6
1,3,5-Trimethylbenzene	108-67-8	8.4
Toluene	108-88-3	0.7
Xylene (Mixed)	1330-20-7	0.26

Table 4

Recommended Number of Soil Samples for Soil Imported To or Exported From a Site

Contaminant	VOCs ^a		SVOCs, Inorganics & PCBs/Pesticides	
	Soil Quantity (cubic yards)	Discrete Samples	Composite	Discrete Samples/Composite
0-50	1	1	Each composite sample for analysis is created from 3-5 discrete samples from representative locations in the fill.	
50-100	2	1		
100-200	3	1		
200-300	4	1		
300-400	4	2		
400-500	5	2		
500-800	6	2		
800-1000	7	2		
➤ 1000	Add an additional 2 VOC and 1 composite for each additional 1000 Cubic yards or consult with DER. ^b			

^a VOC samples cannot be composited. Discrete samples must be taken to maximize the representativeness of the results.

^b For example, a 3,000 cubic yard soil pile to be sampled and analyzed for VOCs would require 11 discrete representative samples. The same pile to be sampled for SVOCs would require 4 composite samples with each composite sample consisting of 3-5 discrete samples.

Appendix I – SWPPP Amendments

The Owner/Operator shall have a Qualified Professional amend the SWPPP when one or more of the following occur:

- There is a significant change in design, construction, operation, or maintenance which may have a significant effect on the potential for the discharge of pollutants to the waters of the United States and which has not otherwise been addressed in the SWPPP; or
- The SWPPP proves to be ineffective in:
 - Eliminating or significantly minimizing pollutants from sources identified in the SWPPP and as required by this permit; or
 - Achieving the general objectives of controlling pollutants in stormwater discharges from permitted construction activity.

Additionally, the SWPPP shall be amended to identify any new Contractor or Subcontractor that will implement any measure of the SWPPP.

The following information should be documented in this section:

- Dates when major grading activities occur;
- Dates when construction activities temporarily or permanently cease on a portion of the Project Area; and
- Dates when stabilization measures (temporary and permanent) are initiated.

Appendix J – SWPPP Inspection Reports

- Blank SWPPP Inspection Form -
- Completed SWPPP Inspection Reports -

Appendix J – Blank SWPPP Inspection Form



General Project Information			
Project Name:			
SPDES Permit Number:		Type of Construction Activities Being Completed:	
Date of Inspection:			
Inspector's Name:			
Time On Site:			
Time Off Site:		Inspection Type:	
General Project Notes:			
SWPPP Amendment Required:	<input type="checkbox"/> Yes	<input type="checkbox"/> No	If yes, describe:

Weather Information		
Has there been a storm event since the last inspection?	<input checked="" type="checkbox"/> Yes	<input type="checkbox"/> No
If yes, what was the approx. amount of precipitation (inches) since the last inspection:		
Weather conditions at the time of inspection?	Temperature: °F	
<input type="checkbox"/> Clear <input type="checkbox"/> Cloudy <input type="checkbox"/> Rain <input type="checkbox"/> Sleet <input type="checkbox"/> Snow <input type="checkbox"/> Fog <input type="checkbox"/> High Winds		
Does the Project Site discharge to natural surface waterbodies located within or immediately adjacent to the Project area?	<input type="checkbox"/> Yes	<input type="checkbox"/> No
If yes, describe:		
Were there any discharges observed at the time of inspection?	<input type="checkbox"/> Yes	<input type="checkbox"/> No
If yes, were sediment laden discharges observed?	<input type="checkbox"/> Yes	<input type="checkbox"/> No
Describe:		
If yes, was erosion or sedimentation observed at the discharge location?	<input type="checkbox"/> Yes	<input type="checkbox"/> No
Describe:		
Soil Condition:		
Were areas of soil disturbance observed at the time of inspection?	<input type="checkbox"/> Yes	<input type="checkbox"/> No
If yes, describe:		

Maintaining Water Quality

Water Quality Observations	Yes	No	N/A
Is there an increase in turbidity causing a substantial visual contrast to natural conditions?	<input type="checkbox"/>	<input type="checkbox"/>	<input type="checkbox"/>
Is there residue from oil and floating substances, visible oil film, or grease or globules?	<input type="checkbox"/>	<input type="checkbox"/>	<input type="checkbox"/>
Are all disturbances within the approved limits, as outlined on the plans?	<input type="checkbox"/>	<input type="checkbox"/>	<input type="checkbox"/>
Have receiving waterbodies and/or wetland been impacted by the Project?	<input type="checkbox"/>	<input type="checkbox"/>	<input type="checkbox"/>
Are the concrete washout facilities located a minimum of 100 feet from sensitive areas and properly maintained?	<input type="checkbox"/>	<input type="checkbox"/>	<input type="checkbox"/>
Comments:			

General Housekeeping

Site Conditions	Yes	No	N/A
Is construction site litter and debris appropriately managed?	<input type="checkbox"/>	<input type="checkbox"/>	<input type="checkbox"/>
Are facilities and equipment necessary for implementation of erosion and sediment controls in working and/or properly maintained?	<input type="checkbox"/>	<input type="checkbox"/>	<input type="checkbox"/>
Is construction impacting adjacent properties?	<input type="checkbox"/>	<input type="checkbox"/>	<input type="checkbox"/>
Is dust adequately controlled?	<input type="checkbox"/>	<input type="checkbox"/>	<input type="checkbox"/>
Comments:			



Runoff Control Practices

Temporary Stream Crossings	Yes	No	N/A
Are the maximum necessary diameter pipes installed to span stream without dredging?	<input type="checkbox"/>	<input type="checkbox"/>	<input type="checkbox"/>
Is non-woven geotextile fabric installed beneath the approaches?	<input type="checkbox"/>	<input type="checkbox"/>	<input type="checkbox"/>
Is fill composed of aggregate (no earthen or soil material)?	<input type="checkbox"/>	<input type="checkbox"/>	<input type="checkbox"/>
Is the rock on approaches clean enough to remove mud/sediment from vehicles and prevent sediment from entering the stream during high flows?	<input type="checkbox"/>	<input type="checkbox"/>	<input type="checkbox"/>
Comments:			

Excavation Dewatering	Yes	No	N/A
Are upstream and downstream berms (sandbags, inflatable dams, etc.) are installed per the Construction Drawings?	<input type="checkbox"/>	<input type="checkbox"/>	<input type="checkbox"/>
Is clean water from the upstream pool being pumped to the downstream pool?	<input type="checkbox"/>	<input type="checkbox"/>	<input type="checkbox"/>
Is sediment laden water from the work area being discharged to a sediment trapping device?	<input type="checkbox"/>	<input type="checkbox"/>	<input type="checkbox"/>
Is the water discharging from the sediment trapping device clear and free of sediment?	<input type="checkbox"/>	<input type="checkbox"/>	<input type="checkbox"/>
Does the constructed upstream berm have a minimum of one-foot freeboard?	<input type="checkbox"/>	<input type="checkbox"/>	<input type="checkbox"/>
Comments:			

Flow Spreader(s)	Yes	No	N/A
Is the flow spreader installed per the Construction Drawings?	<input type="checkbox"/>	<input type="checkbox"/>	<input type="checkbox"/>
Was the flow spreader constructed on undisturbed soil, not on fill?	<input type="checkbox"/>	<input type="checkbox"/>	<input type="checkbox"/>
Does the flow spreader receive only clear, non-sediment laden flows?	<input type="checkbox"/>	<input type="checkbox"/>	<input type="checkbox"/>
Does the discharge from the flow spreader sheet flow out of the spreader without erosion downstream?	<input type="checkbox"/>	<input type="checkbox"/>	<input type="checkbox"/>
Comments:			

Interceptor Dikes and Swales	Yes	No	N/A
Is the dike/swale installed per the Construction Drawings?	<input type="checkbox"/>	<input type="checkbox"/>	<input type="checkbox"/>
Has the dike/swale been stabilized by geotextile fabric, seed, and/or mulch?	<input type="checkbox"/>	<input type="checkbox"/>	<input type="checkbox"/>
Was erosion observed within the dike/swale?	<input type="checkbox"/>	<input type="checkbox"/>	<input type="checkbox"/>
Is sediment-laden runoff directed to a sediment trapping device?	<input type="checkbox"/>	<input type="checkbox"/>	<input type="checkbox"/>
Comments:			

Stone Check Dam(s)	Yes	No	N/A
Are the check dams in good condition (rocks in place and no ponding behind the dams)?	<input type="checkbox"/>	<input type="checkbox"/>	<input type="checkbox"/>
Has geotextile fabric been placed beneath the rock fill?	<input type="checkbox"/>	<input type="checkbox"/>	<input type="checkbox"/>
Was sediment accumulation greater than 50% of the design capacity?	<input type="checkbox"/>	<input type="checkbox"/>	<input type="checkbox"/>
Was erosion observed within the channel?	<input type="checkbox"/>	<input type="checkbox"/>	<input type="checkbox"/>
Comments:			



Rock Outlet Protection	Yes	No	N/A
Is the rock outlet protection installed per approved plans?	<input type="checkbox"/>	<input type="checkbox"/>	<input type="checkbox"/>
Was the outlet protection installed concurrently with pipe installation?	<input type="checkbox"/>	<input type="checkbox"/>	<input type="checkbox"/>
Have the rocks been displaced?	<input type="checkbox"/>	<input type="checkbox"/>	<input type="checkbox"/>
Is the sediment accumulation 0% of the design capacity?	<input type="checkbox"/>	<input type="checkbox"/>	<input type="checkbox"/>
Comments:			

Soil Stabilization

Topsoil and Spoil Stockpiles	Yes	No	N/A
Are stockpiles properly stabilized and contained?	<input type="checkbox"/>	<input type="checkbox"/>	<input type="checkbox"/>
Are sediment control installed at the toe of the slope?	<input type="checkbox"/>	<input type="checkbox"/>	<input type="checkbox"/>
Are idle soil stockpiles are stabilized with vegetation and/or mulch?	<input type="checkbox"/>	<input type="checkbox"/>	<input type="checkbox"/>
Comments:			

Revegetation	Yes	No	N/A
Has temporary seed and mulch been applied to idle areas?	<input type="checkbox"/>	<input type="checkbox"/>	<input type="checkbox"/>
Has a minimum of 4 inches of topsoil been applied under permanent seeding areas?	<input type="checkbox"/>	<input type="checkbox"/>	<input type="checkbox"/>
Comments:			

Sediment Control Practices

Stabilized Construction Entrance(s)	Yes	No	N/A
Is the entrance installed per the Construction Drawings?	<input type="checkbox"/>	<input type="checkbox"/>	<input type="checkbox"/>
Is the stone clean enough to effectively remove mud/sediment from vehicle tires?	<input type="checkbox"/>	<input type="checkbox"/>	<input type="checkbox"/>
Does all traffic enter and exit the site at the stabilized construction entrance(s)?	<input type="checkbox"/>	<input type="checkbox"/>	<input type="checkbox"/>
Is adequate drainage provided to prevent ponding at the entrance(s)?	<input type="checkbox"/>	<input type="checkbox"/>	<input type="checkbox"/>
Comments:			

Linear Sediment Control Barriers	Yes	No	N/A
Are the sediment controls installed along the contour, 10 feet from toe of slope and not within conveyance channels?	<input type="checkbox"/>	<input type="checkbox"/>	<input type="checkbox"/>
Are silt fence joints constructed by wrapping the two ends together for continuous support?	<input type="checkbox"/>	<input type="checkbox"/>	<input type="checkbox"/>
Is the silt fence fabric is buried a minimum of 6 inches?	<input type="checkbox"/>	<input type="checkbox"/>	<input type="checkbox"/>
Are the posts stable and the fabric is tight and without rips/frayed areas?	<input type="checkbox"/>	<input type="checkbox"/>	<input type="checkbox"/>
Does the compost filter sock have good contact with the soil?	<input type="checkbox"/>	<input type="checkbox"/>	<input type="checkbox"/>
Is the sediment accumulation 0% of the design capacity?	<input type="checkbox"/>	<input type="checkbox"/>	<input type="checkbox"/>
Comments:			



Storm Drain Inlet Protection	Yes	No	N/A
Is the inlet protection installed in accordance with the Construction Drawings?	<input type="checkbox"/>	<input type="checkbox"/>	<input type="checkbox"/>
Is the inlet protection structurally sound?	<input type="checkbox"/>	<input type="checkbox"/>	<input type="checkbox"/>
Are the posts stable and the fabric is tight and without rips/frayed areas?	<input type="checkbox"/>	<input type="checkbox"/>	<input type="checkbox"/>
Is the sediment accumulation greater than 50% of the design capacity?	<input type="checkbox"/>	<input type="checkbox"/>	<input type="checkbox"/>
Comments:			

Temporary Sediment Basin	Yes	No	N/A
Is the basin and outlet structure constructed per the Construction Drawings?	<input type="checkbox"/>	<input type="checkbox"/>	<input type="checkbox"/>
Are the basin side slopes stabilized?	<input type="checkbox"/>	<input type="checkbox"/>	<input type="checkbox"/>
Was the drainage structure flushed and basin surface restored upon removal of the sediment basin facility?	<input type="checkbox"/>	<input type="checkbox"/>	<input type="checkbox"/>
Is the sediment basin dewatering at an appropriate rate?	<input type="checkbox"/>	<input type="checkbox"/>	<input type="checkbox"/>
Is the sediment accumulation greater than 50% of the design capacity?	<input type="checkbox"/>	<input type="checkbox"/>	<input type="checkbox"/>
Comments:			

Temporary Sediment Trap	Yes	No	N/A
Is the outlet structure constructed per the Construction Drawings?	<input type="checkbox"/>	<input type="checkbox"/>	<input type="checkbox"/>
Has geotextile fabric been placed beneath the rock fill?	<input type="checkbox"/>	<input type="checkbox"/>	<input type="checkbox"/>
Are the sediment trap slopes and disturbed areas are stabilized?	<input type="checkbox"/>	<input type="checkbox"/>	<input type="checkbox"/>
Is the sediment accumulation greater than 50% of the design capacity?	<input type="checkbox"/>	<input type="checkbox"/>	<input type="checkbox"/>
Comments:			

Note: Not all erosion and sediment control practices are included in this listing. Add additional pages to this list as required by site specific design. All practices shall be maintained in accordance with their respective standards.

Qualified Inspector

Qualified Inspector Signature





Qualified Professional

Qualified Professional Signature

The above signed acknowledges that, to the best of his/her knowledge, all information provided in this report is accurate and complete. If there are any questions, comments, or concerns regarding the contents of this report, feel free to contact Inspector's Name at XXX-XXX-XXXX or email address.

Sketch Map



Legend:	 Area of Active Soil Disturbance	 Area has Achieved Temporary Stabilization
	 Area of Inactive Soil Disturbance	 Area has Achieved Final Stabilization



Inspection Photographs

1		2	

3		4	

5		6	

7		8	

9	10

11	12

Appendix J – Completed SWPPP Inspection Reports